

HI-303

Dual, SPDT CMOS Analog Switch

FN3125
Rev 1.00
Oct 1, 2015

The HI-303 switch is a monolithic device fabricated using CMOS technology and the Intersil dielectric isolation process. This switch features break-before-make switching, low and nearly constant ON resistance over the full analog signal range, and low power dissipation.

The HI-303 is TTL compatible and has a logic "0" condition with an input less than 0.8V and a logic "1" condition with an input greater than 4V. (See pinouts for switch conditions with a logic "1" input.)

Functional Diagram

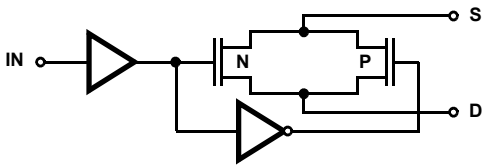

Pinout Switch States Shown For A Logic "1" Input

HI-303 (PDIP, CERDIP, SOIC)
TOP VIEW

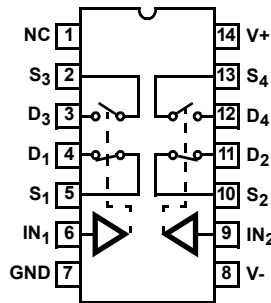

LOGIC	SW1, SW2	SW3, SW4
0	OFF	ON
1	ON	OFF

Features

- Analog Signal Range ($\pm 15V$ Supplies) $\pm 15V$
- Low Leakage at 25°C 40pA
- Low Leakage at 125°C 1nA
- Low On Resistance at 25°C 35Ω
- Break-Before-Make Delay 60ns
- Charge Injection 30pC
- TTL, CMOS Compatible
- Symmetrical Switch Elements
- Low Operating Power (Typ) 1.0mW
- Pb-Free Available (RoHS Compliant)

Applications

- Sample and Hold (i.e., Low Leakage Switching)
- Op Amp Gain Switching (i.e., Low On Resistance)
- Portable, Battery Operated Circuits
- Low Level Switching Circuits
- Dual or Single Supply Systems

Ordering Information

PART NUMBER	TEMP. RANGE (°C)	PACKAGE	PKG. DWG. #
HI1-0303-2	-55 to 125	14 Ld CERDIP	F14.3
HI3-0303-5Z (See Note)	0 to 75	14 Ld PDIP (Pb-free)	E14.3
HI9P0303-9Z (See Note)	-40 to 85	14 Ld SOIC (Pb-free)	M14.15

NOTE: Intersil Pb-free products employ special Pb-free material sets; molding compounds/die attach materials and 100% matte tin plate termination finish, which are RoHS compliant and compatible with both SnPb and Pb-free soldering operations. Intersil Pb-free products are MSL classified at Pb-free peak reflow temperatures that meet or exceed the Pb-free requirements of IPC/JEDEC J STD-020C.

Schematic Diagrams

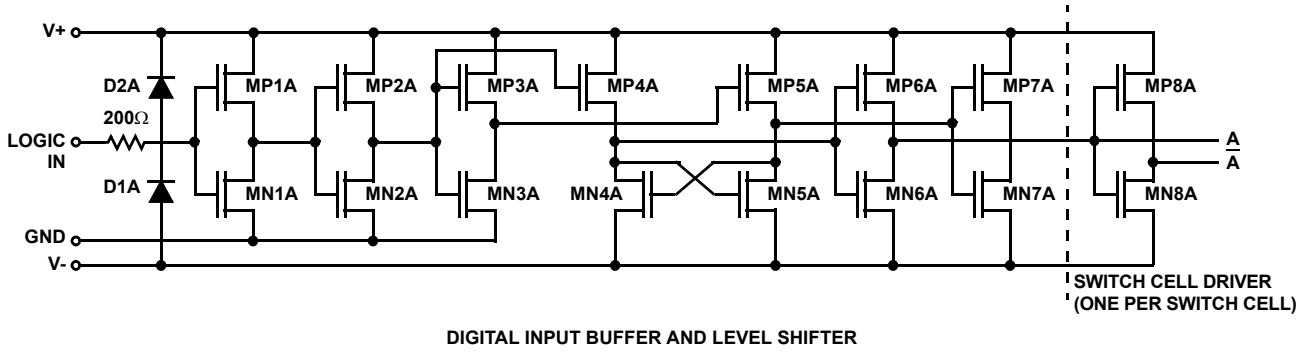
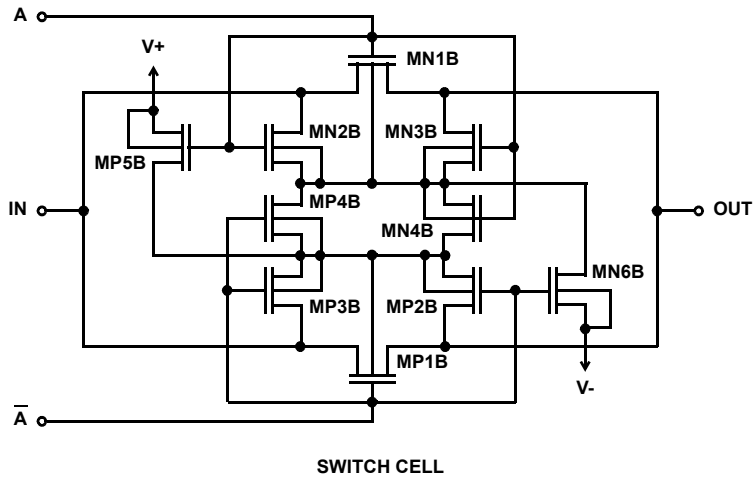

Absolute Maximum Ratings

Voltage Between Supplies (V+ to V-) 44V (±22V)
 Digital Input Voltage (V+) +4V to (V-) -4V
 Analog Input Voltage (V+) +1.5V to (V-) -1.5V
 Typical Derating Factor 1.5mA/MHz Increase in ICCOP
 ESD Classification Class 1

Operating Conditions

Temperature Range
 HI-303-2 -55°C to 125°C
 HI-303-5 0°C to 75°C
 HI-303-9 -40°C to 85°C

Thermal Information

Thermal Resistance (Typical, Note 1) θ_{JA} (°C/W) θ_{JC} (°C/W)
 CERDIP Package 80 24
 PDIP Package 90 N/A
 SOIC Package 120 N/A
 Maximum Junction Temperature
 Ceramic Packages 175°C
 Plastic Packages 150°C
 Maximum Storage Temperature Range -65°C to 150°C
 Maximum Lead Temperature (Soldering 10s) 300°C
 (SOIC - Lead Tips Only)

CAUTION: Stresses above those listed in "Absolute Maximum Ratings" may cause permanent damage to the device. This is a stress only rating and operation of the device at these or any other conditions above those indicated in the operational sections of this specification is not implied.

NOTE:

- θ_{JA} is measured with the component mounted on a low effective thermal conductivity test board in free air. See Tech Brief TB379 for details.

Electrical Specifications Supplies = +15V, -15V; V_{IN} = Logic Input. V_{IN} - for Logic "1" = 4V, for Logic "0" = 0.8V. Unless Otherwise Specified

PARAMETER	TEMP (°C)	-2			-5, -9			UNITS
		MIN	TYP	MAX	MIN	TYP	MAX	
DYNAMIC CHARACTERISTICS								
Switch ON Time, t_{ON}	25	-	210	300	-	210	300	ns
Switch OFF Time, t_{OFF}	25	-	160	250	-	160	250	ns
Break-Before-Make Delay, t_{OPEN}	25	-	60	-	-	60	-	ns
Charge Injection Voltage, ΔV (Note 7)	25	-	3	-	-	3	-	mV
OFF Isolation (Note 6)	25	-	60	-	-	60	-	dB
Input Switch Capacitance, $C_{S(OFF)}$	25	-	16	-	-	16	-	pF
Output Switch Capacitance, $C_{D(OFF)}$	25	-	14	-	-	14	-	pF
Output Switch Capacitance, $C_{D(ON)}$	25	-	35	-	-	35	-	pF
Digital Input Capacitance, C_{IN}	25	-	5	-	-	5	-	pF
DIGITAL INPUT CHARACTERISTICS								
Input Low Level, V_{INL}	Full	-	-	0.8	-	-	0.8	V
Input High Level, V_{INH} (Note 10)	Full	4	-	-	4	-	-	V
Input Leakage Current (Low), I_{INL} (Note 5)	Full	-	-	1	-	-	1	µA
Input Leakage Current (High), I_{INH} (Note 5)	Full	-	-	1	-	-	1	µA
ANALOG SWITCH CHARACTERISTICS								
Analog Signal Range	Full	-15	-	+15	-15	-	+15	V
ON Resistance, r_{ON} (Note 2)	25	-	35	50	-	35	50	Ω
	Full	-	40	75	-	40	75	Ω
OFF Input Leakage Current, $I_{S(OFF)}$ (Note 3)	25	-	0.04	1	-	0.04	5	nA
	Full	-	1	100	-	0.2	100	nA
OFF Output Leakage Current, $I_{D(OFF)}$ (Note 3)	25	-	0.04	1	-	0.04	5	nA
	Full	-	1	100	-	0.2	100	nA
ON Leakage Current, $I_{D(ON)}$ (Note 4)	25	-	0.03	1	-	0.03	5	nA
	Full	-	0.5	100	-	0.2	100	nA

Electrical Specifications Supplies = +15V, -15V; V_{IN} = Logic Input. V_{IN} - for Logic "1" = 4V, for Logic "0" = 0.8V. Unless Otherwise Specified **(Continued)**

PARAMETER	TEMP (°C)	-2			-5, -9			UNITS
		MIN	TYP	MAX	MIN	TYP	MAX	
POWER SUPPLY CHARACTERISTICS								
Current, I+ (Note 8)	25	-	0.09	0.5	-	0.09	0.5	mA
	Full	-	-	1	-	-	1	mA
Current, I- (Note 8)	25	-	0.01	10	-	0.01	100	μA
	Full	-	-	100	-	-	-	μA
Current, I+ (Note 9)	25	-	0.01	10	-	0.01	100	μA
	Full	-	-	100	-	-	-	μA
Current, I- (Note 9)	25	-	0.01	10	-	0.01	100	μA
	Full	-	-	100	-	-	-	μA

NOTES:

- $V_S = \pm 10V$, $I_{OUT} = \mp 10mA$. On resistance derived from the voltage measured across the switch under these conditions.
- $V_S = \pm 14V$, $V_D = \mp 14V$.
- $V_S = V_D = \pm 14V$.
- The digital inputs are diode protected MOS gates and typical leakages of 1nA or less can be expected.
- $V_S = 1V_{RMS}$, $f = 500kHz$, $C_L = 15pF$, $R_L = 1K$.
- $V_S = 0V$, $C_L = 10nF$, Logic Drive = 5V pulse. Switches are symmetrical; S and D may be interchanged. Charge Injection = $Q = C_L \times \Delta V$.
- $V_{IN} = 4V$ (one input, all other inputs = 0V).
- $V_{IN} = 0.8V$ (all inputs).
- To drive from DTL/TTL circuits, pullup resistors to +5V supply are recommended.

Test Circuits and Waveforms

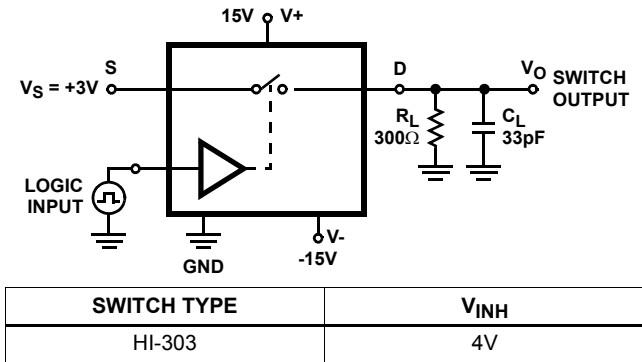

FIGURE 1A. TEST CIRCUIT

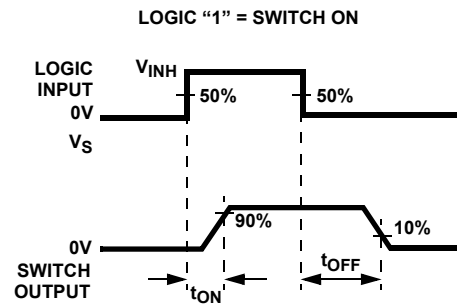

FIGURE 1B. MEASUREMENT POINTS

FIGURE 1. SWITCH t_{ON} AND t_{OFF}

Test Circuits and Waveforms (Continued)

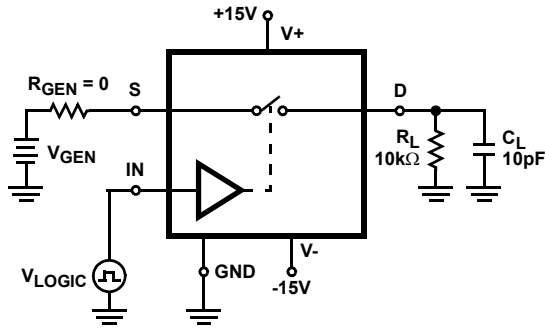

FIGURE 2A. TEST CIRCUIT

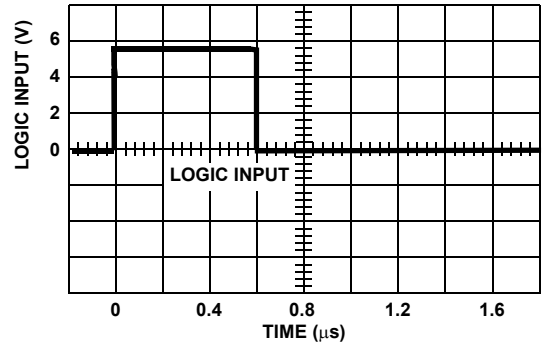

FIGURE 2B. TTL LOGIC INPUT

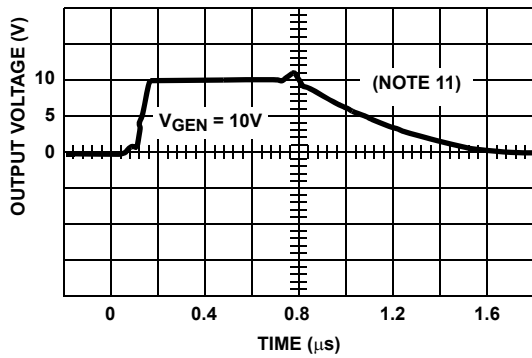

FIGURE 2C. $V_{ANALOG} = 10V$

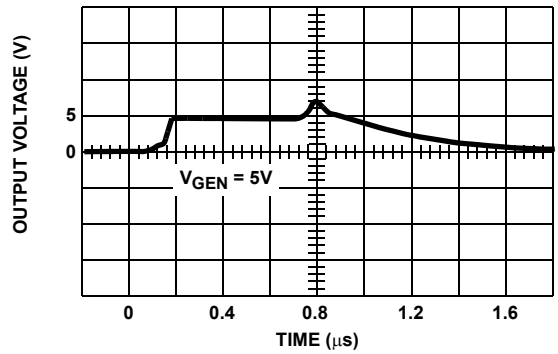

FIGURE 2D. $V_{ANALOG} = 5V$

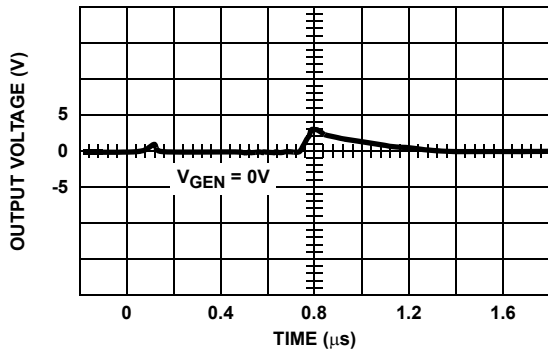

FIGURE 2E. $V_{ANALOG} = 0V$

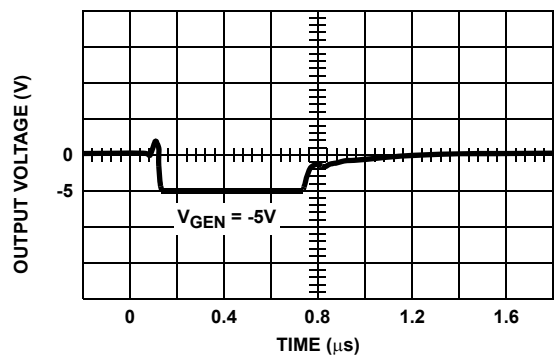

FIGURE 2F. $V_{ANALOG} = -5V$

Test Circuits and Waveforms (Continued)

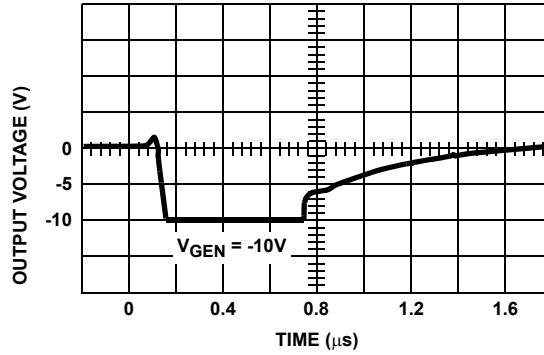

FIGURE 2G. $V_{ANALOG} = -10V$

NOTE:

11. If R_{GEN} , R_L or C_L is increased, there will be proportional increases in rise and/or fall RC times.

FIGURE 2. SWITCHING WAVEFORMS FOR VARIOUS ANALOG INPUT VOLTAGES

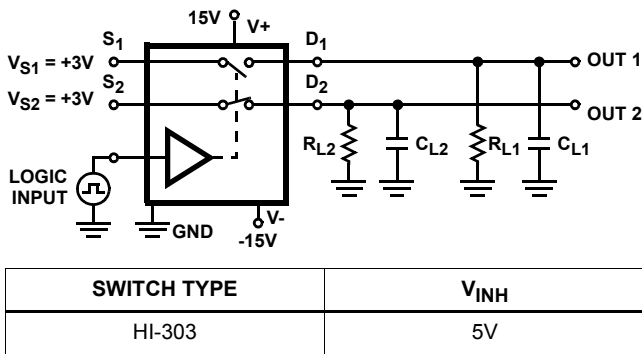

FIGURE 3A. TEST CIRCUIT

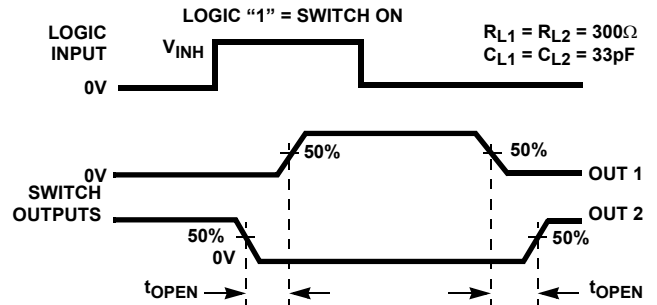

FIGURE 3B. MEASUREMENT POINTS

FIGURE 3. BREAK-BEFORE-MAKE DELAY (t_{OPEN})

Typical Performance Curves

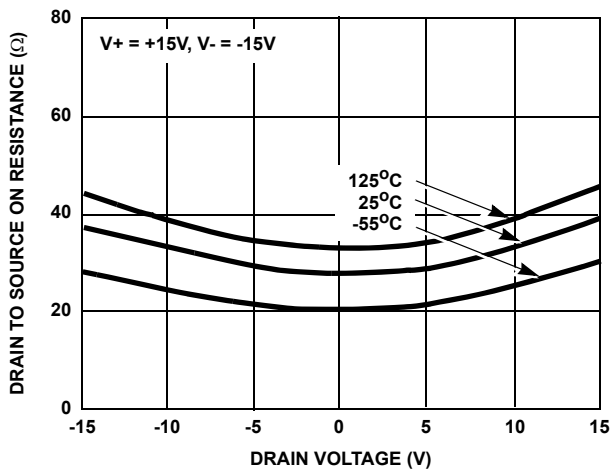

FIGURE 4. $r_{DS(ON)}$ vs V_D

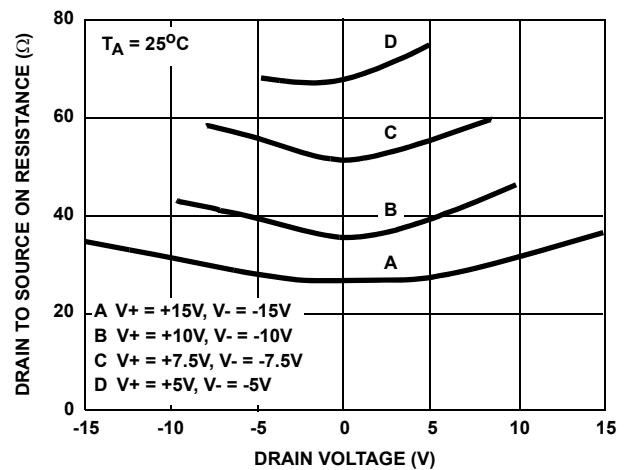

FIGURE 5. $r_{DS(ON)}$ vs V_D

Typical Performance Curves (Continued)

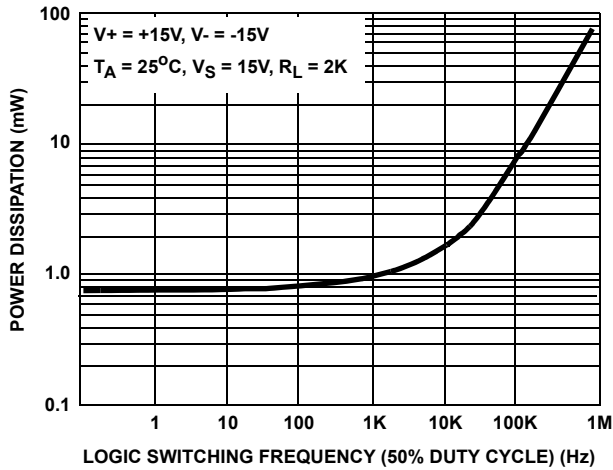

FIGURE 6. DEVICE POWER DISSIPATION vs SWITCHING FREQUENCY (SINGLE LOGIC INPUT)

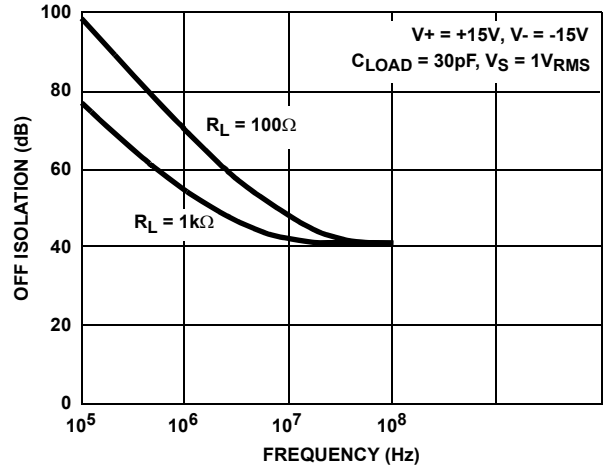

FIGURE 7. OFF ISOLATION vs FREQUENCY

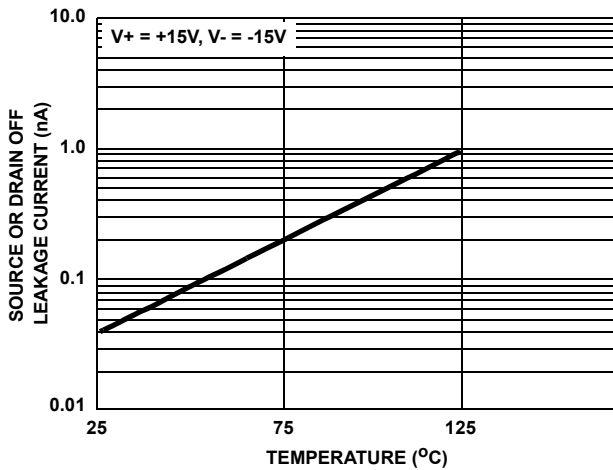

FIGURE 8. $I_{S(OFF)}$ OR $I_{D(OFF)}$ vs TEMPERATURE*

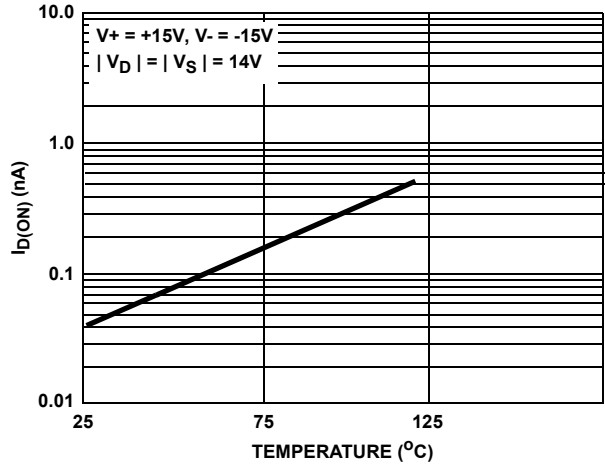

FIGURE 9. $I_{D(ON)}$ vs TEMPERATURE*

* The net leakage into the source or drain is the N-Channel leakage minus the P-Channel leakage. This difference can be positive, negative or zero depending on the analog voltage and temperature, and will vary greatly from unit to unit.

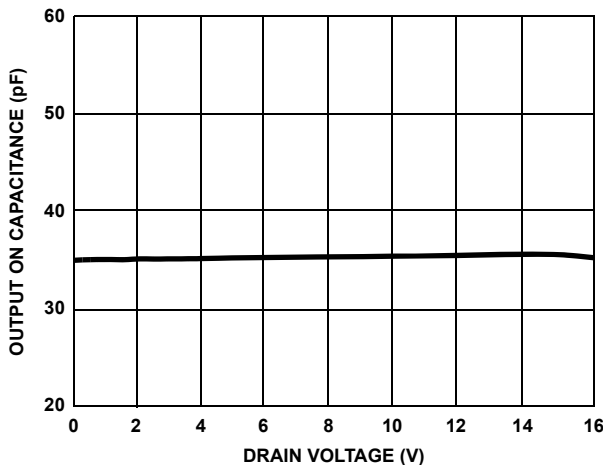

FIGURE 10. OUTPUT ON CAPACITANCE vs DRAIN VOLTAGE

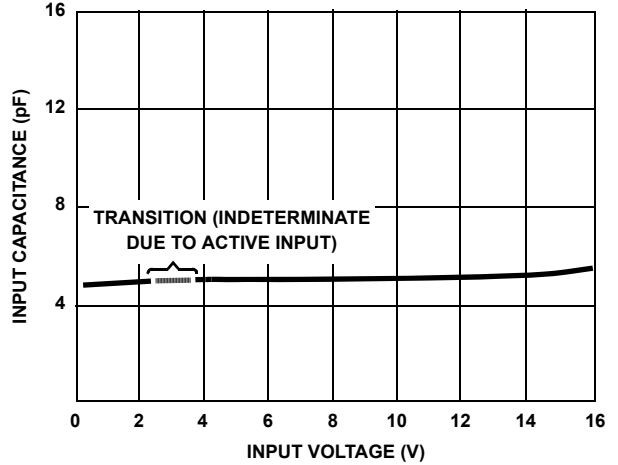

FIGURE 11. DIGITAL INPUT CAPACITANCE vs INPUT VOLTAGE

Typical Performance Curves (Continued)

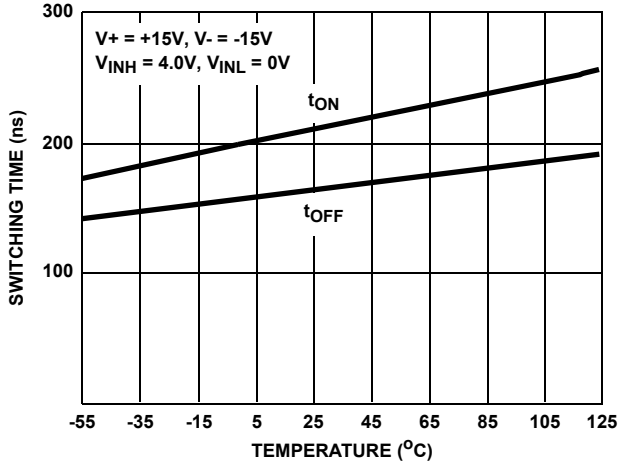

FIGURE 12. SWITCHING TIME vs TEMPERATURE

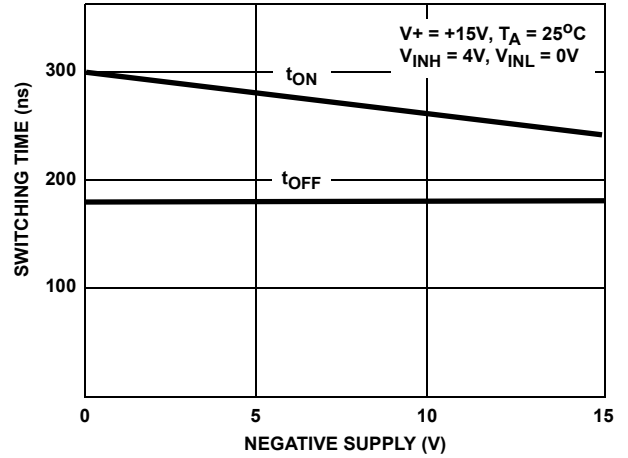

FIGURE 13. SWITCHING TIME vs NEGATIVE SUPPLY VOLTAGE

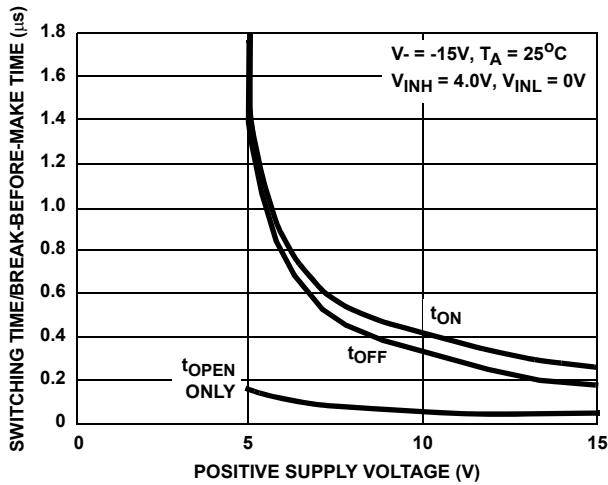

FIGURE 14. SWITCHING TIME AND BREAK-BEFORE-MAKE TIME vs POSITIVE SUPPLY VOLTAGE

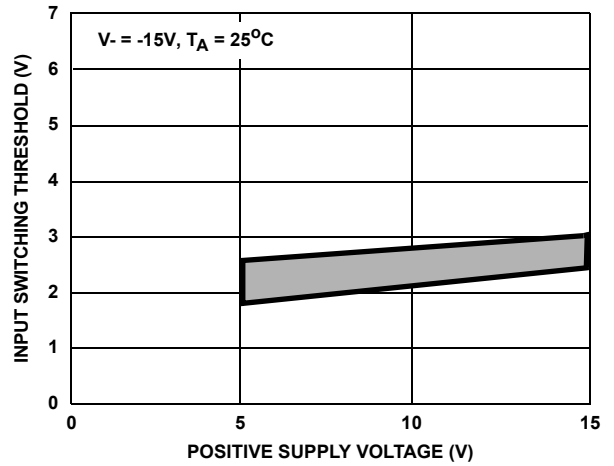

FIGURE 15. INPUT SWITCHING THRESHOLD vs POSITIVE SUPPLY VOLTAGE

Revision History

The revision history provided is for informational purposes only and is believed to be accurate, but not warranted. Please go to the web to make sure that you have the latest revision.

DATE	REVISION	CHANGE
October 1, 2015	FN3125.11	<ul style="list-style-type: none"> - Updated Ordering Information Table on page 1. - Added Revision History. - Added About Intersil Verbiage. - Updated POD M14.15 to latest revision changes are as follow: Added land pattern and moved dimensions from table onto drawing.

About Intersil

Intersil Corporation is a leading provider of innovative power management and precision analog solutions. The company's products address some of the largest markets within the industrial and infrastructure, mobile computing and high-end consumer markets.

For the most updated datasheet, application notes, related documentation and related parts, please see the respective product information page found at www.intersil.com.

You may report errors or suggestions for improving this datasheet by visiting www.intersil.com/ask.

Reliability reports are also available from our website at www.intersil.com/support.

© Copyright Intersil Americas LLC 2002-2015. All Rights Reserved.
 All trademarks and registered trademarks are the property of their respective owners.

For additional products, see www.intersil.com/en/products.html

Intersil products are manufactured, assembled and tested utilizing ISO9001 quality systems as noted in the quality certifications found at www.intersil.com/en/support/qualandreliability.html

Intersil products are sold by description only. Intersil may modify the circuit design and/or specifications of products at any time without notice, provided that such modification does not, in Intersil's sole judgment, affect the form, fit or function of the product. Accordingly, the reader is cautioned to verify that datasheets are current before placing orders. Information furnished by Intersil is believed to be accurate and reliable. However, no responsibility is assumed by Intersil or its subsidiaries for its use; nor for any infringements of patents or other rights of third parties which may result from its use. No license is granted by implication or otherwise under any patent or patent rights of Intersil or its subsidiaries.

For information regarding Intersil Corporation and its products, see www.intersil.com

Dual-In-Line Plastic Packages (PDIP)

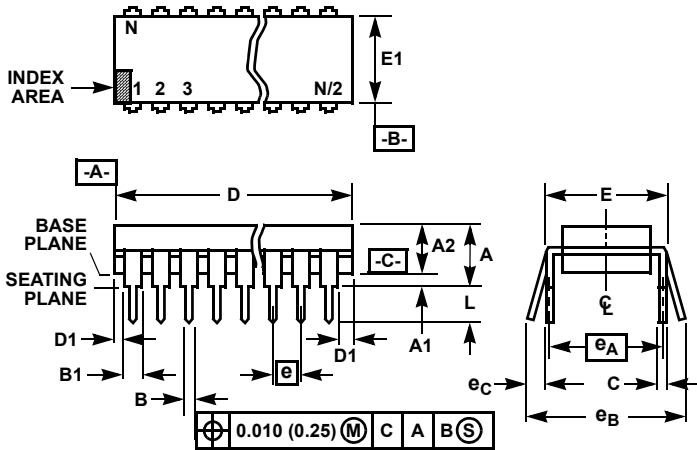

NOTES:

- Controlling Dimensions: INCH. In case of conflict between English and Metric dimensions, the inch dimensions control.
- Dimensioning and tolerancing per ANSI Y14.5M-1982.
- Symbols are defined in the "MO Series Symbol List" in Section 2.2 of Publication No. 95.
- Dimensions A, A1 and L are measured with the package seated in JEDEC seating plane gauge GS-3.
- D, D1, and E1 dimensions do not include mold flash or protrusions. Mold flash or protrusions shall not exceed 0.010 inch (0.25mm).
- E and e_A are measured with the leads constrained to be perpendicular to datum $-C-$.
- e_B and e_C are measured at the lead tips with the leads unconstrained. e_C must be zero or greater.
- B1 maximum dimensions do not include dambar protrusions. Dambar protrusions shall not exceed 0.010 inch (0.25mm).
- N is the maximum number of terminal positions.
- Corner leads (1, N, N/2 and N/2 + 1) for E8.3, E16.3, E18.3, E28.3, E42.6 will have a B1 dimension of 0.030 - 0.045 inch (0.76 - 1.14mm).

**E14.3 (JEDEC MS-001-AA ISSUE D)
14 LEAD DUAL-IN-LINE PLASTIC PACKAGE**

SYMBOL	INCHES		MILLIMETERS		NOTES
	MIN	MAX	MIN	MAX	
A	-	0.210	-	5.33	4
A1	0.015	-	0.39	-	4
A2	0.115	0.195	2.93	4.95	-
B	0.014	0.022	0.356	0.558	-
B1	0.045	0.070	1.15	1.77	8
C	0.008	0.014	0.204	0.355	-
D	0.735	0.775	18.66	19.68	5
D1	0.005	-	0.13	-	5
E	0.300	0.325	7.62	8.25	6
E1	0.240	0.280	6.10	7.11	5
e	0.100 BSC		2.54 BSC		-
e_A	0.300 BSC		7.62 BSC		6
e_B	-	0.430	-	10.92	7
L	0.115	0.150	2.93	3.81	4
N	14		14		9

Rev. 0 12/93

Ceramic Dual-In-Line Frit Seal Packages (CERDIP)

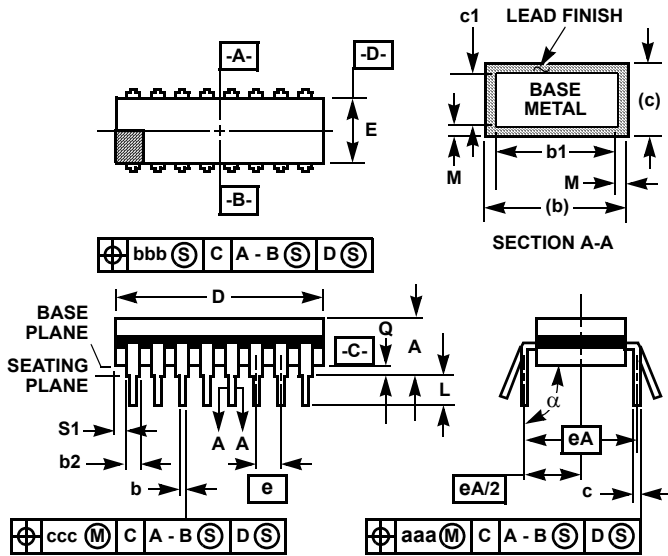

NOTES:

1. Index area: A notch or a pin one identification mark shall be located adjacent to pin one and shall be located within the shaded area shown. The manufacturer's identification shall not be used as a pin one identification mark.
2. The maximum limits of lead dimensions b and c or M shall be measured at the centroid of the finished lead surfaces, when solder dip or tin plate lead finish is applied.
3. Dimensions b1 and c1 apply to lead base metal only. Dimension M applies to lead plating and finish thickness.
4. Corner leads (1, N, N/2, and N/2+1) may be configured with a partial lead paddle. For this configuration dimension b3 replaces dimension b2.
5. This dimension allows for off-center lid, meniscus, and glass overrun.
6. Dimension Q shall be measured from the seating plane to the base plane.
7. Measure dimension S1 at all four corners.
8. N is the maximum number of terminal positions.
9. Dimensioning and tolerancing per ANSI Y14.5M - 1982.
10. Controlling dimension: INCH.

**F14.3 MIL-STD-1835 GDIP1-T14 (D-1, CONFIGURATION A)
14 LEAD CERAMIC DUAL-IN-LINE FRIT SEAL PACKAGE**

SYMBOL	INCHES		MILLIMETERS		NOTES
	MIN	MAX	MIN	MAX	
A	-	0.200	-	5.08	-
b	0.014	0.026	0.36	0.66	2
b1	0.014	0.023	0.36	0.58	3
b2	0.045	0.065	1.14	1.65	-
b3	0.023	0.045	0.58	1.14	4
c	0.008	0.018	0.20	0.46	2
c1	0.008	0.015	0.20	0.38	3
D	-	0.785	-	19.94	5
E	0.220	0.310	5.59	7.87	5
e	0.100 BSC		2.54 BSC		-
eA	0.300 BSC		7.62 BSC		-
eA/2	0.150 BSC		3.81 BSC		-
L	0.125	0.200	3.18	5.08	-
Q	0.015	0.060	0.38	1.52	6
S1	0.005	-	0.13	-	7
α	90°	105°	90°	105°	-
aaa	-	0.015	-	0.38	-
bbb	-	0.030	-	0.76	-
ccc	-	0.010	-	0.25	-
M	-	0.0015	-	0.038	2, 3
N	14		14		8

Rev. 0 4/94

Package Outline Drawing

M14.15

14 LEAD NARROW BODY SMALL OUTLINE PLASTIC PACKAGE

Rev 1, 10/09

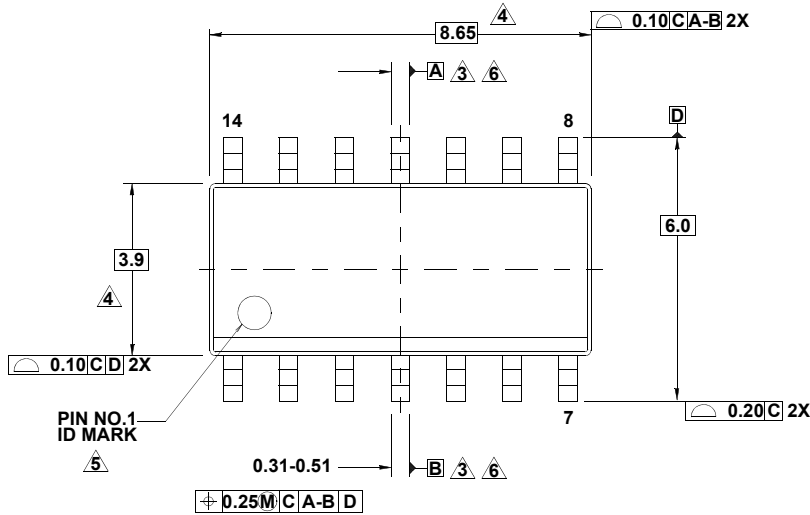

TOP VIEW

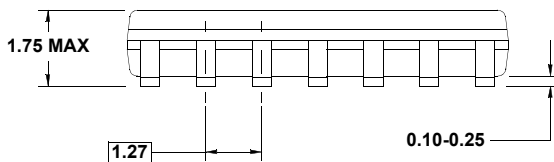
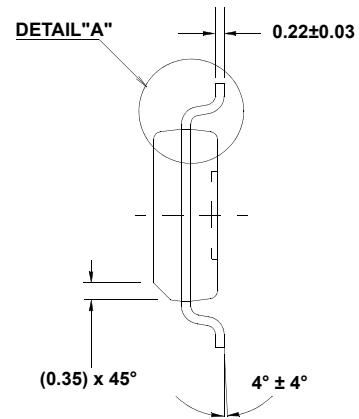

SIDE VIEW

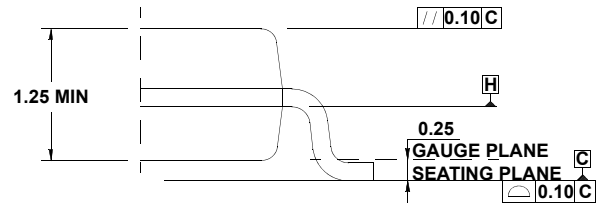

DETAIL "A"

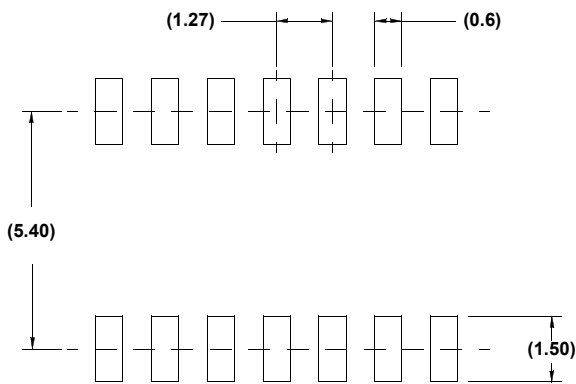

TYPICAL RECOMMENDED LAND PATTERN

NOTES:

1. Dimensions are in millimeters.
Dimensions in () for Reference Only.
2. Dimensioning and tolerancing conform to AMSEY14.5m-1994.
3. Datums A and B to be determined at Datum H.
4. Dimension does not include interlead flash or protrusions.
Interlead flash or protrusions shall not exceed 0.25mm per side.
5. The pin #1 identifier may be either a mold or mark feature.
6. Does not include dambar protrusion. Allowable dambar protrusion shall be 0.10mm total in excess of lead width at maximum condition.
7. Reference to JEDEC MS-012-AB.