

REVISIONS				
REV.	EAR	DESCRIPTION	DATE	APPROVED
B	13741	NOTE UPDATES	JUL06/10	K.L

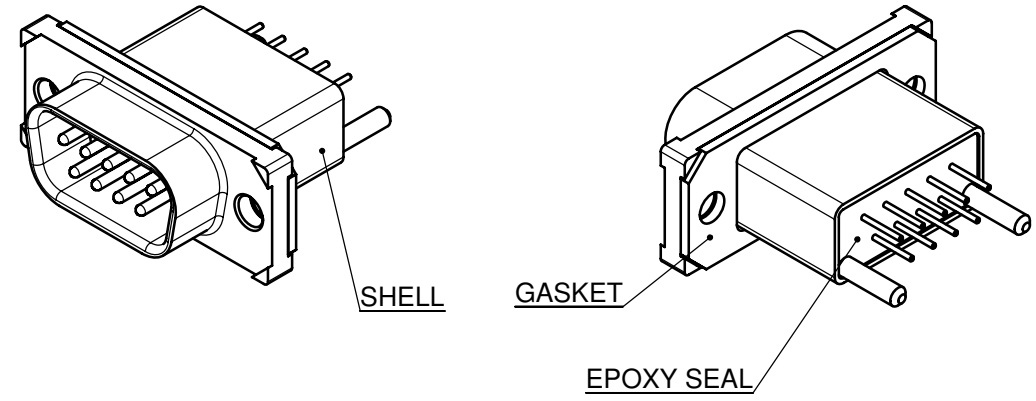

MDB-E09PE-765 IS SHOWN

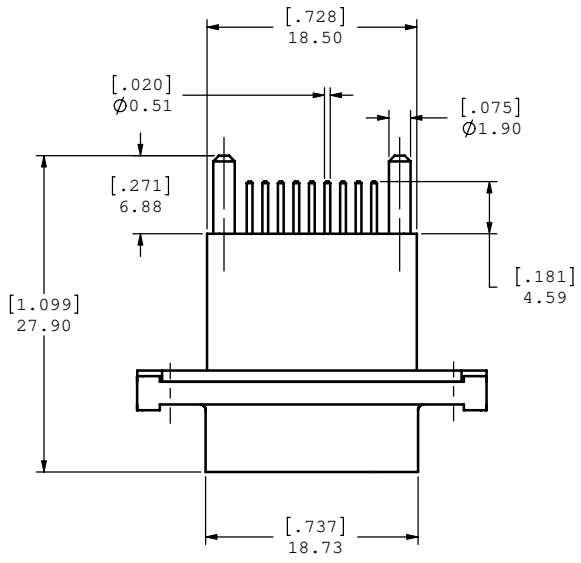
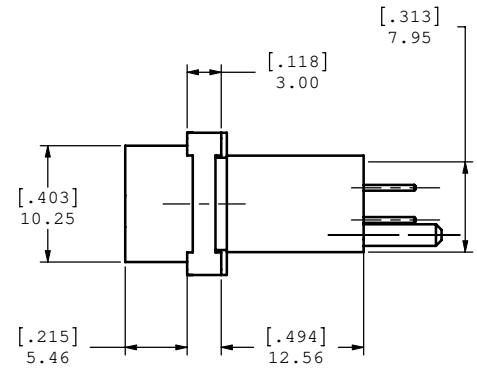
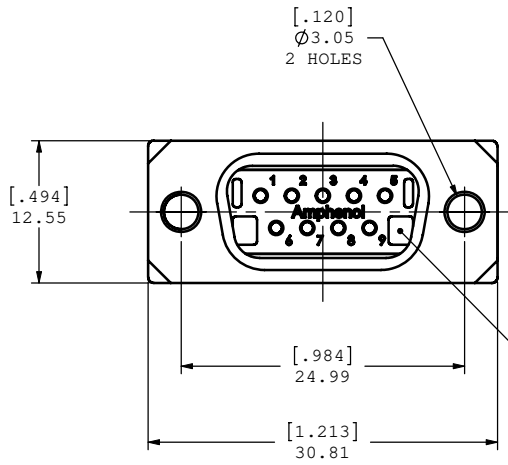

HOUSING

NOTES:

- MATERIAL:**
 - SHELL: ZINC ALLOY WITH 50 MICRO INCH MINIMUM NICKEL PLATING,
 - CONTACTS: COPPER ALLOY 30 MICRO INCH GOLD OVER 50 MICRO INCH NICKEL PLATING,
 - HOUSING: THERMOPLASTIC RESIN, UL94V-0
 - GASKET: SILICONE RUBBER,
 - SCREWS: STAINLESS STEEL,
 - DUST COVER: SILICONE RUBBER.
- FEATURES:** SEALED CONNECTOR IN THE MATED AND UNMATED CONDITIONS.
- OPERATING TEMPERATURE:** -40°C TO +105°C.
- ENVIRONMENT PERFORMANCE:** IP67.
- CONNECTOR IS RoHS COMPLIANT PER EU DIRECTIVE 2002/95/EC AND AMENDMENTS.**
- PART NUMBER FOR ORDER:**
 - MDB-E09PE-760 - WITH DUST COVER AND SCREWS.(SEE PAGE 2 FOR MORE INFORMATION)
 - MDB-E09PE-765 - NO DUST COVER AND SCREWS.



UNLESS OTHERWISE SPECIFIED DIMENSIONS ARE IN MILLIMETER TOLERANCES ARE: DECIMALS .XX ±.10 .X ±.25 ANGLES ±1°		APPROVALS	DATE	Amphenol Canada Corp.	
MATERIAL AND FINISH		DRAWN S.SEMENOV	OCT06/06		
REF.		DESIGNED S.SEMENOV	OCT06/06	TITLE RUGGED 9 PIN, D-SUB CONNECTOR, VERTICAL MOUNT	
CODE IDENT. NO.		CHECKED		SIZE C	DWG. NO. P-MDB-E09PE-76X
		QA APP'D		SCALE 3:1	PROJECT MDB
		IE APP'D			REV. B
		DWG APP'D A.GREEN	OCT06/06		SHEET 1 OF 2

DO NOT SCALE DRAWING
THIS DOCUMENT CONTAINS PROPRIETARY INFORMATION AND SUCH INFORMATION MAY NOT BE DISCLOSED TO OTHERS FOR ANY PURPOSE OR USED FOR MANUFACTURING PURPOSES WITHOUT PERMISSION FROM AMPHENOL CANADA CORP.

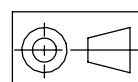

REVISIONS				
REV.	EAR	DESCRIPTION	DATE	APPROVED
B	13741	NOTE UPDATES	JUL06/10	K.L

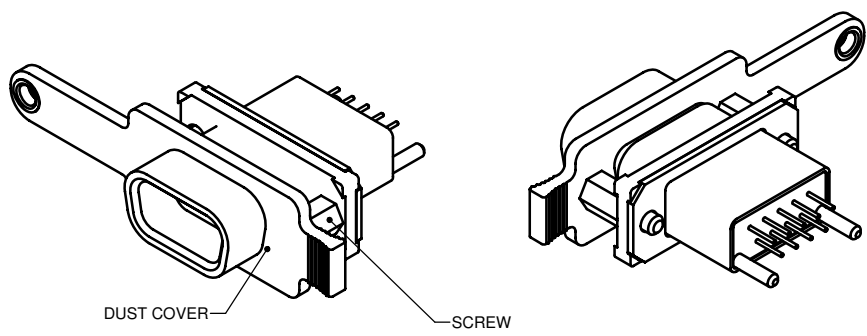
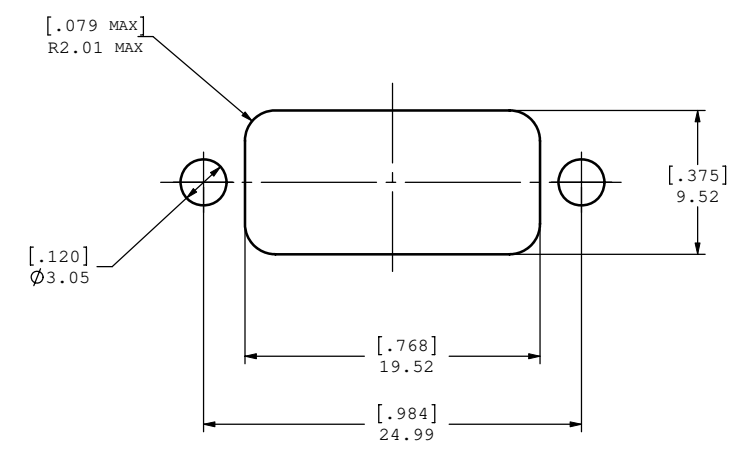
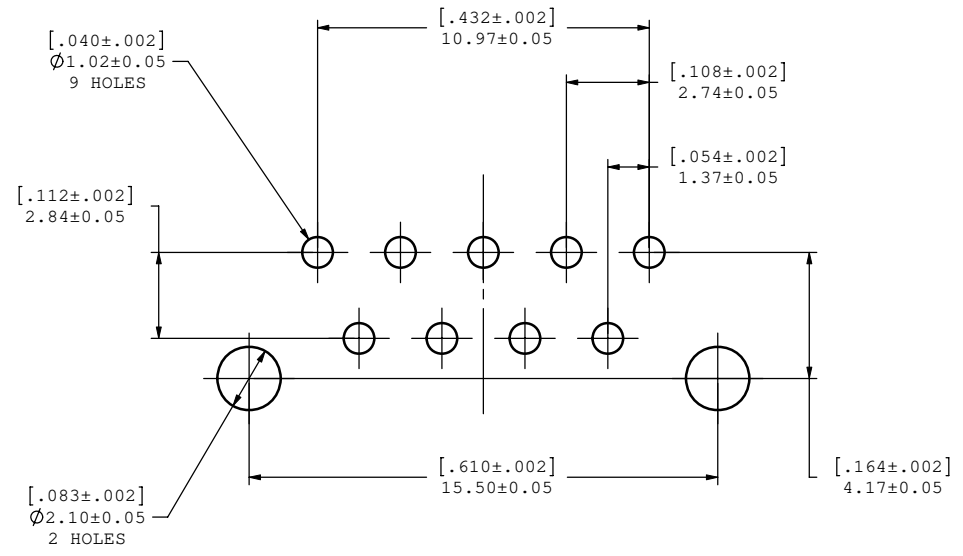

MDB-E09PE-760 IS SHOWN
FOR MORE INFORMATION ABOUT DUST COVER,
SEE DRAWING P-MDB-227-093-205BP



UNLESS OTHERWISE SPECIFIED DIMENSIONS ARE IN MILLIMETER TOLERANCES ARE:		APPROVALS	DATE	Amphenol Canada Corp.	
DECIMALS	ANGLES	DRAWN	OCT06/06		
.XX ±.10	± 1°	S.SEMENOV		TITLE RUGGED 9 PIN, D-SUB CONNECTOR, VERTICAL MOUNT	
.X ±.25		DESIGNED	OCT06/06		
MATERIAL AND FINISH		CHECKED		SIZE	DWG. NO.
REF.		QA APP'D		C	P-MDB-E09PE-76X
CODE IDENT. NO.		IE APP'D		SCALE	PROJECT
		DWG APP'D	OCT06/06	3:1	MDB
		A.GREEN			SHEET
					2 OF 2

DO NOT SCALE DRAWING
 THIS DOCUMENT CONTAINS PROPRIETARY INFORMATION AND SUCH INFORMATION MAY NOT BE DISCLOSED TO OTHERS FOR ANY PURPOSE OR USED FOR MANUFACTURING PURPOSES WITHOUT PERMISSION FROM AMPHENOL CANADA CORP.