

# PRM-AL Customer Evaluation Boards



Contents	Page
<a href="#">Introduction</a>	<a href="#">1</a>
<a href="#">Board Overview</a>	<a href="#">2</a>
<a href="#">Recommended Hardware</a>	<a href="#">4</a>
<a href="#">Kit #26647 Contains:</a>	<a href="#">4</a>
<a href="#">Initial Set Up</a>	<a href="#">4</a>
<a href="#">Baseline Test Procedure</a>	<a href="#">4</a>
<a href="#">VTM Evaluation Board</a>	<a href="#">8</a>
<a href="#">The DC-DC Converter Chipset</a>	<a href="#">9</a>
<a href="#">Ordering Information</a>	<a href="#">9</a>

## Introduction

A Factorized Power Architecture™ offers a fundamentally new and improved approach to distributed power. Factorizing DC-DC power conversion into its basic functions – isolation and transformation on the one hand and output voltage control and regulation on the other – and arranging those functions in a sequence maximizes power system performance and cost effectiveness. VTM™ modules put isolated current multiplication and voltage division directly at the point-of-load (PoL), and an upstream PRM™ non-isolated regulator controls the Factorized Bus voltage supplied to the VTM to provide line and load regulation. With this architecture, the Factorized Bus voltage can be relatively high; distribution losses can be minimized with narrower copper traces; and the PRM may be located at any convenient location, either adjacent to or remote from the VTM. PRMs operate from a wide variety of input sources to drive VTMs. VTMs are extremely fast and quiet and provide voltage division ratios as high as 32. VTMs enable the user to efficiently supply up to 100A from each full VI Chip® package at regulated output voltages as low as  $0.8V_{DC}$  or higher, as needed.

With FPAT™, only a VTM is needed at the PoL. VTMs, unimpeded by serial inductance, feature very high bandwidth and extremely fast transient response, allowing energy to be stored efficiently at the relatively high Factorized Bus voltage. Without bulk capacitors at the PoL, precious board real estate may be reclaimed for essential functions. The density, efficiency, performance, cost-effectiveness and architectural superiority of FPA make it the least intrusive form of distributed power and facilitate the development of more advanced, competitive products.

The PRM may be used as a standalone non-isolated regulation stage, whereas the VTM is intended to be used with a PRM.



### IMPORTANT NOTICE:

Be sure to read this design guide manual thoroughly before using this product. Pay attention to all cautions and warnings.

The Customer Evaluation Boards described in this document are intended to acquaint you with the benefits and features of a Factorized Power Architecture (FPA). They are not designed to be installed in end-use equipment.

During operation, the power devices and surrounding structures can be operated safely at high temperatures.

The list below is not comprehensive and is not a substitute for common sense and good practice.

- Remove power and use caution when connecting and disconnecting test probes and interface lines to avoid inadvertent short circuits and contact with hot surfaces.
- When testing electronic products always use approved safety glasses. Follow good laboratory practice and procedures.

## Board Overview

Please take a closer look at the PRM-CB board. Figure 1 is a picture of a PRM-AL mounted to the PRM-CB board. The board has several features that enable the user to fully explore the capabilities of the PRM-AL.

**Figure 1**  
PRM-AL mounted to  
PRM-CB board

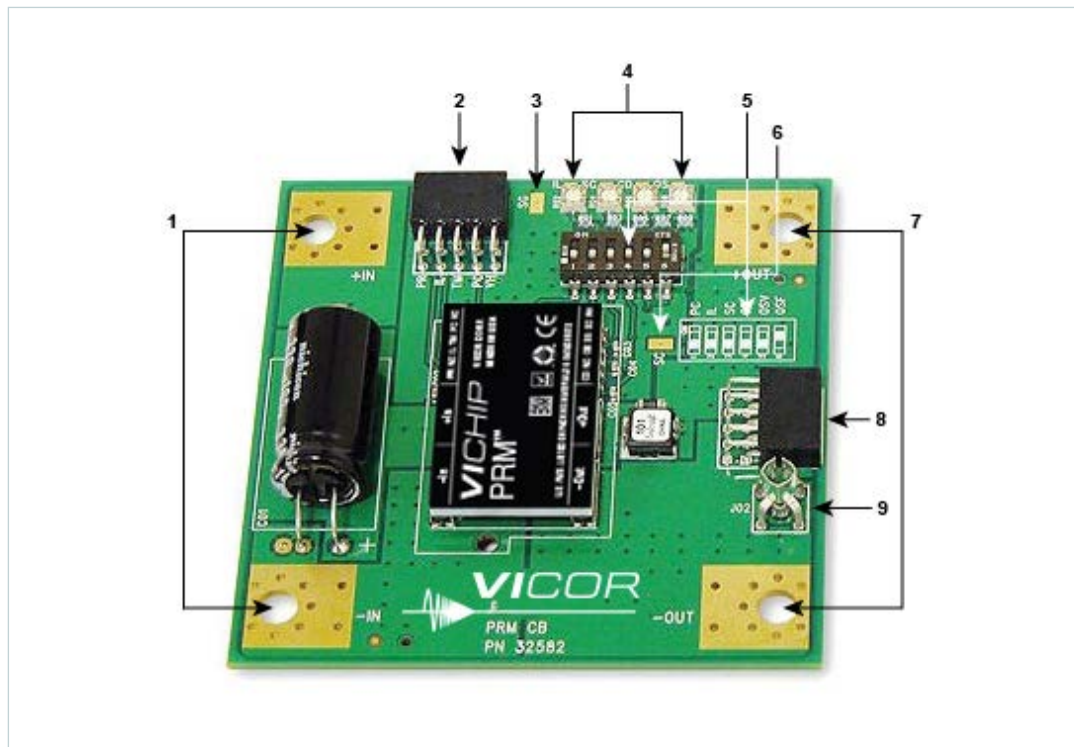

1. Source voltage input points are designed to accommodate #10 hardware and Panduit ring lugs. **BE CERTAIN THAT THE POLARITY IS CORRECT BEFORE APPLYING POWER.**
2. Auxiliary control (H01) – access points for PR, IL, TM, PC, and VH, (header shown installed).
3. Reference test point Signal Ground (SG).
4. Adjustment potentiometers for indicated function are used in conjunction with actuation of corresponding switch in Item 5.
5. PRM™ port connections (switch bank and silk-screen reference).
  - a. Toggling the switch indicated PC to the ON position inhibits the PRM output.
  - b. Toggling the switch indicated IL to the ON position enables an adjustable current limit effected by varying the corresponding IL trim pot (Item 4).
  - c. Toggling the switch indicated SC to the ON position enables adjustment of the output voltage down from the set point determined by the OS resistor by varying the corresponding SC trim pot (Item 4).  
**CAUTION:** depending upon the initial output voltage set point determined by the OS resistor it is possible to trim the SC so low that the output shuts off. The minimum output voltage per the data sheet is  $26V_{DC}$ .
  - d. Toggling the switch indicated CD to the ON position places the PRM in Adaptive-Loop regulation mode (for use with the VTM-CB) from the Local-Loop regulation mode. (In Local Loop mode the set voltage is regulated at the output terminals of the PRM.) Adjusting the corresponding CD trim pot (Item 4) changes the gain of the loop to compensate for different OS settings and/or interconnect resistive losses.

- e. Toggling the switch indicated OSV (OS Variable) to the ON position requires the switch indicated OSF (OS Fixed) be placed in the OFF position and allows the PRM™ output set point to be varied within the range specified on the data sheet.
  - f. Toggling the switch indicated OSF to the ON position sets the output of the PRM to the nominal value indicated on the data sheet. If this switch is in the OFF position and the OSV switch is also OFF, the unit will not function.
  - g. IT IS BEST TO SET THE SWITCH POSITION AND CORRESPONDING TRIM POT SETTINGS BEFORE APPLYING POWER TO THE BOARD.**
6. Test point for Secondary Control (SC).
  7. Output voltage points are designed to accommodate #10 hardware and Panduit ring lugs.
  8. Output connector (J01) for mating with VTM-CB providing  $V_{OUT}$  and VC. As shown on the schematic (Figure 2) there are four pins dedicated to the +OUT, four for the -OUT, and two for the VC. Each contact is rated for 3A. The excess capacity afforded by these pins can facilitate testing multiple VTM-CBs from a single PRM-CB using an appropriate wiring harness and mating connector. This may also be achieved using the large pads of Item 7.
  9. Output scope jack (J02). Headers H01 and J01 are 0.100in spacing, 10 position female, manufactured by Sullins Electronics and available from Digi-Key as part # S5519-ND.

**Figure 2**  
PRM-CB  
schematic diagram

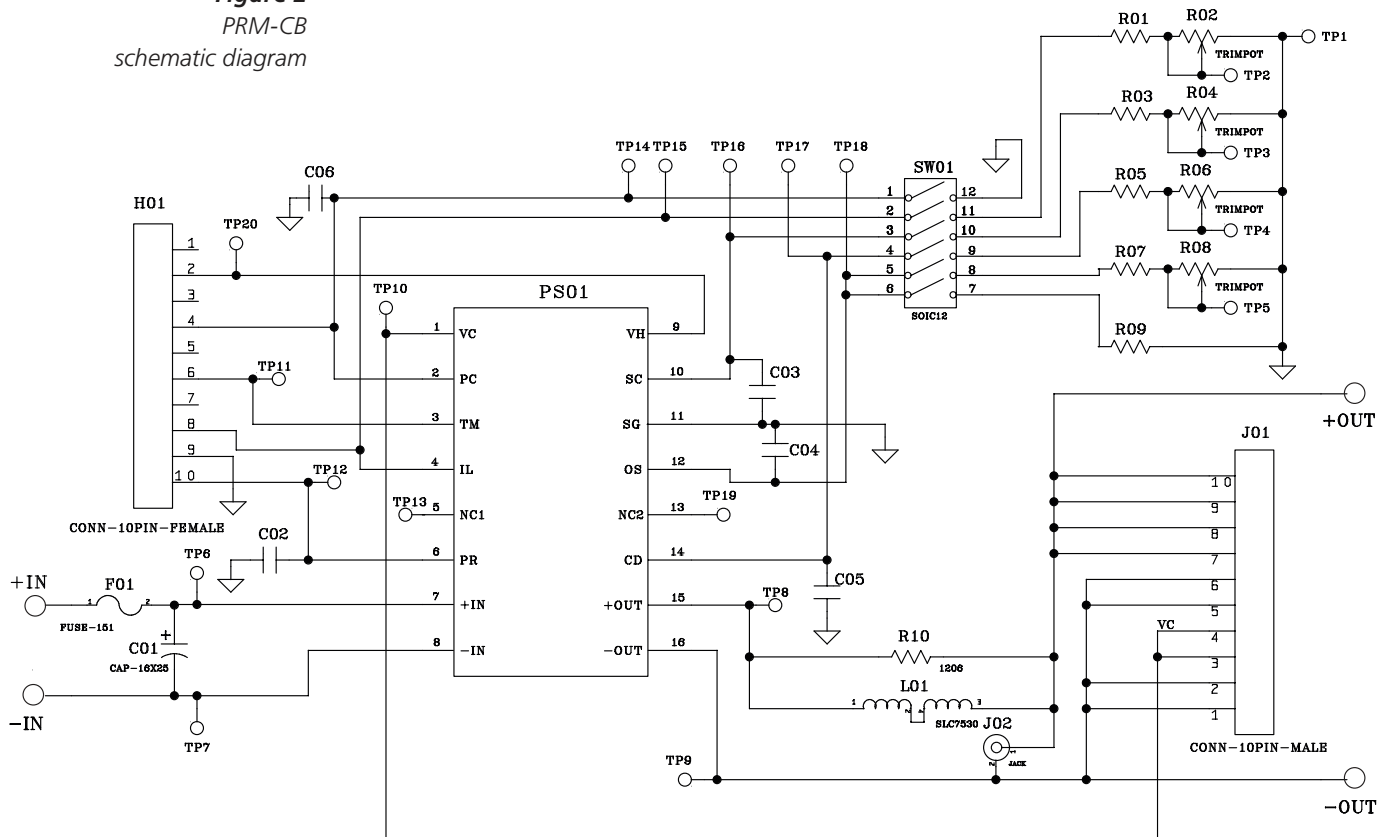

**NOTES:**

1. ALL CAPACITORS SIZE 0603 UNLESS OTHERWISE SPECIFIED.
2. ALL RESISTORS SIZE 0603 UNLESS OTHERWISE SPECIFIED.

## Recommended Hardware

Qty	Description	Manufacturer P/N
4	Ring lug	Panduit LCAS6-10-L

## Kit #26647 Contains:

Qty	Description
4	#10-32 screw
4	#10 flat washer
4	#10 lock washer
4	#10 hex nut

All hardware is stainless steel except the ring lug.  
Kit #26647 is included with the Customer Evaluation Board.

## Initial Set Up

To test the PRM™ mounted to the board it is necessary to configure the switch bank (Item 5) as shown on the silk screen in Figure 3. Placing the switch bank in this state connects a fixed resistor between OS and SG of the PRM that sets the output voltage of the PRM to the nominal value indicated on its respective data sheet.

Failure to configure the switch bank in this state prior to testing may result in improper output or no output.

## Baseline Test Procedure – PRM-CB (Refer to Figure 3)

### 1.0 Recommended Equipment

- 1.1 DC power supply: 0 – 100V; 500W
- 1.2 DC electronic load: pulse capable; 0 – 100V; 100A minimum
- 1.3 DMM
- 1.4 Oscilloscope
- 1.5 Appropriately-sized interconnect cables
- 1.6 Fastening hardware
- 1.7 Fan (if the PRM is to be operated for extended periods of time or at an elevated ambient temperature we recommend the supplied heat sink be installed)
- 1.8 Safety glasses
- 1.9 Data sheet for the requisite PRM

**Figure 3**  
PRM™ customer board layout

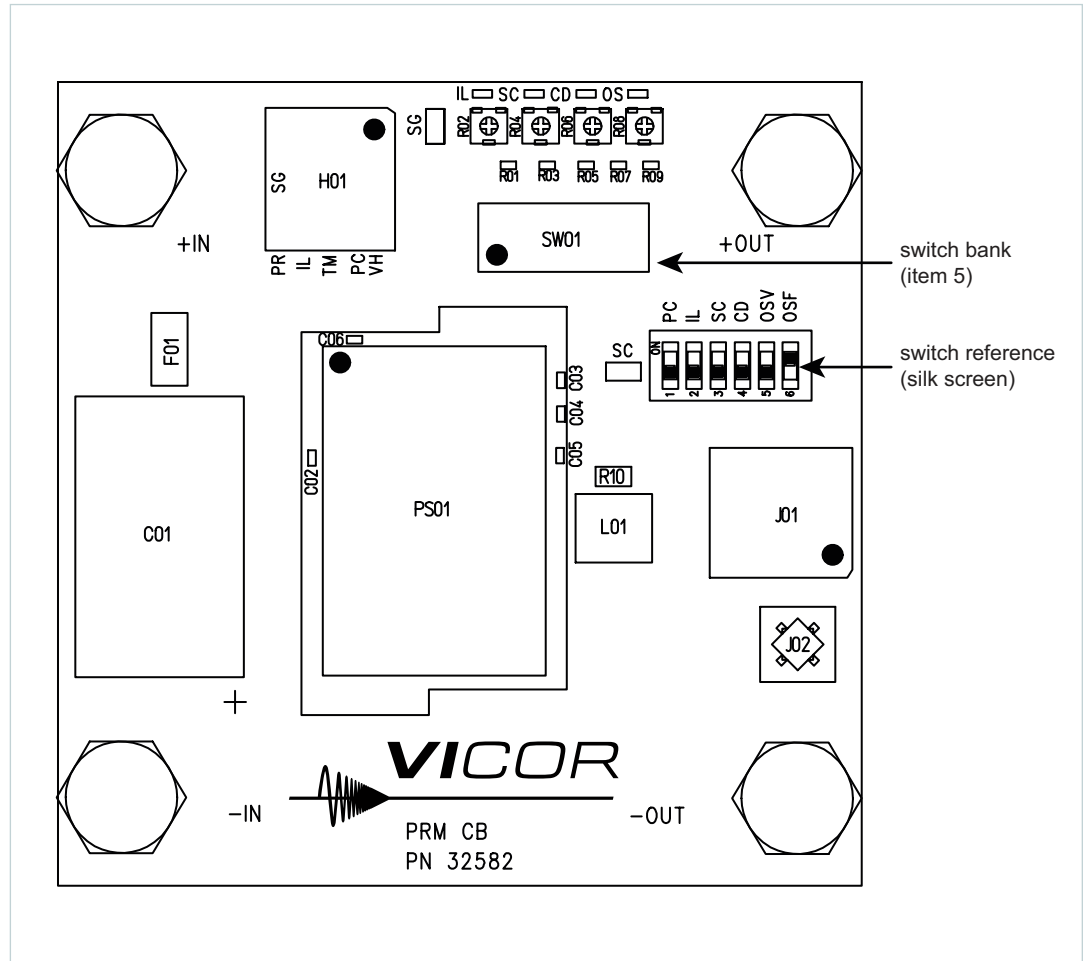

## 2.0 Hook Up

- 2.1 Connect the power supply +OUT lead to the +IN terminal of the Customer Evaluation Board.
- 2.2 Connect the power supply -OUT lead to the -IN terminal of the Customer Evaluation Board.
- 2.3 A high-quality, low-noise power supply should be connected to these locations.
- 2.4 Connect a lead between the +OUT of the Customer Evaluation Board and +IN of the load.
- 2.5 Connect a lead between the -OUT of the Customer Evaluation Board and -IN of the load.
- 2.6 Connections to these locations should be with short heavy-gauge leads.

## 3.0 Verify Connections

---

#### 4.0 Test Sequence

- 4.1 Have the latest version of the PRM™ data sheet in hand.
- 4.2 Assure that the DC supply is set to  $0V_{DC}$  prior to turning the unit on.
- 4.3 Confirm that the switch bank is configured as shown in the silk screen on the board.
- 4.4 Turn on the DC supply.
- 4.5 Make sure the DC load is set to constant current and at 0A prior to turning on the load.
- 4.6 Turn on the DC load.
- 4.7 Connect an oscilloscope to the test point provided to monitor output voltage. Many types of scope probes may be directly connected to these points if the probe is equipped with a removable plastic sheath. Be careful to avoid creating ground loops when making measurements of this voltage and the input voltage. It is recommended that the measurements be made separately. Shorting the –input and –output of the PRM will defeat the PRM current limit feature as the current shunt is in this path.
- 4.8 Turn on a fan if desired.
- 4.9 Raise the DC input voltage to the nominal value indicated on the data sheet.
- 4.10 Verify no-load operation by raising and lowering the input voltage through the entire input voltage range. The output voltage should remain constant within the tolerance indicated in the data sheet.
- 4.11 Re-establish the nominal input voltage.
- 4.12 Slowly increase the load current to full load while monitoring the output voltage. The output voltage should remain within the limits specified in the appropriate PRM data sheet.
- 4.13 Return the load current to 0A and decrease the input voltage to low line.
- 4.14 Repeat step 4.12. Depending upon the supply used and the source impedance it may be necessary to adjust the input voltage to keep the input to the PRM at low line.
- 4.15 Return the load current to 0A and increase the input voltage to high line.
- 4.16 Repeat step 4.12.

#### 5.0 You have now verified the functionality of the PRM over the entire line and load operating range.

#### 6.0 Deviating from Nominal Settings

This board has provisions, as described in the Board Overview section, to adjust the configuration of the PRM about the nominal values. The data sheet for the PRM has equations and curves for determining the required resistor values needed for specific conditions.

Applications requiring output voltages other than the nominal setting will need to have the new value set via the trim pots and respective switches. Reference Items 4 and 5 of the Board Overview and the schematic shown in Figure 2.

---

## 6.1 Adjust the PRM™ Output Voltage Set Point

- 6.1.1 Make sure that the power is removed from the unit prior to making adjustment.
- 6.1.2 Using a DMM (set to measure resistance), probe between SG (Item 3) and the pad labeled OS located next to the 5kΩ trim pot R08.
- 6.1.3 Adjust R08 such that the meter reads ~200Ω. This value added to the fixed resistor R07 should total ~2.3kΩ. Note: R07 is 1.7kΩ on the boards with the MIL-COTS PRM.
- 6.1.4 One could also probe between SG and the ON side of switch OSV (#5) and set the total resistance shown to ~2.3kΩ.
- 6.1.5 Move switch OSF (#6) to the OFF position.
- 6.1.6 Move switch OSV (#5) to the ON position.
- 6.1.7 The unit is now ready to provide the desired output voltage set point.
- 6.1.8 Powering the device on should yield a no-load output voltage of the nominal specified value.
- 6.1.9 The output voltage can now be set to the desired value by varying trim pot OS (R08).
- 6.1.10 **IT MAY BE POSSIBLE TO INADVERTENTLY TRIM THE OUTPUT TOO HIGH ENABLING THE OVERVOLTAGE PROTECTION CIRCUIT.**  
If this happens, reduce the impedance of R08. The initial conditions of steps 6.1.2 and 6.1.3 can be used to recover.
- 6.1.11 The desired output voltage set point can also be achieved by using the equations in the data sheet and setting the total OS resistance (R07 + R08) to that value and then configuring the switches as above.
- 6.1.12 Be certain to adhere to the power vs. output voltage curve in the data sheet to avoid over powering the device!

## 6.2 Adjusting the Current Limit

- 6.2.1 Increasing the load beyond the rated maximum may activate the PRM's internal current limit (see data sheet for values) feature. Certain applications may require a lower limit and for those situations we offer the adjustment feature.
- 6.2.2 Refer to the data sheet for the resistance vs. limit curve for the desired limit value. Note: the IL values of resistors installed on this board (R01 + R02: 2kΩ + 100kΩ) may not cover the entire range of the curve.
- 6.2.3 The adjustable IL mode is engaged by repositioning the IL switch (#2) from OFF to ON. (This may be done while the unit is powered.)
- 6.2.4 Adjusting the IL trim pot will reduce the current limit from the factory pre-set limits specified in the data sheet. It is not possible to increase this limit beyond the factory settings.
- 6.2.5 To reinstate the factory limit return the IL switch to the OFF position.

### 6.3 Trimming the output voltage using SC

- 6.3.1 Once the output voltage has been determined and set using the OS resistors, it is still possible to trim the output down to 26V using the SC control. Adjusting the output in this manner rather than merely adjusting the output via the OS values provides improved regulation.
- 6.3.2 Depending upon the chosen initial output voltage determined by the OS resistors, the amount of available adjustment might be very limited. Enabling SC adjustment by toggling the SC switch (#3) to the ON position may result in shut down.
- 6.3.3 To avoid the situation described in 6.3.2, set the SC trim pot R04 (100k $\Omega$ ) to its maximum value prior to enabling the switch.
- 6.3.4 The data sheet has an equation for calculating the appropriate resistor value for a trimmed output voltage. This value would be the sum of fixed resistor R03 (5.11k $\Omega$ ) and the trim pot R04. R04 can be set using the test points provided locally, or the sum set using the SC and SG test points (Items 3 and 6) when the SC switch is ON.

### 6.4 Activating Adaptive Loop Regulation and Interconnect Compensation CD.

- 6.4.1 The CD switch (#4) and the associated fixed resistor R05 (20 $\Omega$ ) and trim pot R06 (20 $\Omega$ ) enable the PRM™ Adaptive Loop regulation feature, which compensates for the VTM™ output resistance induced voltage drop as the load current from the VTM is increased.
- 6.4.2 This feature is intended to be used with mating VTM-CB discussed in detail in the next section.

## VTM Evaluation Board

The VTM module provides the isolation stage and the output voltage step down. When paired with the PRM the chip set forms a traditional DC-DC converter. Please refer to [UG:014](#) for more information on the VTM evaluation board.

**Figure 4**  
VTM evaluation board

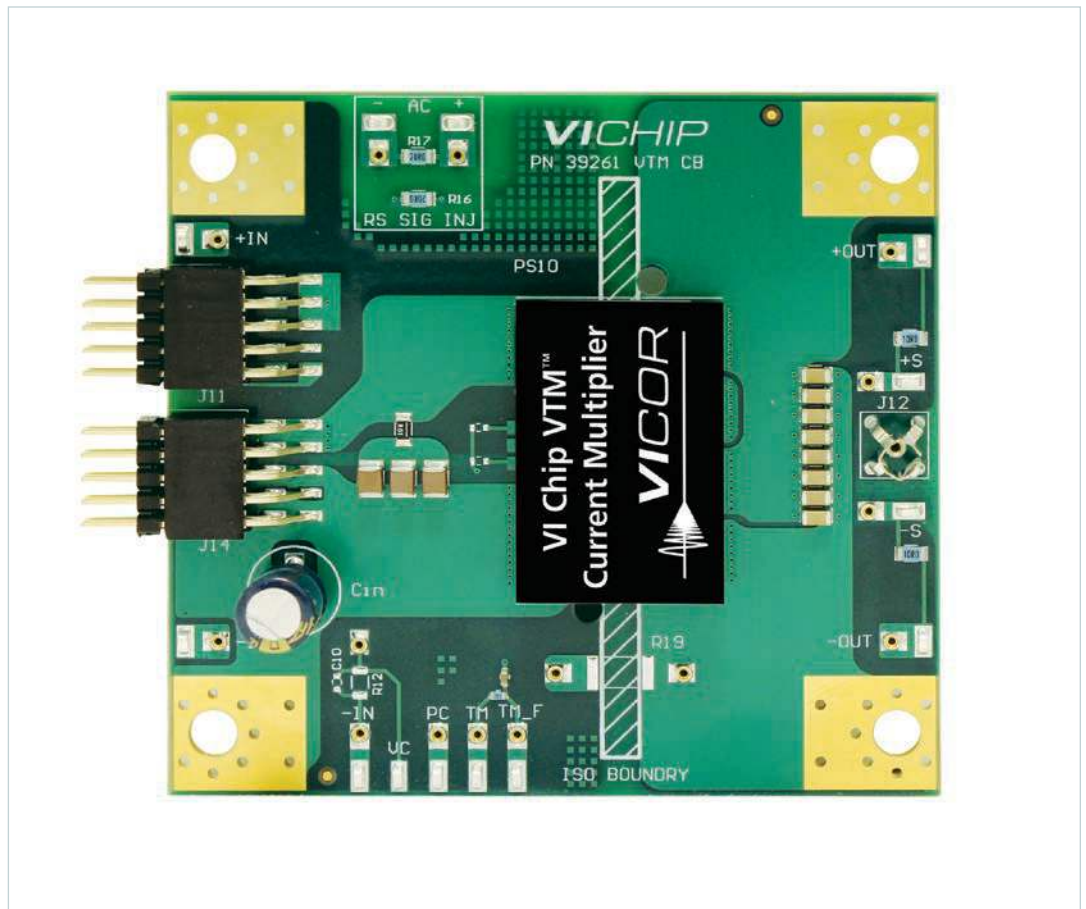



## The DC-DC Converter Chipset

The PRM™ and VTM™ evaluation boards allow the user to select and configure the PRM and VTM to the unique application requirements of their system. By selecting the PRM to accept the desired input voltage, one need only select the VTM to provide the desired output voltage and plug them together if the nominal voltages are all that are required. Refer to [UG:014](#) for information on the VTM evaluation board.

**Figure 5**  
PRM-AL and VTM  
evaluation boards  
(plugged together)

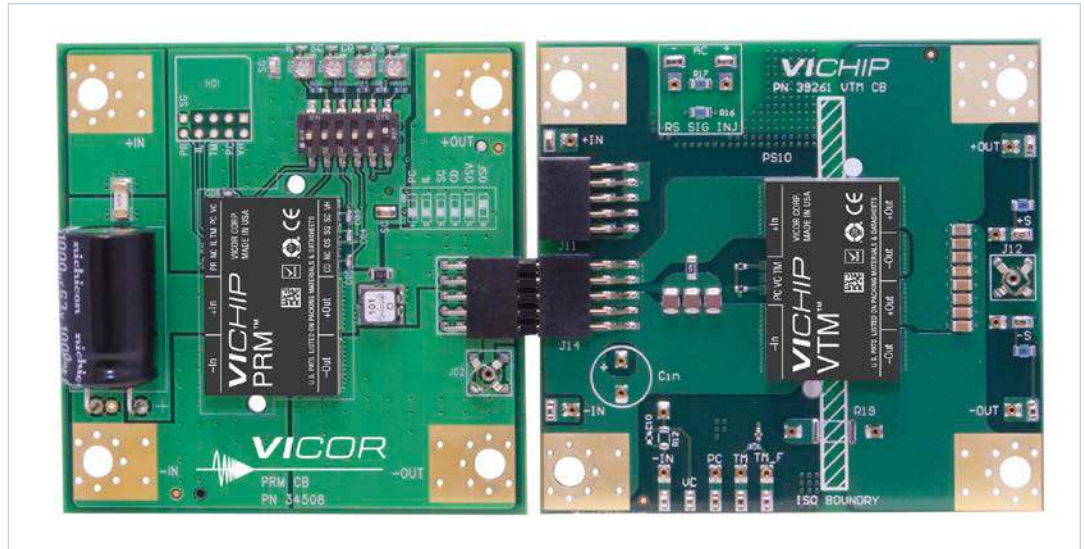

To provide for load regulation at the output of the VTM, the Adaptive Loop regulation mode should be engaged. To activate this feature of the PRM-AL, the switch indicated CD (switch #4) should be set to the ON position. The corresponding trim pot should be set to compensate for the VTM  $R_{OUT}$ , such that the VTM output voltage is regulated at full load. Be certain to refer to the data sheets for the appropriate resistor values for your requirements.

To validate the functionality of the Adaptive Loop regulation, repeat the steps of 2.0 to 5.0 under the section Baseline Test Procedure – PRM-CB except in this instance the output connections are to be made to the VTM-CB output terminals. Both the PRM and VTM data sheets should be in hand. The load current refers to the VTM output current ratings. Be certain to make the connections to the supply and load prior to mating the boards to avoid stressing the connectors.

The PRM Adaptive Loop regulates the output of the VTM without sense lines. The Factorized Bus voltage ( $V_F$ ) may be monitored by using J02 on the PRM-CB board (Item 9) while increasing the load current. Observe the  $V_F$  voltage increases with the load current, compensating for the insertion loss due to the VTM output resistance.

VTM output voltages, which deviate from the nominal configuration, are available by changing the output set point of the PRM as described in Section 6 of this document and using the formula described in the data sheet.

## Ordering Information

The PRM-AL Customer Evaluation Boards are specified by add the suffix “-CB” to the appropriate PRM model number.

---

## Limitation of Warranties

Information in this document is believed to be accurate and reliable. HOWEVER, THIS INFORMATION IS PROVIDED "AS IS" AND WITHOUT ANY WARRANTIES, EXPRESSED OR IMPLIED, AS TO THE ACCURACY OR COMPLETENESS OF SUCH INFORMATION. VICOR SHALL HAVE NO LIABILITY FOR THE CONSEQUENCES OF USE OF SUCH INFORMATION. IN NO EVENT SHALL VICOR BE LIABLE FOR ANY INDIRECT, INCIDENTAL, PUNITIVE, SPECIAL OR CONSEQUENTIAL DAMAGES (INCLUDING, WITHOUT LIMITATION, LOST PROFITS OR SAVINGS, BUSINESS INTERRUPTION, COSTS RELATED TO THE REMOVAL OR REPLACEMENT OF ANY PRODUCTS OR REWORK CHARGES).

Vicor reserves the right to make changes to information published in this document, at any time and without notice. You should verify that this document and information is current. This document supersedes and replaces all prior versions of this publication.

All guidance and content herein are for illustrative purposes only. Vicor makes no representation or warranty that the products and/or services described herein will be suitable for the specified use without further testing or modification. You are responsible for the design and operation of your applications and products using Vicor products, and Vicor accepts no liability for any assistance with applications or customer product design. It is your sole responsibility to determine whether the Vicor product is suitable and fit for your applications and products, and to implement adequate design, testing and operating safeguards for your planned application(s) and use(s).

VICOR PRODUCTS ARE NOT DESIGNED, AUTHORIZED OR WARRANTED FOR USE IN LIFE SUPPORT, LIFE-CRITICAL OR SAFETY-CRITICAL SYSTEMS OR EQUIPMENT. VICOR PRODUCTS ARE NOT CERTIFIED TO MEET ISO 13485 FOR USE IN MEDICAL EQUIPMENT NOR ISO/TS16949 FOR USE IN AUTOMOTIVE APPLICATIONS OR OTHER SIMILAR MEDICAL AND AUTOMOTIVE STANDARDS. VICOR DISCLAIMS ANY AND ALL LIABILITY FOR INCLUSION AND/OR USE OF VICOR PRODUCTS IN SUCH EQUIPMENT OR APPLICATIONS AND THEREFORE SUCH INCLUSION AND/OR USE IS AT YOUR OWN RISK.

## Terms of Sale

The purchase and sale of Vicor products is subject to the Vicor Corporation Terms and Conditions of Sale which are available at: (<http://www.vicorpower.com/termsconditions/warranty>)

## Export Control

This document as well as the item(s) described herein may be subject to export control regulations. Export may require a prior authorization from U.S. export authorities.

Contact Us: <http://www.vicorpower.com/contact-us>

**Vicor Corporation**  
25 Frontage Road  
Andover, MA, USA 01810  
Tel: 800-735-6200  
Fax: 978-475-6715  
[www.vicorpower.com](http://www.vicorpower.com)

### email

Customer Service: [custserv@vicorpower.com](mailto:custserv@vicorpower.com)  
Technical Support: [apps@vicorpower.com](mailto:apps@vicorpower.com)