

# Development Board EPC90146 Quick Start Guide

*100 V Half-bridge with Gate Drive using EPC2071*

Revision 3.0



DESCRIPTION

The EPC90146 is a half bridge development board with onboard gate driver, featuring the 100 V rated EPC2071 eGaN® FET. The purpose of this development board is to simplify the evaluation process of the EPC2071 by including all the critical components on a single board that can be easily integrated into most existing converter topologies.

The EPC90146 development board measures 2" x 2" and contains two EPC2071 eGaN FETs in a half bridge configuration and one EPC2038 GaN FET used to augment the bootstrap supply. The EPC90146 features the uPI Semiconductor uP1966E gate driver. The board contains all critical components, and the layout supports optimal switching performance. There are also various probe points to facilitate simple waveform measurement and efficiency calculation. A block diagram of the circuit is given in figure 1.

For more information on [EPC2071](#) and [EPC2308](#) please refer to their datasheets available from EPC at [www.epc-co.com](http://www.epc-co.com). The datasheet should be read in conjunction with this quick start guide.

Table 1: Performance Summary (T<sub>A</sub> = 25°C) EPC90146

Symbol	Parameter	Conditions	Min	Nominal	Max	Units
V <sub>DD</sub>	Gate Drive Regulator Supply Range		7.5		12	V
V <sub>IN</sub>	Bus Input Voltage Range <sup>(1)</sup>				80	
I <sub>OUT</sub>	Switch Node Output Current <sup>(2)</sup>				45	A
V <sub>PWM</sub>	PWM Logic Input Voltage Threshold <sup>(3)</sup>	Input 'High'	3.5		5.5	V
		Input 'Low'	0		1.5	
	PWM 'High' State Input Pulse Width	V <sub>PWM</sub> rise and fall time < 10 ns	50			ns
	PWM 'Low' State Input Pulse Width <sup>(4)</sup>	V <sub>PWM</sub> rise and fall time < 10 ns	200			

- (1) Maximum input voltage depends on inductive loading, maximum switch node ringing must be kept under 100 V for EPC2071.
- (2) Maximum current depends on die temperature – actual maximum current is affected by switching frequency, bus voltage and thermal cooling.
- (3) When using the on board logic buffers, refer to the uP1966E datasheet when bypassing the logic buffers.
- (4) Limited by time needed to 'refresh' high side bootstrap supply voltage.

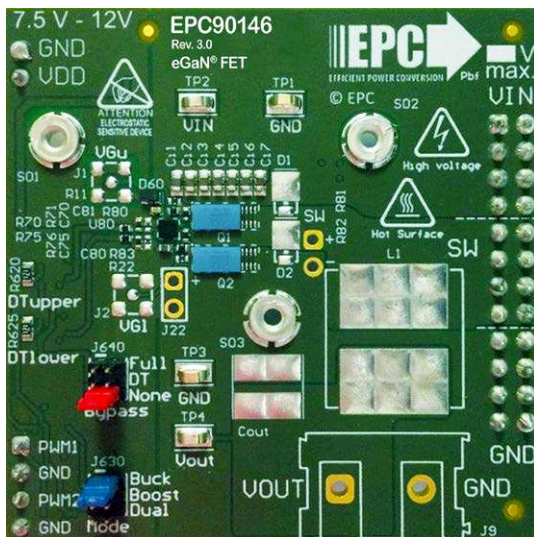

Front view



Back view

EPC90146 development board

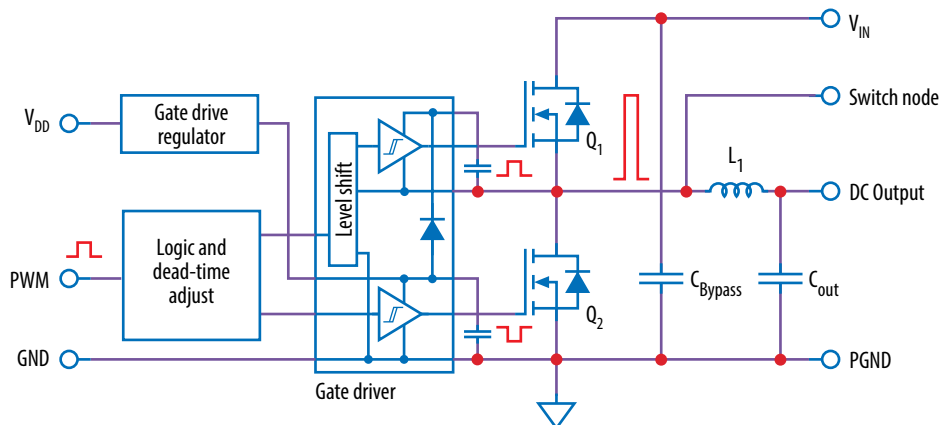

Figure 1: Block diagram of EPC90146 development board default configuration

### QUICK START PROCEDURE

The EPC90146 development board is easy to set up as a buck or boost converter to evaluate the performance of the two EPC2071 EGaN FETs. This board includes a dead-time generating circuit that adds a delay from when the gate signal of one FET is commanded to turn off, to when the gate signal of the other FET is commanded to turn on. In the default configuration, this dead time circuit ensures that both the high and low side FETs will not be turned on at the same time thus preventing a shoot-through condition. The dead-time and/or polarity changing circuits can be utilized or bypassed for added versatility.

#### Single/dual PWM signal input settings

There are two PWM signal input ports on the board, PWM1 and PWM2. Both input ports are used as inputs in dual-input mode where PWM1 connects to the upper FET and PWM2 connects to the lower FET. The PWM1 input port is used as the input in single-input mode where the circuit will generate the required complementary PWM for the FETs. The input mode is set by choosing the appropriate jumper positions for J630 (mode selection) as shown in figure 2(a) for a **single-input buck converter** (blue jumper across pins 1 & 2 of J630), (b) for a **single-input boost converter** (blue jumpers across pins 3 & 4 of J630), and (c) for a **dual-input operation** (blue jumpers across pins 5 & 6 of J630).

**Note:** In dual mode there is no shoot-through protection as both gate signals can be set high at the same time.

#### Dead-time settings

*Dead-time* is defined as the time between when one FET turns off and the other FET turns on, and for this board is referenced to the input of the gate driver. The dead-time can be set to a specific value where resistor R620 delays the turn on of the upper FET and resistor R625 delays the turn on of the lower FET as illustrated in figure 3.

The required resistance for the desired dead-time setting can be read off the graph in figure 4. An example for 10 ns dead-time setting shows that a 120 Ω resistor is needed.

**Note:** This is the default deadtime and resistor value installed. A minimum dead-time of is 5 ns and maximum of 15 ns is recommended.

#### Bypass settings

Both the polarity changer and the deadtime circuits can be bypassed using the jumper settings on J640 (Bypass), for direct access to the gate driver input. There are three bypass options: 1) No bypass, 2) Dead-time bypass, 3) Full bypass. The jumper positions for J640 for all three bypass options are shown in figure 5.

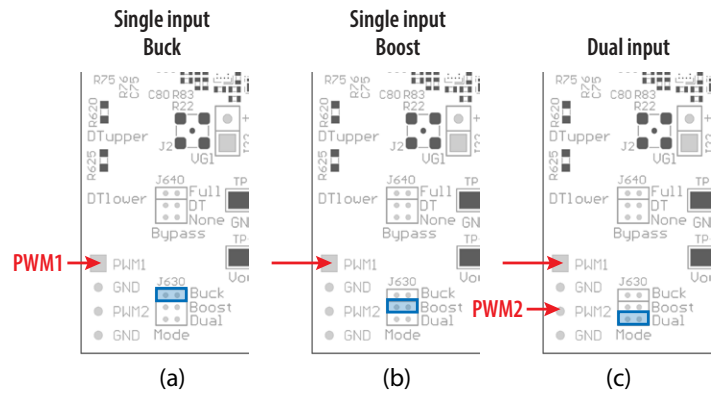

Figure 2: Input mode selection on J630

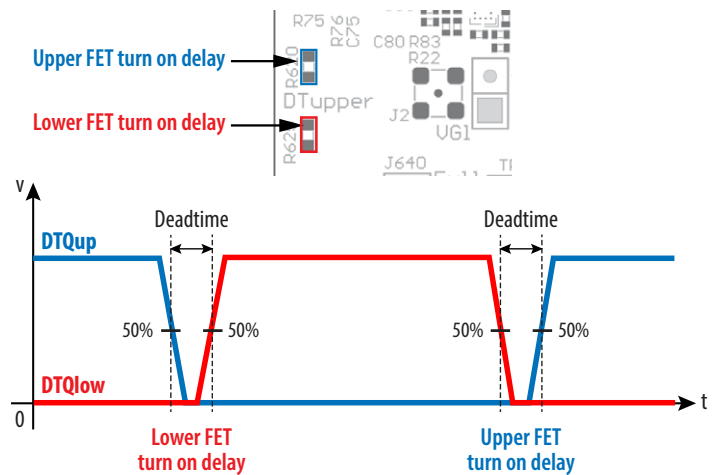

Figure 3: Definition of dead-time between the upper-FET gate signal (DTQup) and the lower-FET gate signal (DTQlow)



Figure 4: The required resistance values for R620 or R625 as a function of desired dead-time

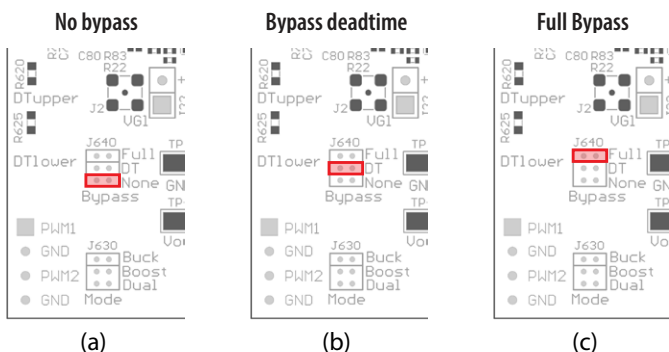

Figure 5: Bypass mode Jumper settings for J640

In **no-bypass mode**, figure 5(a) (red jumper across pins 5 & 6 of J640), both the on-board polarity and dead-time circuits are fully utilized. In **dead-time bypass mode**, figure 5(b) (red jumpers across pins 3 & 4 of J640), only the on-board polarity changer circuit is utilized, effectively bypassing the dead-time circuit. In **full bypass mode**, Figure 5(c) (red jumper across pins 1 & 2 of J640), the inputs to the gate driver are directly connected to the PWM1 and PWM2 pins and the on-board polarity and dead-time circuits are not utilized.

**Buck converter configuration**

To operate the board as a buck converter, either a single or dual PWM inputs can be chosen using the appropriate jumper settings on J630 (mode).

To select **Single Input Buck Mode**, the bypass jumper J640 **must** be set to the **no-bypass mode**, the **buck mode** J630 **must** be selected as shown in figure 6(a).

To select **Dual Input Buck Mode**, the bypass jumper J640 **may** be configured to any of the valid settings, the dual-input mode J630 **must** be selected as shown in figure 6(b).

**Note:** It is important to provide the correct PWM signals that includes dead-time and polarity when operating in bypass mode.

Once the input source, dead-time settings and bypass configurations have been chosen and set, then the boards can be operated.

1. With power off, connect the input power supply bus to VIN and ground / return to GND.
2. With power off, connect the switch node (SW) of the half bridge to your circuit as required (half bridge configuration). Or use the provided pads for inductor (L1) and output capacitors (Cout), as shown in figure 6.
3. With power off, connect the gate drive supply to V<sub>DD</sub> (J3, Pin-2) and ground return to GND (J3, Pin-1 indicated on the bottom side of the board).
4. With power off, connect the input PWM control signal to PWM1 and/or PWM2 according to the input mode setting chosen and ground return to any of GND J80 pins indicated on the bottom side of the board.
5. Turn on the gate drive supply – make sure the supply is between 7.5 V and 12 V.
6. Turn on the controller / PWM input source.
7. Making sure the initial input supply voltage is 0 V, turn on the power and slowly increase the voltage to the required value (**do not exceed the absolute maximum voltage**). Probe switch-node to see switching operation.
8. Once operational, adjust the PWM control, bus voltage, and load within the operating range and observe the output switching behavior, efficiency, and other parameters.
9. For shutdown, please follow steps in reverse.

**Bypass mode warnings**

- **It is important to provide the correct PWM signals that includes dead-time and polarity for either buck or boost operation when making use of bypass modes.**
- When operating in **full bypass mode**, the input signal specifications revert to that of the uP1966E gate driver IC. Refer to the uP1966E datasheet for details.

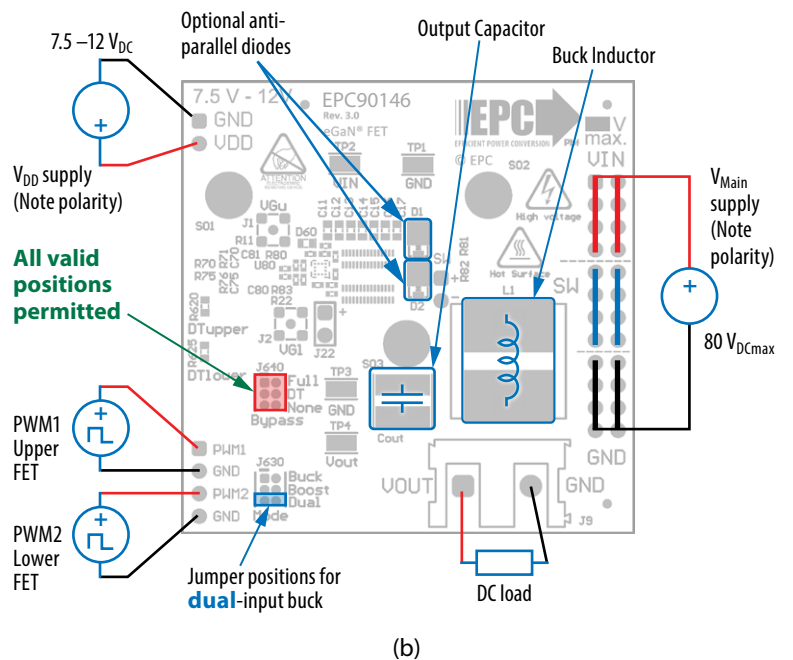
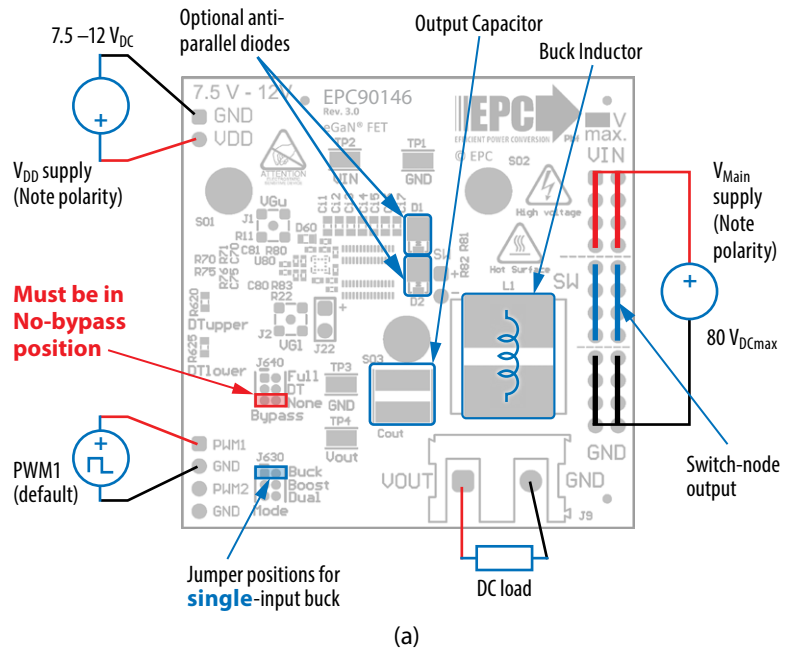

Figure 6: (a) Single-PWM input buck converter (b) Dual-PWM input buck converter configurations showing the supply, anti-parallel diodes, output capacitor, inductor, PWM, and load connections with corresponding jumper positions.

**Boost Converter configuration**

**Warning:** Never operate the boost converter mode without a load, as the output voltage can increase beyond the maximum ratings.

To operate the board as a boost converter, either a single or dual PWM inputs can be chosen using the appropriate jumper settings on J630 (mode).

To select **Single Input Boost Mode**, the bypass jumper J640 **must** be set to the **no-bypass mode**, the boost mode J630 **must** be selected as shown in figure.7(a).

To select **Dual Input Boost Mode**, the bypass jumper J640 **may** be configured to any of the valid settings, the **dual-input mode** J630 **must** be selected as shown in figure 7(b).

**Note:** It is important to provide the correct PWM signals that includes dead-time and polarity when operating in bypass mode.

Once the input source, dead-time settings and bypass configurations have been chosen and set, then the boards can be operated.

1. The inductor (L1) and input capacitors (labeled as Cout) can either be soldered onto the board, as shown in figure 7, or provided off board. Anti-parallel diodes can also be installed using the additional pads on the right side of the EPC2071 FETs.
2. With power off, connect the input power supply bus to V<sub>OUT</sub> and ground / return to GND, or externally across the capacitor if the inductor L1 and Cout are provided externally. Connect the output voltage (labeled as VIN) to your circuit as required, e.g., resistive load.
3. With power off, connect the gate drive supply to VDD (J3, Pin-2) and ground return to GND (J3, Pin-1 indicated on the bottom side of the board).
4. With power off, connect the input PWM control signal to PWM1 and/or PWM2 according to the input mode setting chosen and ground return to any of GND J80 pins indicated on the bottom side of the board.
5. Turn on the gate drive supply – make sure the supply is between 7.5 V and 12 V.
6. Turn on the controller / PWM input source.
7. **Making sure the output is not open circuit**, and the input supply voltage is initially 0 V, turn on the power and slowly increase the voltage to the required value (**do not exceed the absolute maximum voltage**). Probe switch-node to see switching operation.
8. Once operational, adjust the PWM control, bus voltage, and load within the operating range and observe the output switching behavior, efficiency, and other parameters. Observe device temperature for operational limits.
9. For shutdown, please follow steps in reverse.

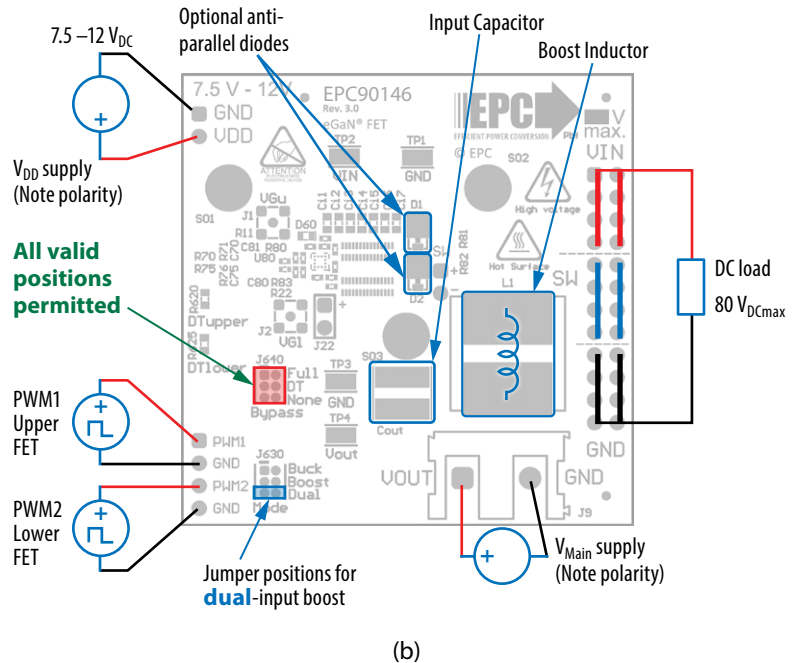
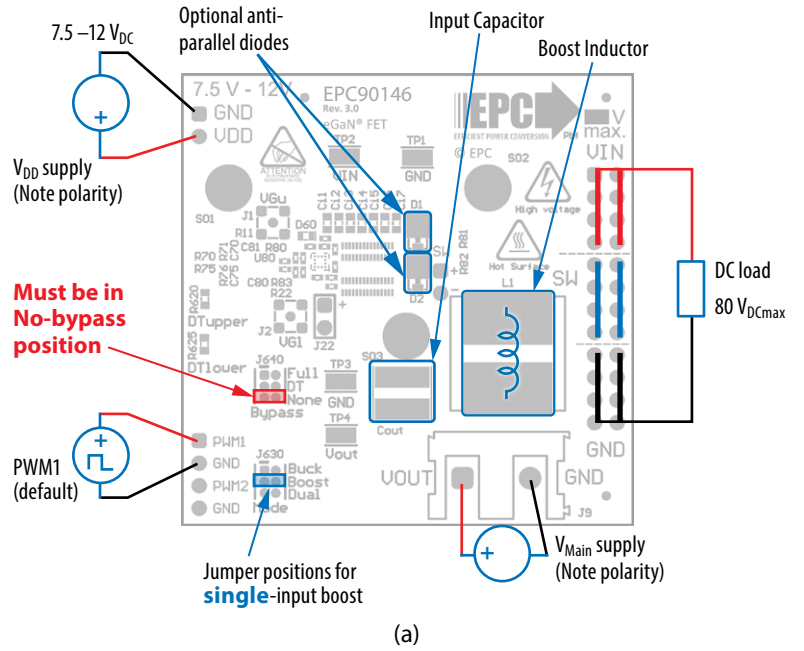

Figure 7: (a) Single-PWM input boost converter (b) Dual-PWM input boost converter configurations showing the supply, inductor, anti-parallel diodes, input capacitor, PWM, and load connections with corresponding jumper settings.

### MEASUREMENT CONSIDERATIONS

Measurement connections are shown in figure 8.

When measuring the switch node voltage containing high-frequency content, care must be taken to provide an accurate high-speed measurement. An optional two pin header (J33) and an MMCX connector (J32) is provided for switch-node measurement.

A differential probe is recommended for measuring the high-side gate voltage (J1). IsoVu probes from Tektronix has mating MMCX connector.

For regular passive voltage probes (e.g. TPP1000) measuring switch node using MMCX connector, probe adaptor is available. PN: 206-0663-xx.

**NOTE.** For information about measurement techniques, the EPC website offers: [“AN023 Accurately Measuring High Speed GaN Transistors”](#) and the [How to GaN educational video series](#), including: [HTG09- Measurement](#)

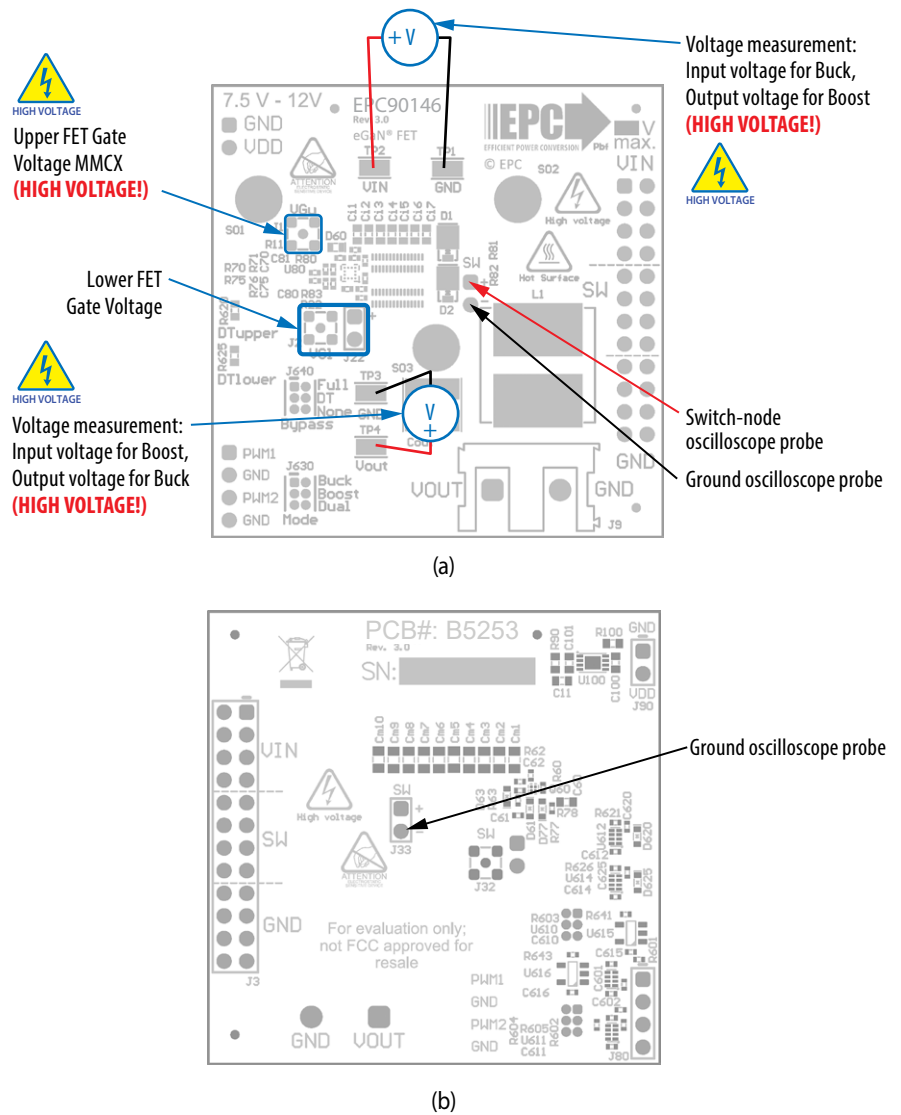

Figure 8: Measurement points (a) top side, (b) bottom side

### THERMAL CONSIDERATIONS

The EPC90146 board is equipped with three mechanical spacers that can be used to easily attach a heat-spreader or heatsink as shown in figure 9 (a), and only requires a thermal interface material (TIM), a custom shape heat-spreader/heatsink, and screws. Prior to attaching a heat-spreader, any component exceeding 1 mm in thickness under the heat-spreader area will need to be removed from the board as shown in figure 9 (b).

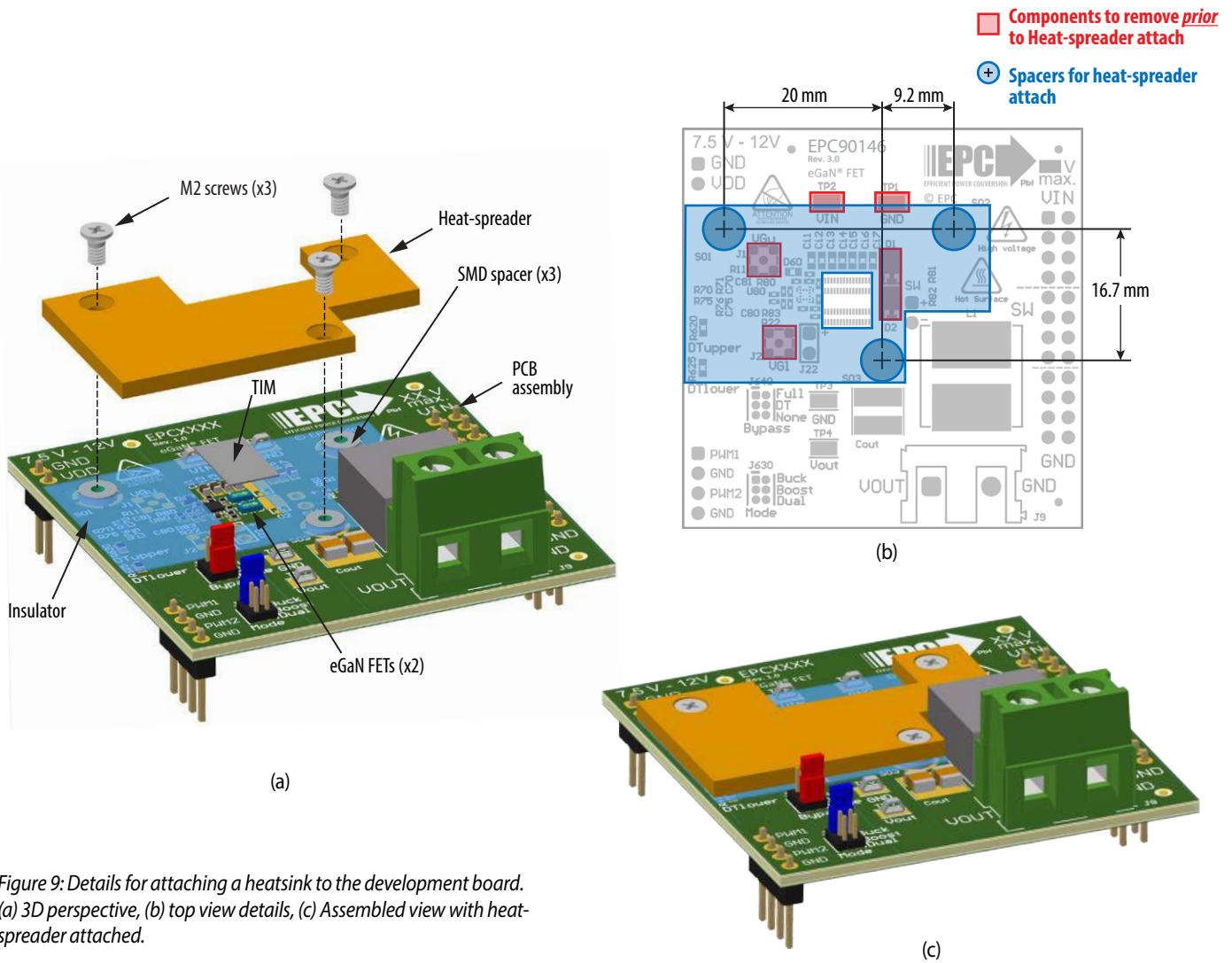

Figure 9: Details for attaching a heatsink to the development board. (a) 3D perspective, (b) top view details, (c) Assembled view with heat-spreader attached.

The design of the heat-spreader is shown in figure 10 and can be made using **aluminum** or **copper** for higher performance.

The heat-spreader is held in place using countersunk screws that fasten to the mechanical spacers which will accept M2 x 0.4 mm thread screws such as McMasterCarr 91294A002.

When assembling the heatsink, it may be necessary add a thin insulation layer to prevent the heat-spreader from short circuiting with components that have exposed conductors such as capacitors and resistors, as shown in figure 10. **Note that the heat-spreader is ground connected by the lower most mounting post.** A rectangular opening in the insulator must be provided to allow the TIM to be placed over the FETs to be cooled with a minimum clearance of 3 mm on each side of the rectangle encompassing the FETs. The TIM will then be similar in size or slightly smaller than the opening in the insulator shown by the red dashed outline in figure 11.

EPC recommends Laird P/N: A14692-30, Tgard™ K52 with thickness of 0.051 mm the for the insulating material.

A TIM is added to improve the interface thermal conductance between the FETs and the attached heat exchanger. The choice of TIM needs to consider the following characteristics:

- **Mechanical compliance** – During the attachment of the heat spreader, the TIM underneath is compressed from its original thickness to the vertical gap distance between the spacers and the FETs. This volume compression exerts a force on the FETs. A maximum compression of 2:1 is recommended for maximum thermal performance and to constrain the mechanical force which maximizes thermal mechanical reliability.
- **Electrical insulation** – The backside of the eGaN FET is a silicon substrate that is connected to source and thus the upper FET in a half-bridge configuration is connected to the switch-node. To prevent short-circuiting the switch-node to the grounded thermal solution, the TIM must be of high dielectric strength to provide adequate electrical insulation in addition to its thermal properties.
- **Thermal performance** – The choice of thermal interface material will affect the thermal performance of the thermal solution. Higher thermal conductivity materials is preferred to provide higher thermal conductance at the interface.

EPC recommends the following thermal interface materials:

- **t-Global** P/N: TG-A1780 X 0.5 mm (highest conductivity of 17.8 W/m-K)
- **t-Global** P/N: TG-A620 X 0.5 mm (moderate conductivity of 6.2 W/m-K)
- **Bergquist** P/N: GP5000-0.02 (~0.5 mm with conductivity of 5 W/m-K)
- **Bergquist** P/N: GPTGP7000ULM-0.020 (conductivity of 7 W/m-K)

**NOTE.** The EPC90146 development board does not have any current or thermal protection on board. For more information regarding the thermal performance of EPC eGaN FETs, please consult: D. Reusch and J. Glaser, *DC-DC Converter Handbook, a supplement to GaN Transistors for Efficient Power Conversion*, First Edition, Power Conversion Publications, 2015.

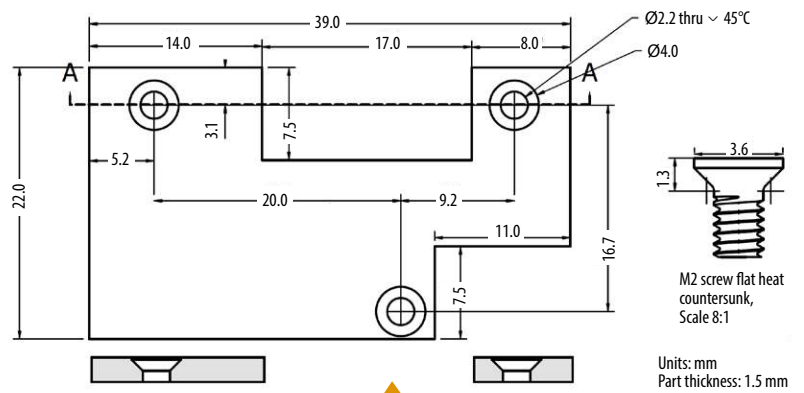

Figure 10: Heat-spreader details

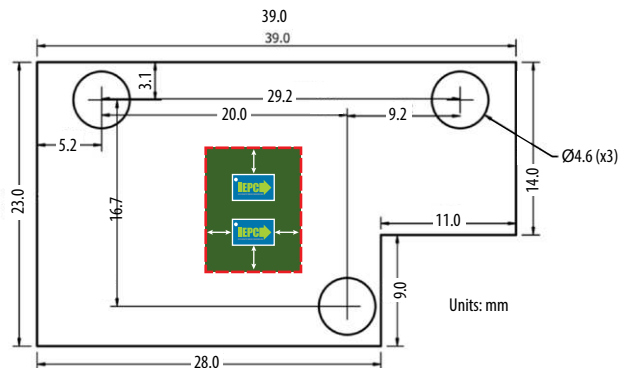
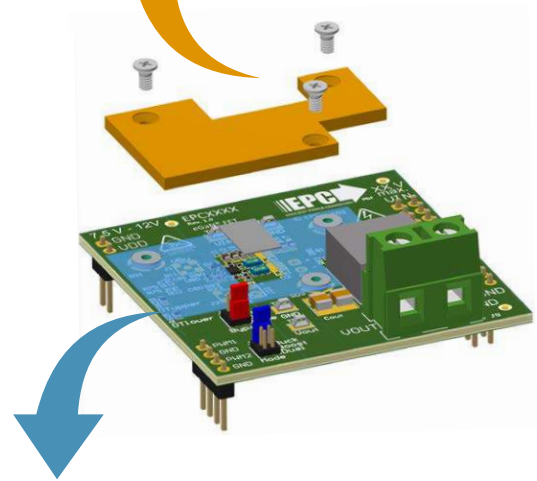

Figure 11: Insulator sheet details with opening for the TIM with location of the FETs



### EXPERIMENTAL VALIDATION

The performance of EPC90146 was tested under the operating conditions given in table 2 unless otherwise specified.

A heat-spreader per figures 10 and 11 with t-Global TG-A1780 thermal interface material (TIM) and a heatsink from Wakefield Vette 567-24AB using the same TIM was added to the board prior to testing at high current.

Additional input and output capacitance are added to suppress input and output voltage ripple at high output current as shown in Table 2.

**Table 2: Test Conditions**

Parameter	Max	Units
Regulated Input voltage	64	V
Regulated Output voltage	12	V
Switching frequency ( $f_s$ )	250	kHz
Inductor (mounted on Filter Card 1)	2.2	$\mu\text{H}^{(1)}$
Additional Input capacitance (min.)	470	$\mu\text{F}^{(2)}$
Additional Output capacitance (min.)	23.5	$\mu\text{F}^{(3)}$
Maximum case temperature	110	$^{\circ}\text{C}$
Dead time	10	ns

(1) 2.2  $\mu\text{H}$  inductor from Coilcraft, P/N IHTH1125KZEB2R2M5A.

(2) Capacitors used: 470  $\mu\text{F}$ , 250 V, x1 (P/N: UPT2E471MRD)

(3) Capacitors used: 4.7  $\mu\text{F}$ , 250 V, x5 (P/N: GMC32X7R475K100NT)

### ELECTRICAL PERFORMANCE

#### Measure Waveforms

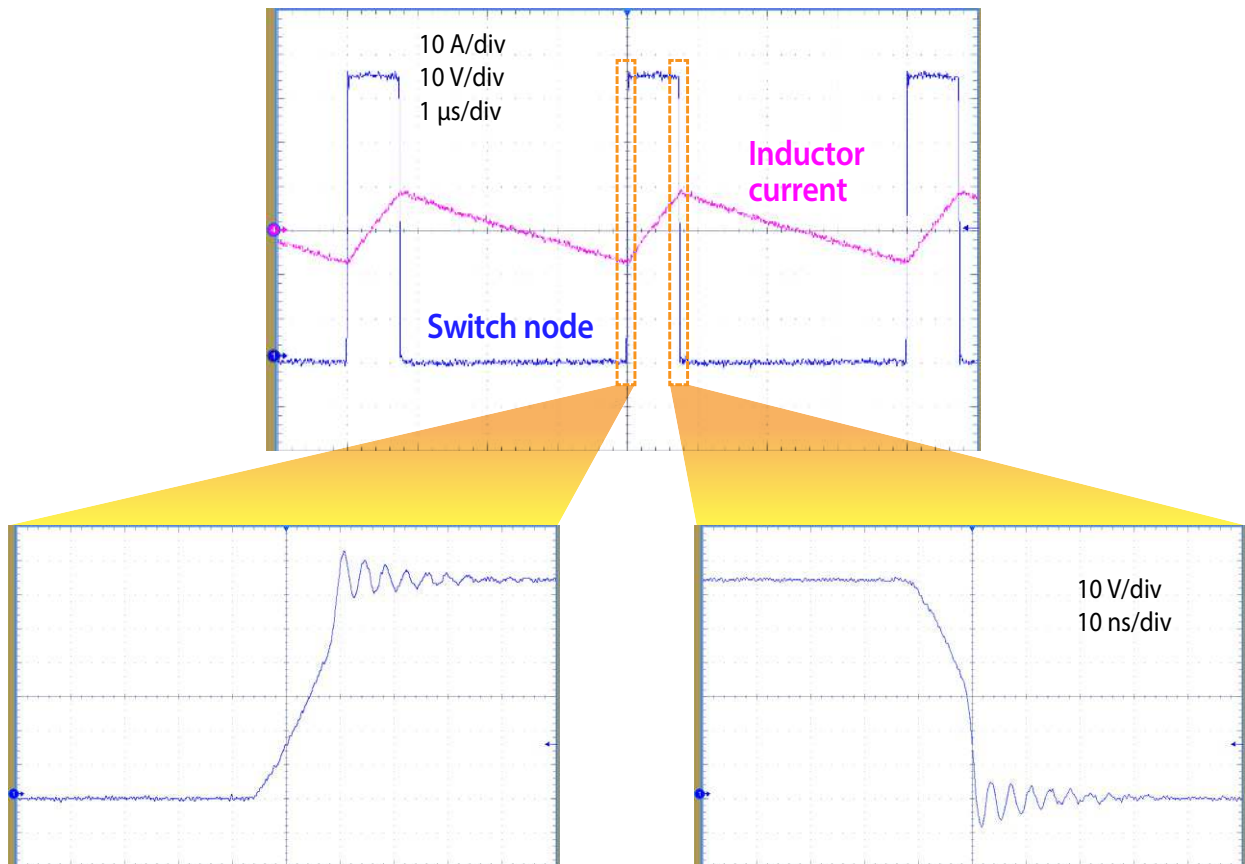

Figure 12: Measured inductor current and switch node waveforms when operating from 64 V at 250 kHz and delivering 0 A into a 12 V load

Measure Waveforms (continued)

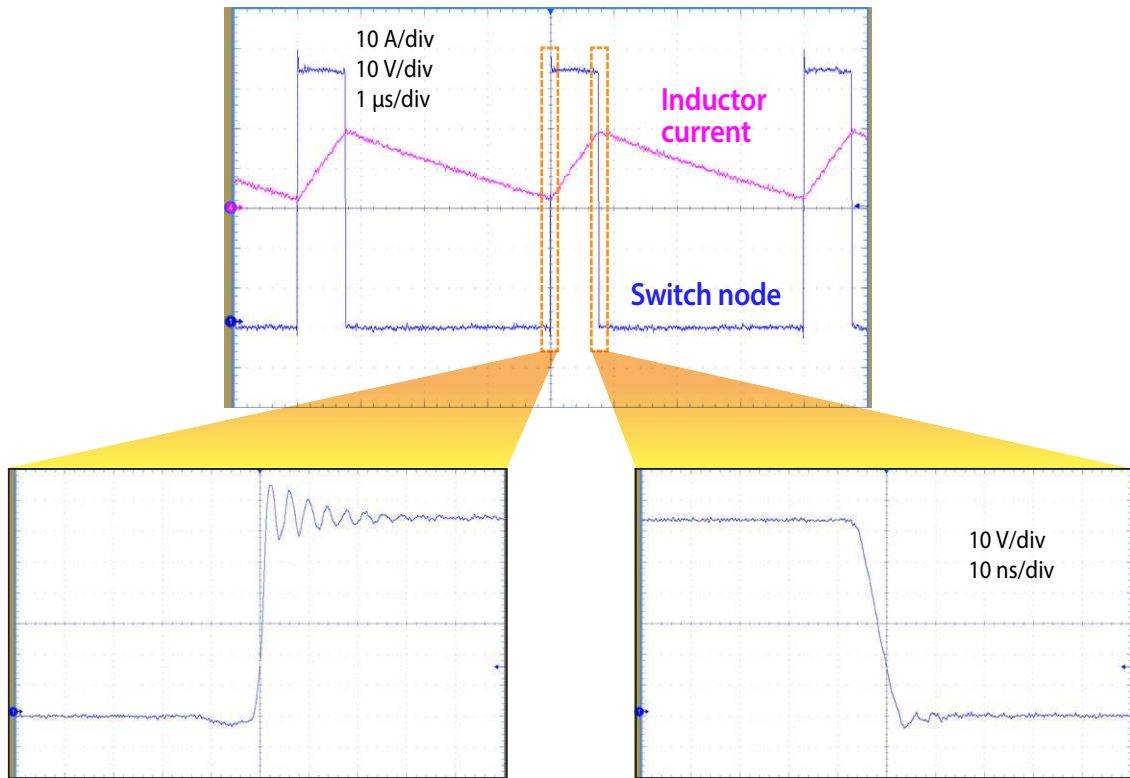

Figure 13: Measured inductor current and switch node waveforms when operating from 64 V at 250 kHz and delivering 10 A into a 12 V load

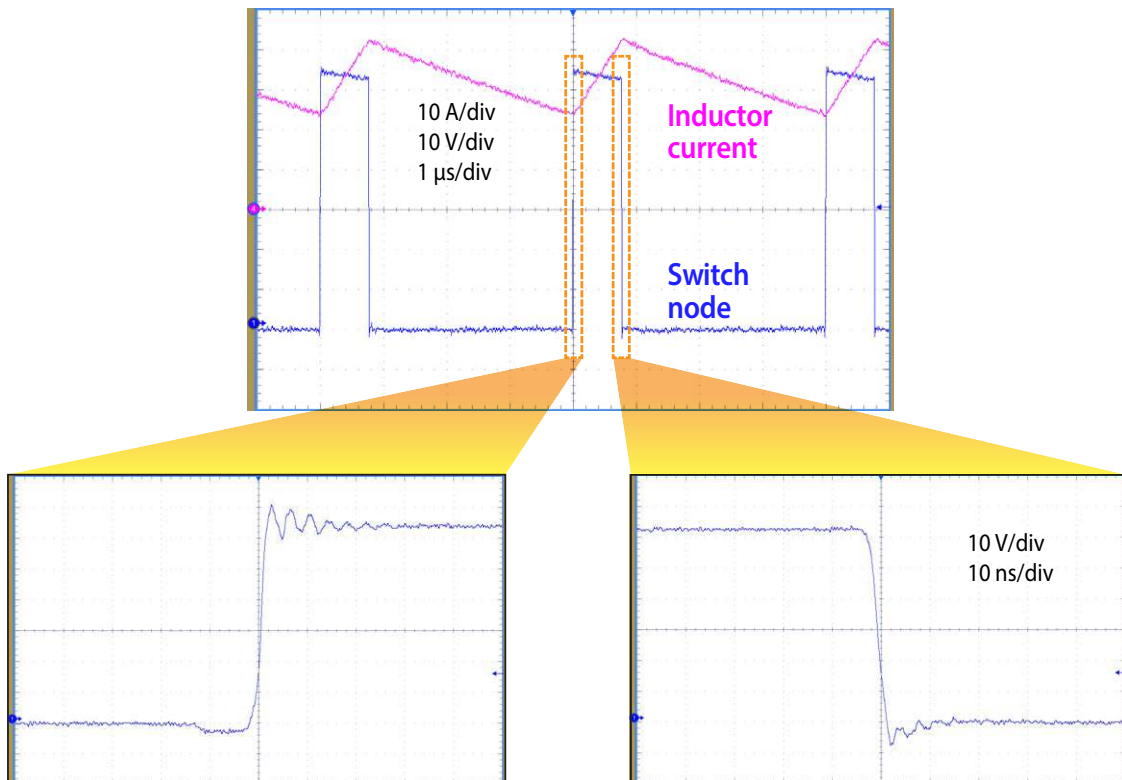

Figure 14: Measured inductor current and switch node waveforms when operating from 64 V at 250 kHz and delivering 32 A into a 12 V load

### EFFICIENCY and POWER LOSSES

Figure 15 shows the efficiency and power loss results when operating from 64 V to 12 V at various switching frequencies using a 2.2  $\mu\text{H}$  inductor.

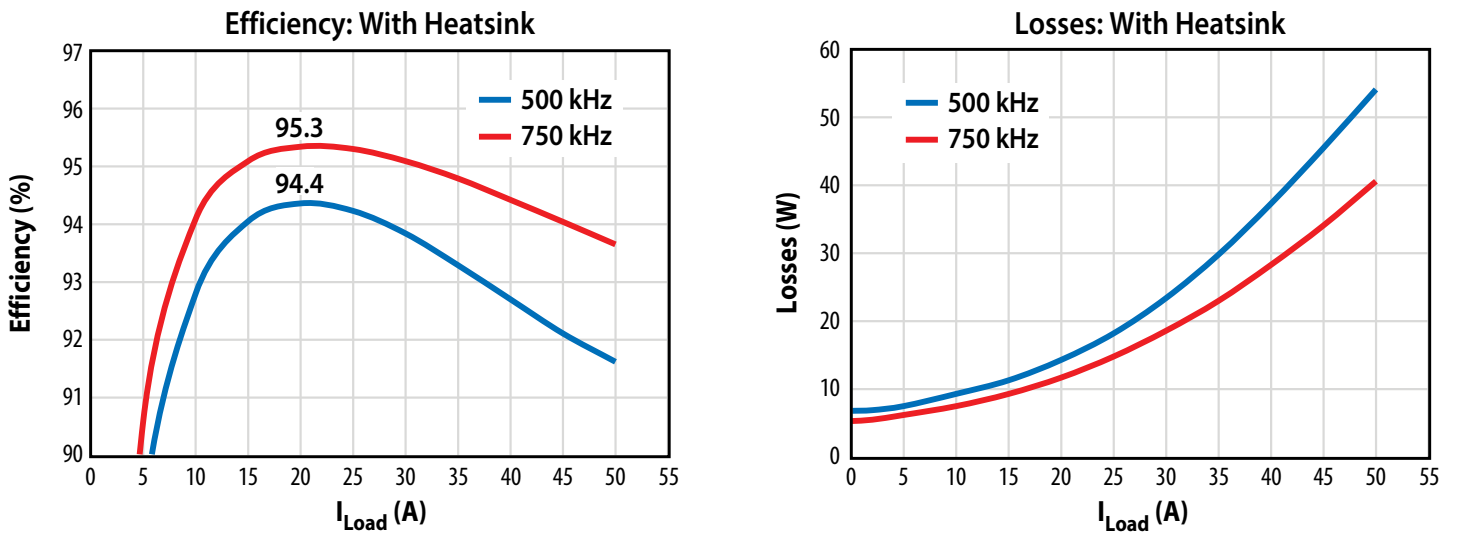

Figure 15: Measured efficiency and power loss operating at various switching frequencies and using  $L = 2.2 \mu\text{H}$

### THERMAL PERFORMANCE

Figure 16 shows the thermal performance of the board fitted with a heatsink and heat-spreader when operating at 64 V delivering 12 V into the load with 1000-1500 LFM (high) airflow.

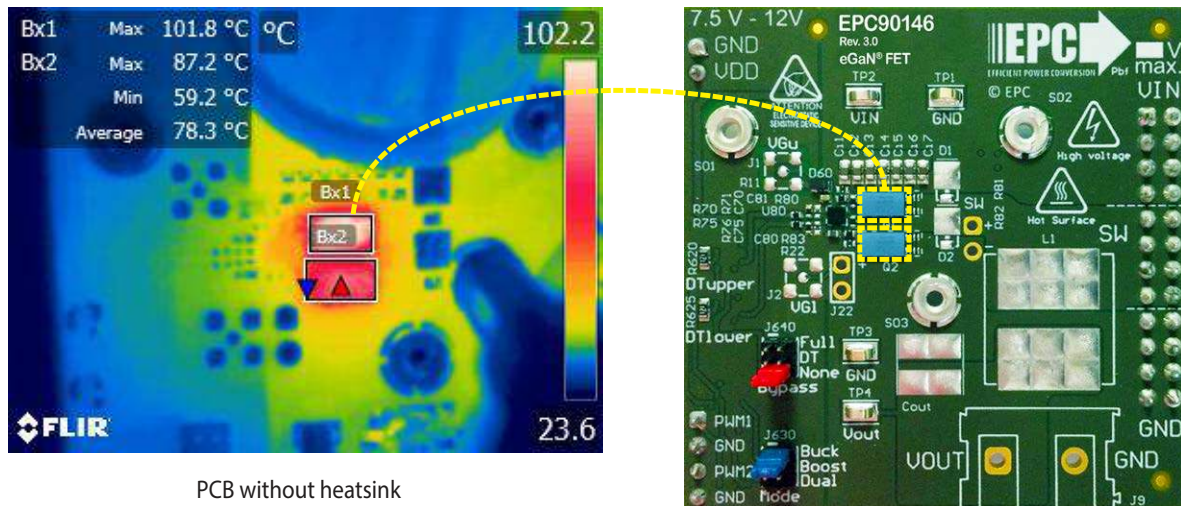

Figure 16: Measured thermal image and thermal couple readings of case temperature when operating under the following conditions:  $f_s = 250 \text{ kHz}$ ,  $I_{OUT} = 32 \text{ A}$  output, 25°C ambient and high air flow

### THERMAL DERATING

Using the thermal setup for the board, additional testing at 500 LFM and 1000 LFM was conducted to determine the ambient temperature derating for the board with and without a heatsink attached. The temperature rise as function of load current is measured and the derating curves generated for a maximum case temperature of 110°C and shown in figure 17 for various switching frequencies.

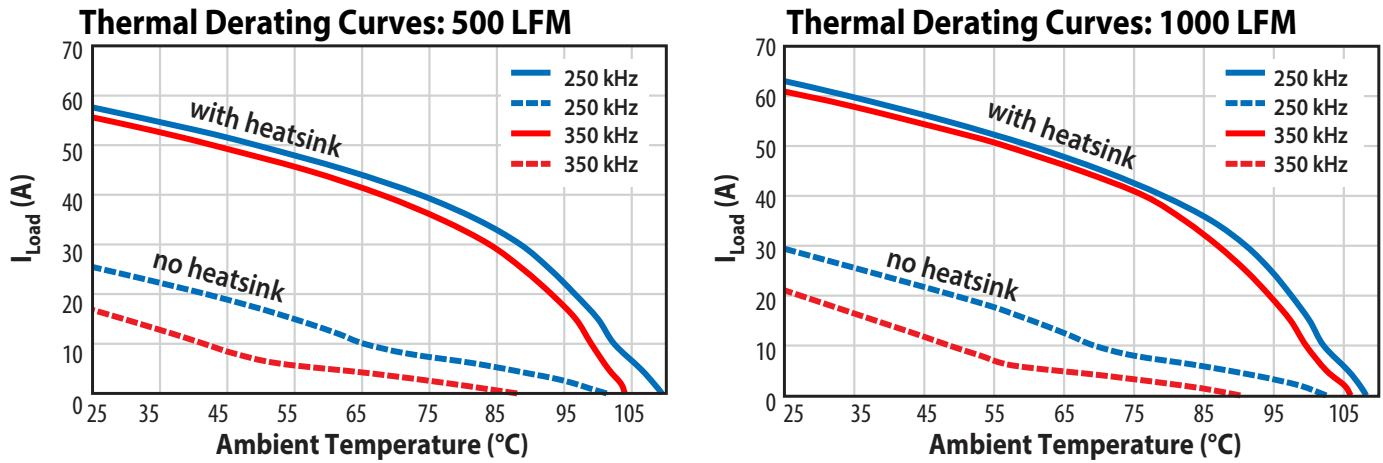

Figure 17: Typical thermal derating curve for two air flow rates, with and without a heatsink attached, measured with the board operating at various switching frequencies and using a 2.2 μH inductor

For support files including schematic, Bill of Materials (BOM), and gerber files please visit the EPC90146 landing page at: <https://epc-co.com/epc/Products/Demo-Boards/EPC90146>

## For More Information:

Please contact [info@epc-co.com](mailto:info@epc-co.com)  
or your local sales representative

Visit our website:  
[www.epc-co.com](http://www.epc-co.com)

Sign-up to receive  
EPC updates at  
[bit.ly/EPCupdates](http://bit.ly/EPCupdates)



EPC Products are distributed through Digi-Key.  
[www.digikey.com](http://www.digikey.com)

### Demonstration Board Notification

**The EPC90146 board is intended for product evaluation purposes only. It is not intended for commercial use nor is it FCC approved for resale.** Replace components on the Evaluation Board only with those parts shown on the parts list (or Bill of Materials) in the Quick Start Guide. Contact an authorized EPC representative with any questions. This board is intended to be used by certified professionals, in a lab environment, following proper safety procedures. Use at your own risk.

As an evaluation tool, this board is not designed for compliance with the European Union directive on electromagnetic compatibility or any other such directives or regulations. As board builds are at times subject to product availability, it is possible that boards may contain components or assembly materials that are not RoHS compliant. Efficient Power Conversion Corporation (EPC) makes no guarantee that the purchased board is 100% RoHS compliant.

The Evaluation board (or kit) is for demonstration purposes only and neither the Board nor this Quick Start Guide constitute a sales contract or create any kind of warranty, whether express or implied, as to the applications or products involved.

Disclaimer: EPC reserves the right at any time, without notice, to make changes to any products described herein to improve reliability, function, or design. EPC does not assume any liability arising out of the application or use of any product or circuit described herein; neither does it convey any license under its patent rights, or other intellectual property whatsoever, nor the rights of others.