

**DESIGNED & DIMENSIONED
IN MILLIMETERS [INCHES]**



**THIS PRODUCT MANUFACTURED
WITH LEAD-FREE PROCESSING**

FCF8-XX-XX-X-XX.XX-S-X

DO NOT
SCALE FROM
THIS PRINT

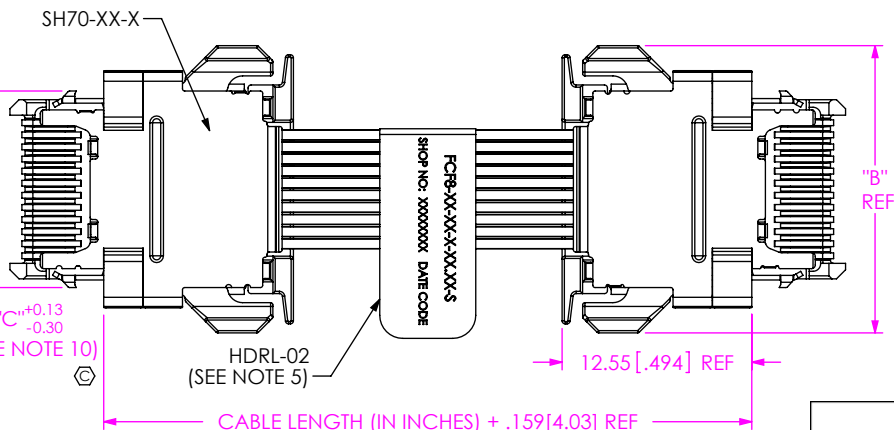
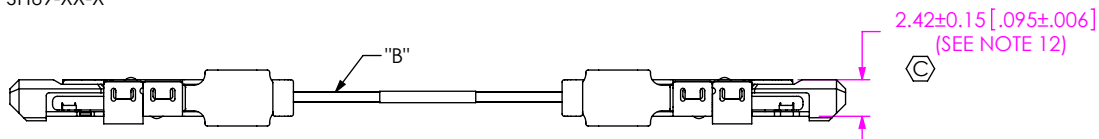
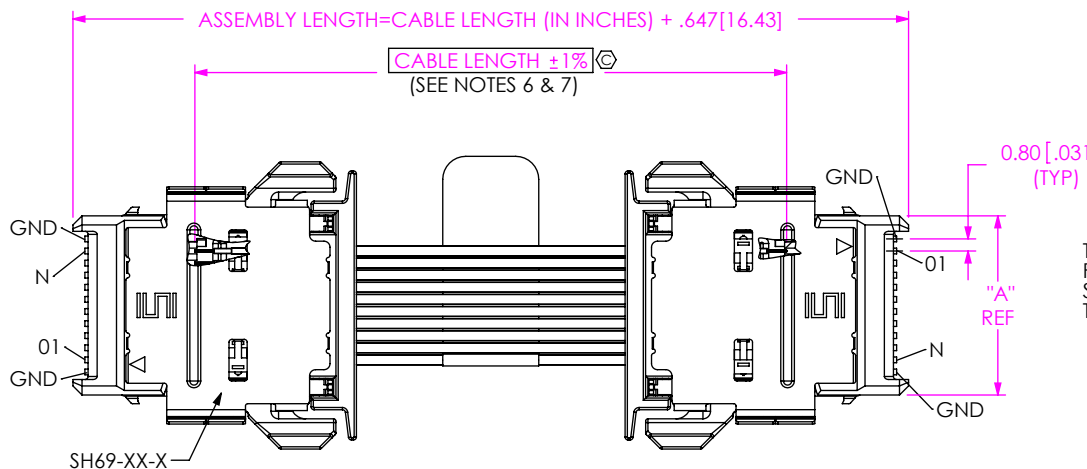

FIG 1
FCF8-10-01-X-XX.XX-S SHOWN

No OF POSITIONS
*-05, -10, *-15, -20
*-25, -30, *-35, *-40

LEAD STYLE
-01: 38 AWG COAX
*-02: 34 AWG TWINAX
*-03: 32 AWG POWER

* = NOT TOOLED

WIRING OPTION
-1: 1 TO 1 (SEE FIG. 2)
(LEAVE BLANK FOR 1 TO N)
ROW SPECIFICATION
-S: SINGLE ROW

CABLE LENGTH (IN INCHES)
-XX.XX: 03.00 [76.2] MIN
(SEE NOTE 6)

PLATING SPECIFICATION
-L: 10µ" SELECTIVE GOLD IN
CONTACT AREA, MATTE TIN ON TAIL

TO DISENGAGE CABLE FROM SOCKET:
FIRST, FULLY SEAT CONNECTOR
SECOND, FULLY DEPRESS LATCH RELEASE
THIRD, PULL STRAIGHT BACK WITH
LATCH RELEASE DEPRESSED

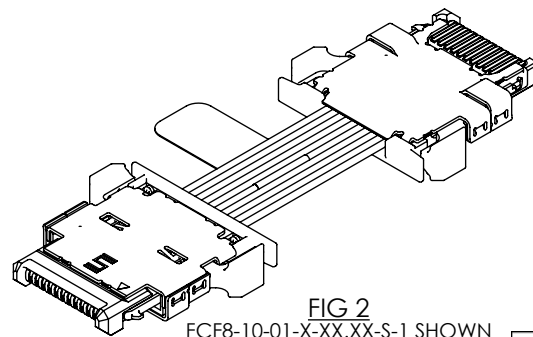
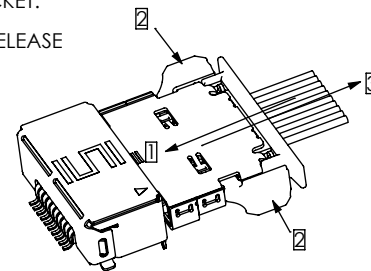

FIG 2
FCF8-10-01-X-XX.XX-S-1 SHOWN

No OF POSITIONS	"N" POSITION
*-05	05
-10	10
*-15	15
-20	20
*-25	25
-30	30
*-35	35
*-40	40

* NOT TOOLED

POSITION	"A"	"B"	"C"
*-05	7.85	15.00	9.00
-10	11.85	19.00	13.00
*-15	15.85	23.00	17.00
-20	19.85	27.00	21.00
*-25	23.85	31.00	25.00
-30	27.85	35.00	29.00
*-35	31.85	39.00	33.00
*-40	35.85	43.00	37.00

* NOT TOOLED

LEAD STYLE	"B"	AWG	TYPE
-01	TCF-3850-XX-01-TB-0315	38	COAX
*-02	GBTX-34100-01	34	TWINAX
*-03	CCS-158266-01-CC	32	POWER

* NOT TOOLED

F:\DWG\MISC_MKTG\FCF8-XX-XX-X-XX.XX-S-X-MT.SLDDRW

NOTES:

1. Ⓢ REPRESENTS A CRITICAL DIMENSION.
2. ALL ASSEMBLIES TO BE 100% ELECTRICALLY TESTED FOR SHORTS & OPENS.
3. ALL ASSEMBLIES TO BE 100% HI-POT TESTED AT 300V.
4. FOR SUB-ASSEMBLY AND FINISHED GOOD PACKAGING REQUIREMENTS, REFERENCE PACKAGING STANDARD CO-HD-WI-3033-M.
5. LABEL TO BE CENTERED ON CABLE ASSEMBLY AS SHOWN. LABEL TO CONTAIN: PART NUMBER, SHOP ORDER, & DATE CODE.
6. CABLE LENGTH GREATER THAN 40" [1016mm] IS A VALID PART NUMBER, BUT NOT SUPPORTED BY S.I. TEST DATA.
7. CABLES LESS THAN 5" [127.0mm] HAVE A LENGTH TOLERANCE OF +/- .050" [1.27mm].
8. DEFAULT SIGNAL MAPPING IS PIN 01 TO PIN N, OUTER GND POSITIONS ARE CONNECTED TO CONNECTOR SHELL AND WHEN APPLICABLE TO COAX AND TWINAX SHIELD. FOR PIN 01 TO PIN 01 SIGNAL MAPPING, SELECT WIRING OPTION -1.
9. NOTE DELETED.
10. ACTUATE LATCHES TO ENSURE THEY WILL DEFLECT FLUSH WITH PLASTIC AND RETURN TO DIM "C" POSITION.
11. SOLDER THESE 3 LOCATIONS AFTER SHIELD HAS BEEN FULLY SEATED.
12. MEASURE ACROSS SHIELDS AT A POINT CLOSEST TO THE END OF THE CABLE.

UNLESS OTHERWISE SPECIFIED,
DIMENSIONS ARE IN MILLIMETERS.
TOLERANCES ARE:
DECIMALS ANGLES
X.X: ±0.3 [01]
X.XX: ±0.13 [005]
X.XXX: ±0.051 [0020]

PROPRIETARY NOTE
THIS DOCUMENT CONTAINS CONFIDENTIAL AND PROPRIETARY INFORMATION AND ALL DESIGN, MANUFACTURING, REPRODUCTION, USE, PATENT RIGHTS AND SALES RIGHTS ARE EXPRESSLY RESERVED BY SAMTEC, INC. THIS DOCUMENT SHALL NOT BE DISCLOSED, IN WHOLE OR PART, TO ANY UNAUTHORIZED PERSON OR ENTITY NOR REPRODUCED, TRANSFERRED OR INCORPORATED IN ANY OTHER PROJECT IN ANY MANNER WITHOUT THE EXPRESS WRITTEN CONSENT OF SAMTEC, INC.

MATERIAL: DO NOT SCALE DRAWING SHEET SCALE: 2:1
OVERMOLD: LCP
TERMINAL: PHOS BRONZE
SHIELD: PHOS BRONZE

DESCRIPTION: FCF8 CABLE ASSEMBLY

DWG. NO. FCF8-XX-XX-X-XX.XX-S-X

BY: D.SCHMELZ 8/18/2011 SHEET 1 OF 2



520 PARK EAST BLVD, NEW ALBANY, IN 47150
PHONE: 812-944-6733 FAX: 812-948-5047
e-Mail: info@SAMTEC.com code: 55322

IN-PROCESS 3
 ADD SH69-XX-X AS SHOWN THEN SH70-XX-X, HAND SEATED
 (BOTH ENDS OF CABLE)

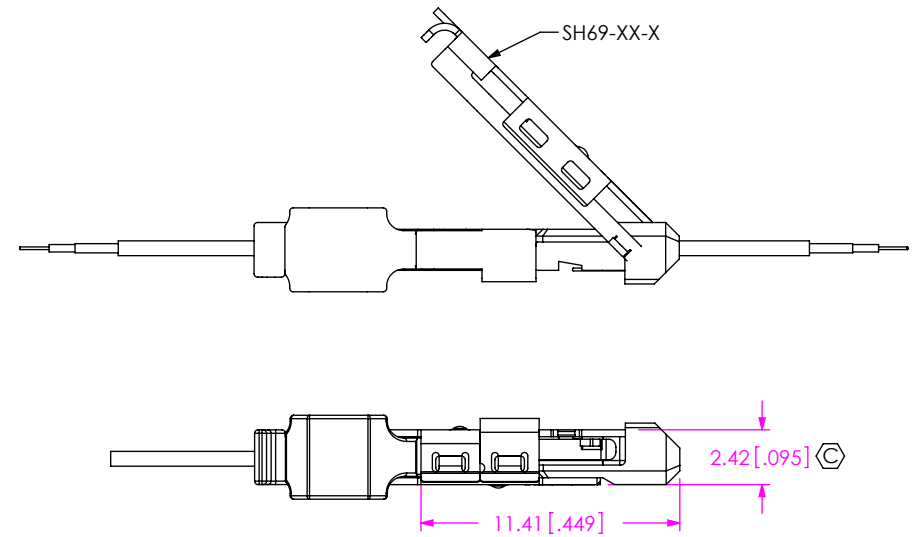

IN-PROCESS 1
 CUT & PREP CABLES

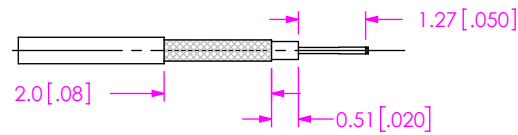

IN-PROCESS 2
 SOLDER CABLES TO SUB-FCF8-XX-X-S
 (BOTH ENDS OF CABLE)

SOLDER PER SAMTEC ACCEPTABILITY
 REQUIREMENTS: HDR-PI-01 "CABLE ASSEMBLY
 WORKMANSHIP STANDARDS".

SRP-065-005-01
 (PLACED ON TOP OF SHIELD,
 HIDDEN FOR CLARITY)

SUB-FCF8-XX-X-S

NO CABLES SOLDERED
 TO OUTSIDE 2 PINS

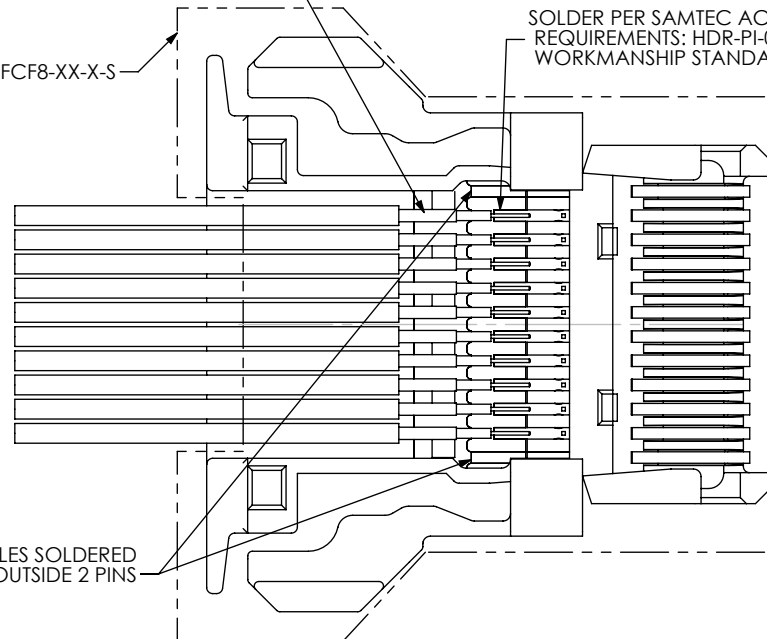

IN-PROCESS 4
 ADD SH70-XX-X, SEAT WITH PRESS

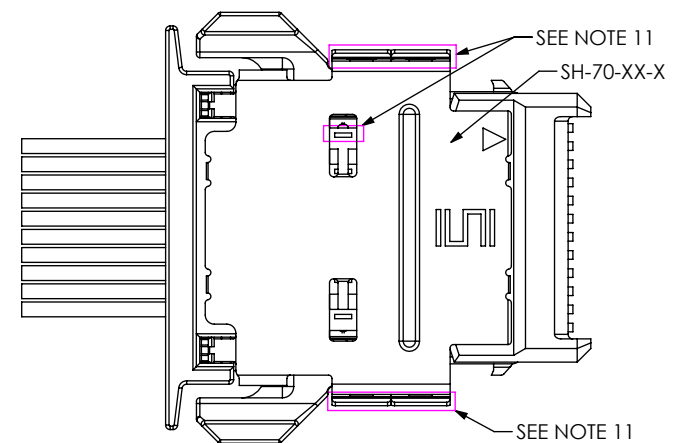

PROPRIETARY NOTE
 * THIS DOCUMENT CONTAINS CONFIDENTIAL AND
 PROPRIETARY INFORMATION AND ALL DESIGN,
 MANUFACTURING, REPRODUCTION, USE, PATENT RIGHTS
 AND SALES RIGHTS ARE EXPRESSLY RESERVED BY SAMTEC,
 INC. THIS DOCUMENT SHALL NOT BE DISCLOSED, IN WHOLE
 OR PART, TO ANY UNAUTHORIZED PERSON OR ENTITY NOR
 REPRODUCED, TRANSFERRED OR INCORPORATED IN ANY
 OTHER PROJECT IN ANY MANNER WITHOUT THE EXPRESS
 WRITTEN CONSENT OF SAMTEC, INC.

DO NOT SCALE DRAWING

SHEET SCALE: 3:1

samtec

520 PARK EAST BLVD, NEW ALBANY, IN 47150
 PHONE: 812-944-6733 FAX: 812-948-5047
 e-Mail: info@SAMTEC.com code: 55322

DESCRIPTION: FCF8 CABLE ASSEMBLY

DWG. NO. FCF8-XX-XX-X-XX.XX-S-X

BY: D.SCHMELZ 8/18/2011 SHEET 2 OF 2