

THIS DRAWING IS UNPUBLISHED. RELEASED FOR PUBLICATION 20
 © COPYRIGHT 20 BY - ALL RIGHTS RESERVED.

LOC DW DIST

REVISIONS

P	LTR	DESCRIPTION	DATE	DWN	APVD
A		RELEASED	11OCT2013	W.C	V.P
A1		REVISED(ECR-14-005112)	31MAR2014	W.C	V.P

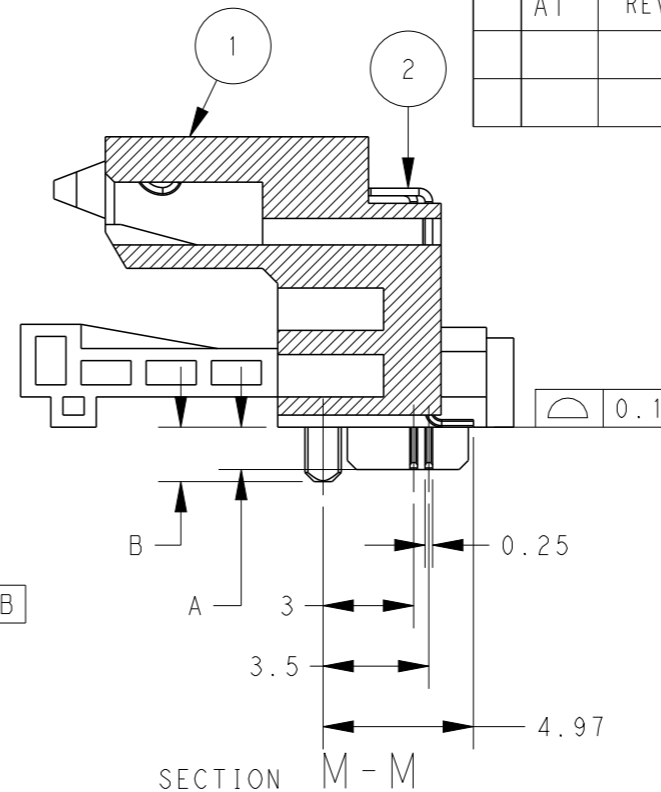
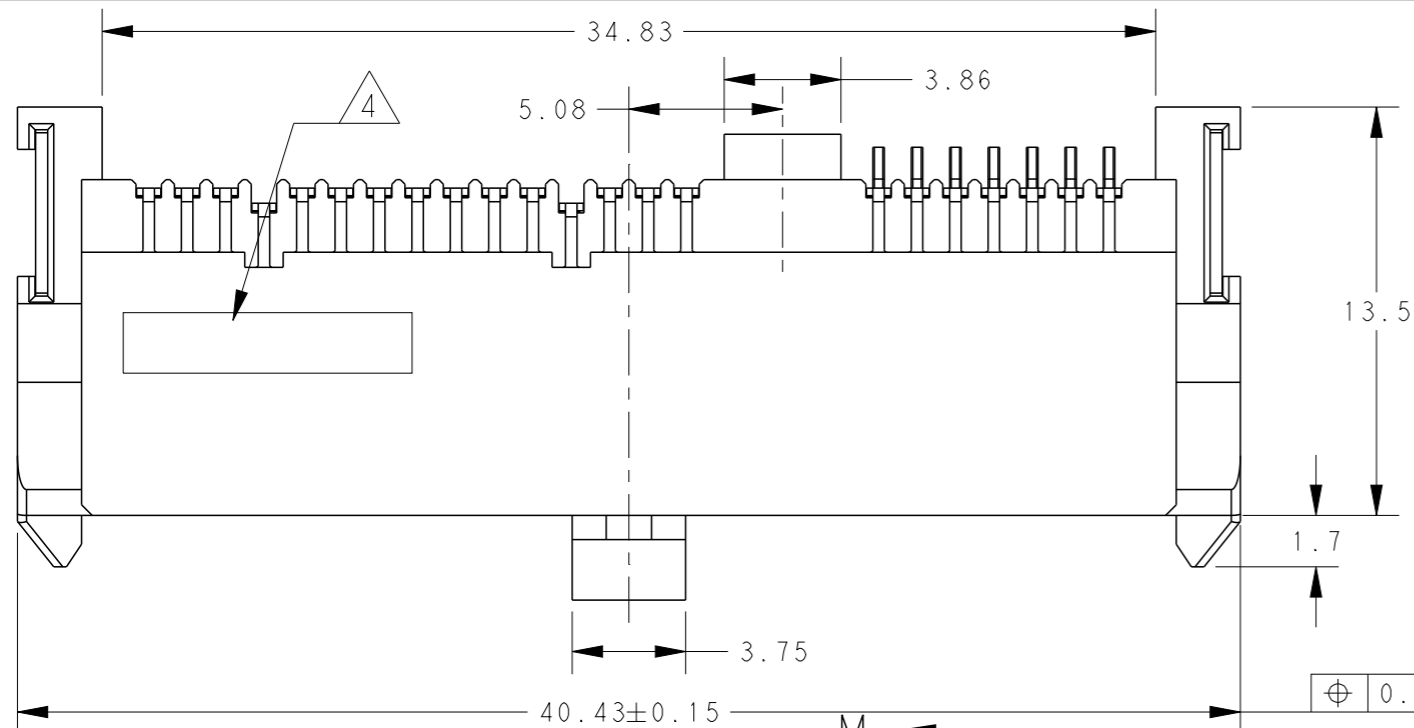

- MATERIAL
 - ① HOUSING: HIGH TEMPERATURE THERMOPLASTIC UL94V-0, COLOR: BLACK
 - ② CONTACT: COPPER ALLOY
 - ③ LEG: COPPER ALLOY
 - ④ CAP: HIGH TEMPERATURE THERMOPLASTIC UL94V-0, COLOR: BLACK

- FINISH:
 - CONTACT: CONTACT AREA: AU PLATING 0.127um WITH LUBRICANT HM-15
 - MATTE-TIN PLATING 2.5um ON SOLDER TAILS
 - NICKEL UNDER PLATING 1.3um OVER ALL.
 - SOLDER LEG: MATTE-TIN PLATING 2.5um
 - NICKEL UNDER PLATING 1.3um OVER ALL.

- MEET HALOGEN FREE REQUIREMENT:
 - Cl: 900 ppm MAX.
 - Br: 900 ppm MAX.
 - Cl+Br: 1500 Max.

DATE CODE
 YY WW D S
 ASSY MECHINE ID
 DAY OF WEEK
 WEEK OF YEAR
 THE LAST DIGITS OF YEAR

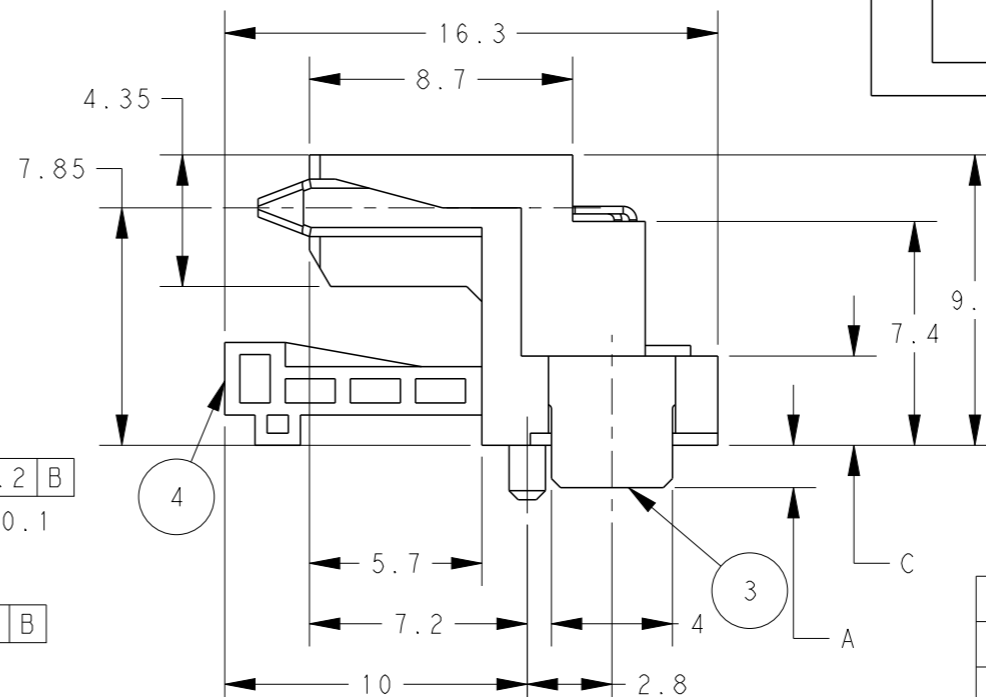
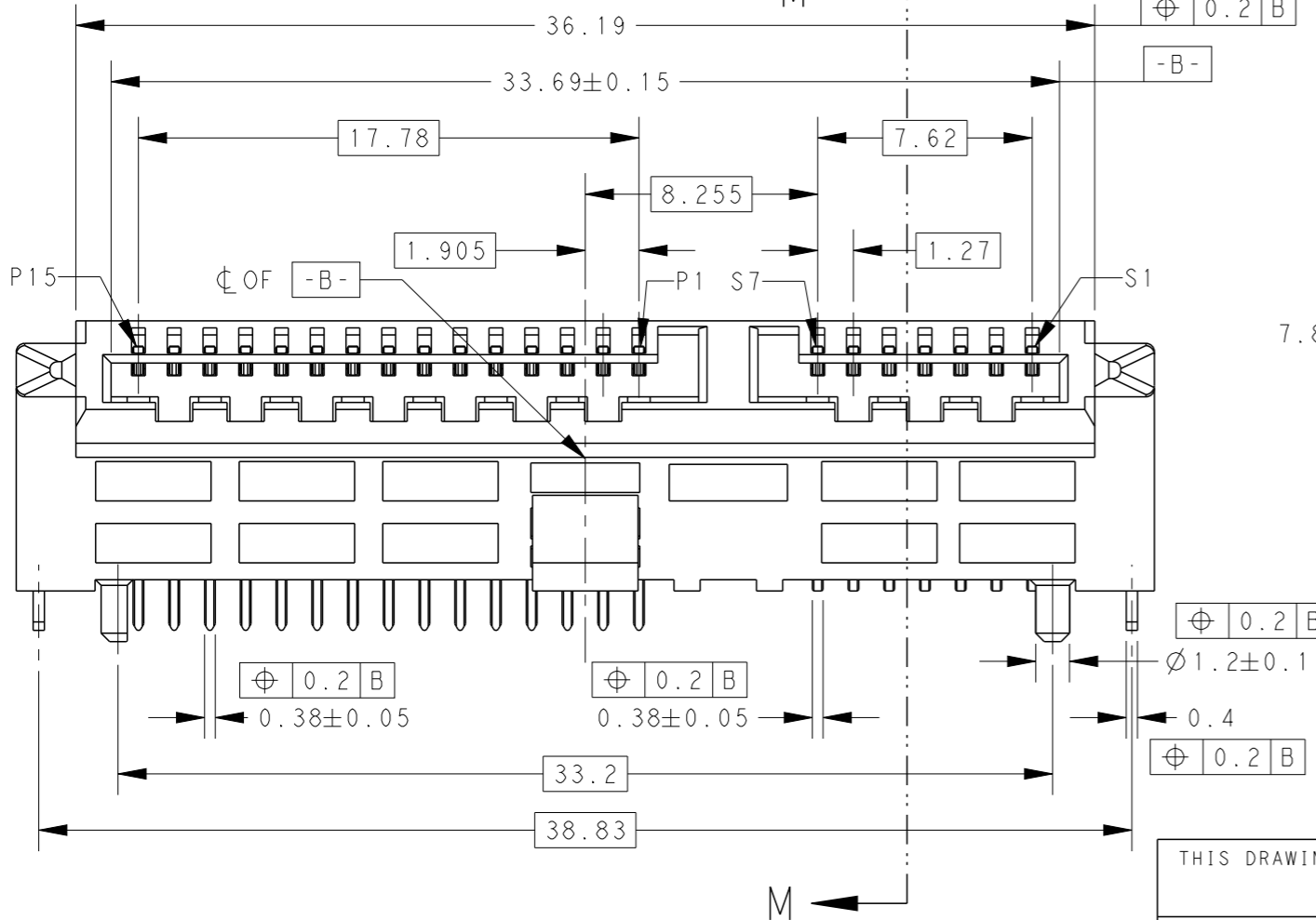

3.65	0.9	0.7	2129571-2
2.95	1.8	1.4	2129571-1
DIM.C	DIM.B	DIM.A	PART NUMBER

THIS DRAWING IS A CONTROLLED DOCUMENT.

DIMENSIONS:	TOLERANCES UNLESS OTHERWISE SPECIFIED:
mm	
	0 PLC ±0.2
	1 PLC ±0.2
	2 PLC ±0.2
	3 PLC ±0.2
	4 PLC ±0.2
	ANGLES ±5
MATERIAL	FINISH
①	②

DWN	W.CHEN	31OCT12
CHK	V.PENG	31OCT12
APVD	H.KODAMA	31OCT12
PRODUCT SPEC	108-99048	
APPLICATION SPEC	501-99048	
WEIGHT		
CUSTOMER DRAWING		

STE TE Connectivity

REC. ASSEMBLY
 SLANT INSERTION SATA H7.85
 6.0 GBPS

SIZE	CAGE CODE	DRAWING NO	RESTRICTED TO
A3	00779	C-2129571	-

SCALE 4:1 SHEET 1 OF 3 REV A1

P	LTR	DESCRIPTION	DATE	DWN	APVD
-	-	SEE SHEET 1	-	-	-

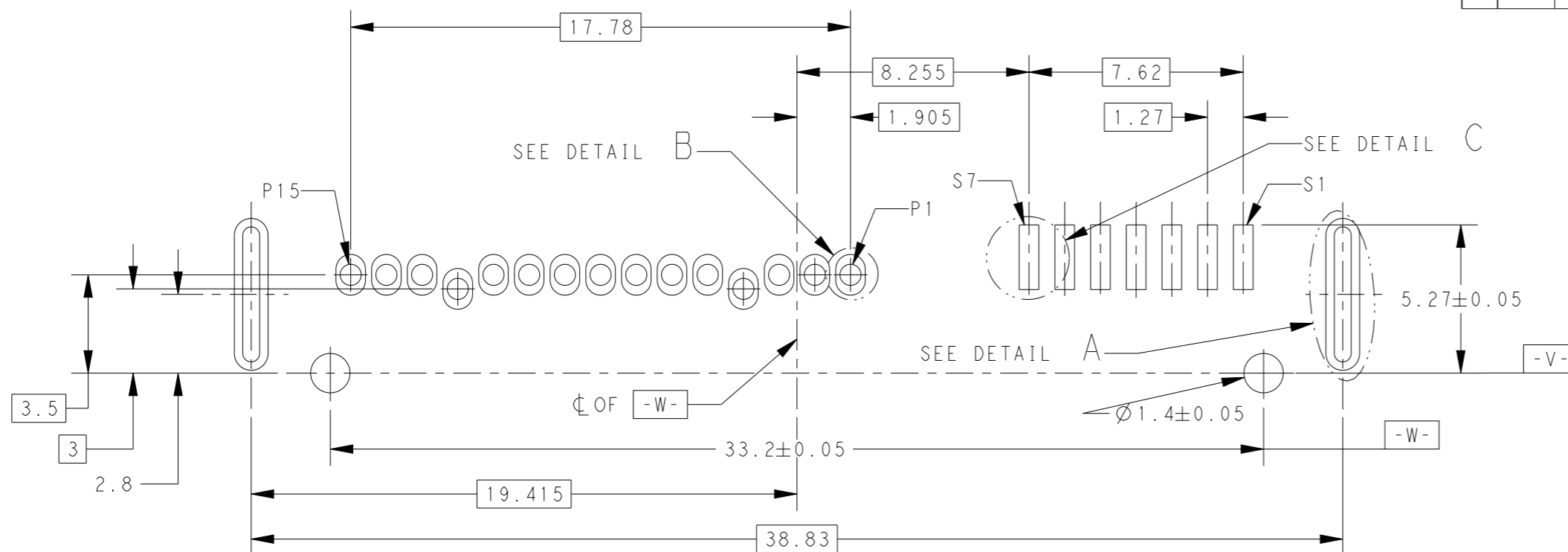

REFERENCE PCB LAYOUT
 REFERENCE PCB THICKNESS T=1.0
 SCALE 5:1

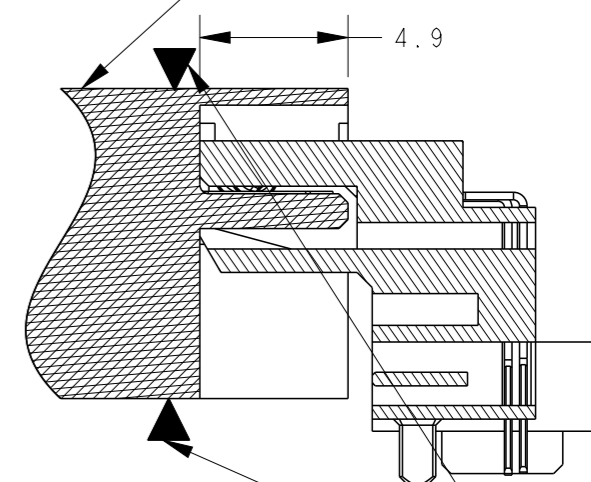
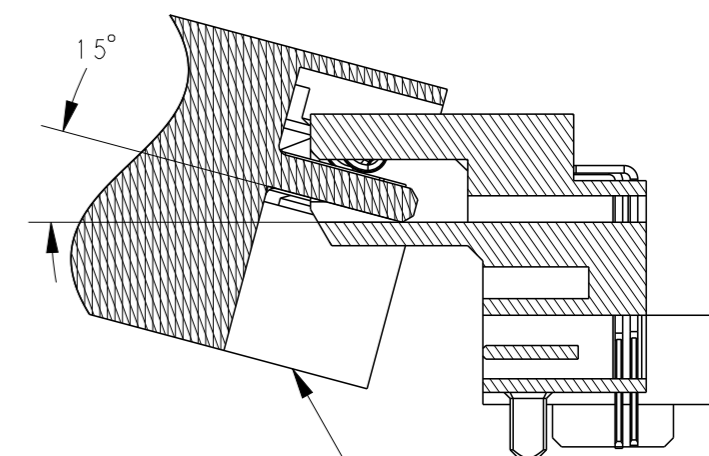

SUGGEST TO ADD SUPPORTS ON THE
 HDD NEAR THE CONNECTORS

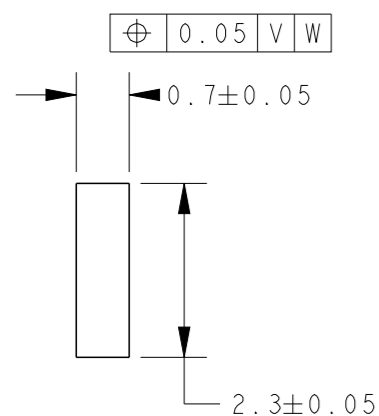

DETAIL C
 SCALE 10:1

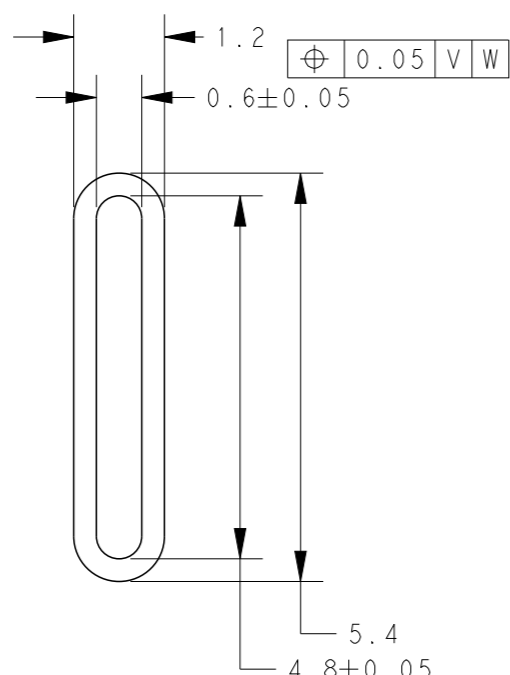

DETAIL A
 SCALE 10:1

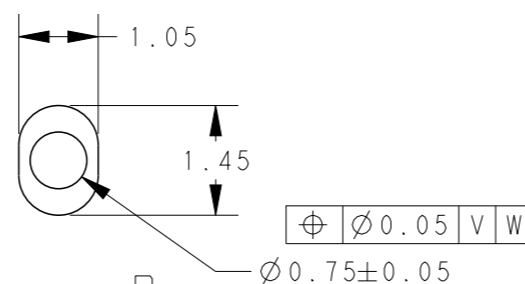

DETAIL B
 SCALE 10:1

THIS DRAWING IS A CONTROLLED DOCUMENT.

DIMENSIONS:
 mm

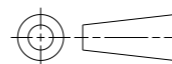

MATERIAL

TOLERANCES UNLESS OTHERWISE SPECIFIED:
 0 PLC ±0.2
 1 PLC ±0.2
 2 PLC ±0.2
 3 PLC ±0.2
 4 PLC ±0.2
 ANGLES ±5
 FINISH

DWN	-
CHK	-
APVD	-
PRODUCT SPEC	-
APPLICATION SPEC	-
WEIGHT	-
CUSTOMER DRAWING	-

STE TE Connectivity

NAME: REC. ASSEMBLY
 SLANT INSERTION SATA H7.85
 6.0 GBPS

SIZE	CAGE CODE	DRAWING NO	RESTRICTED TO
A3	00779	C-2129571	-

SCALE 4:1 SHEET 2 OF 3 REV A1

THIS DRAWING IS UNPUBLISHED. RELEASED FOR PUBLICATION 20
 © COPYRIGHT 20 BY - ALL RIGHTS RESERVED.

LOC	DIST	REVISIONS			
P	LTR	DESCRIPTION	DATE	DWN	APVD
DW		SEE SHEET 1	-	-	-

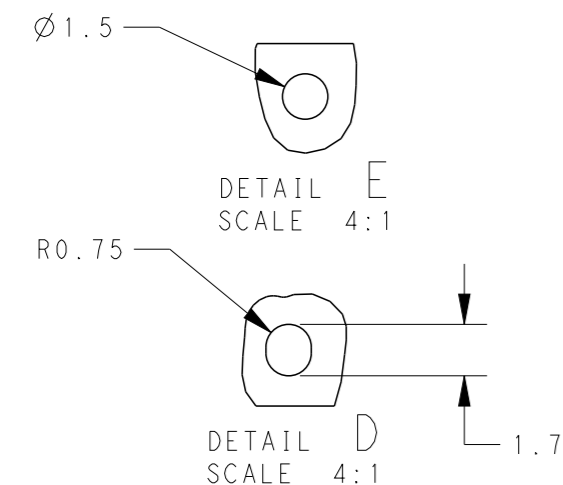
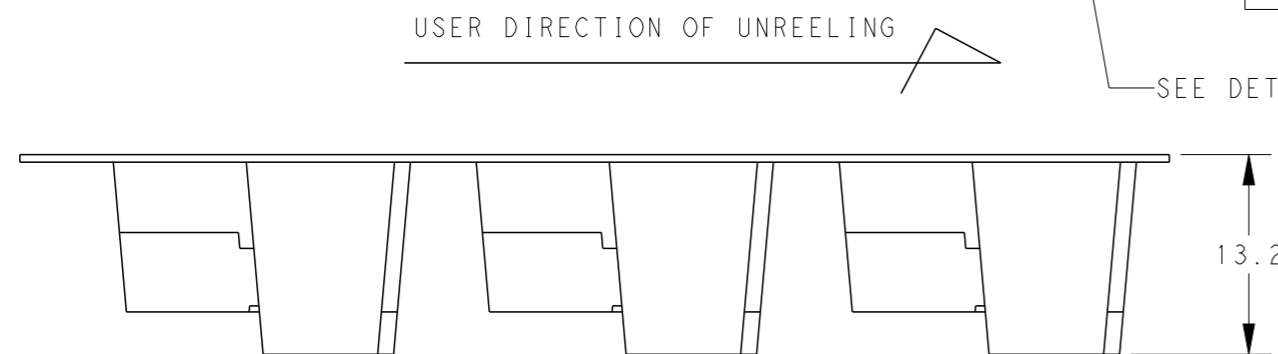
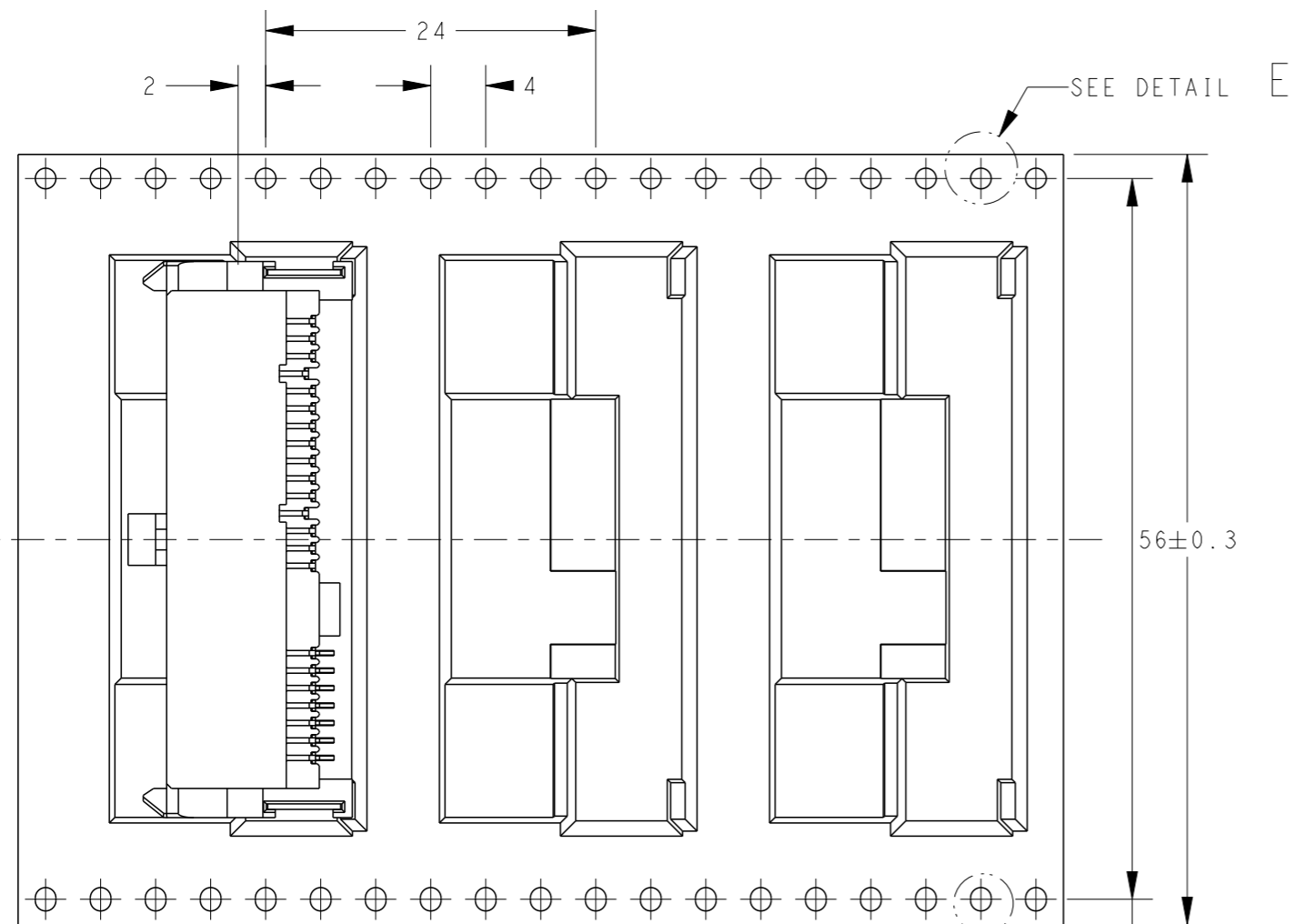

- △ PEELING STRENGTH OF COVER TAPE: 0.2N~1.2N
- 6. PACKING MATERIAL: CARRY TAPE: PS, COLOR: CLEAR
COVER TAPE: PET, COLOR: CLEAR
- 7. QUANTITY: 280PCS/ REEL
840PCS/ BOX

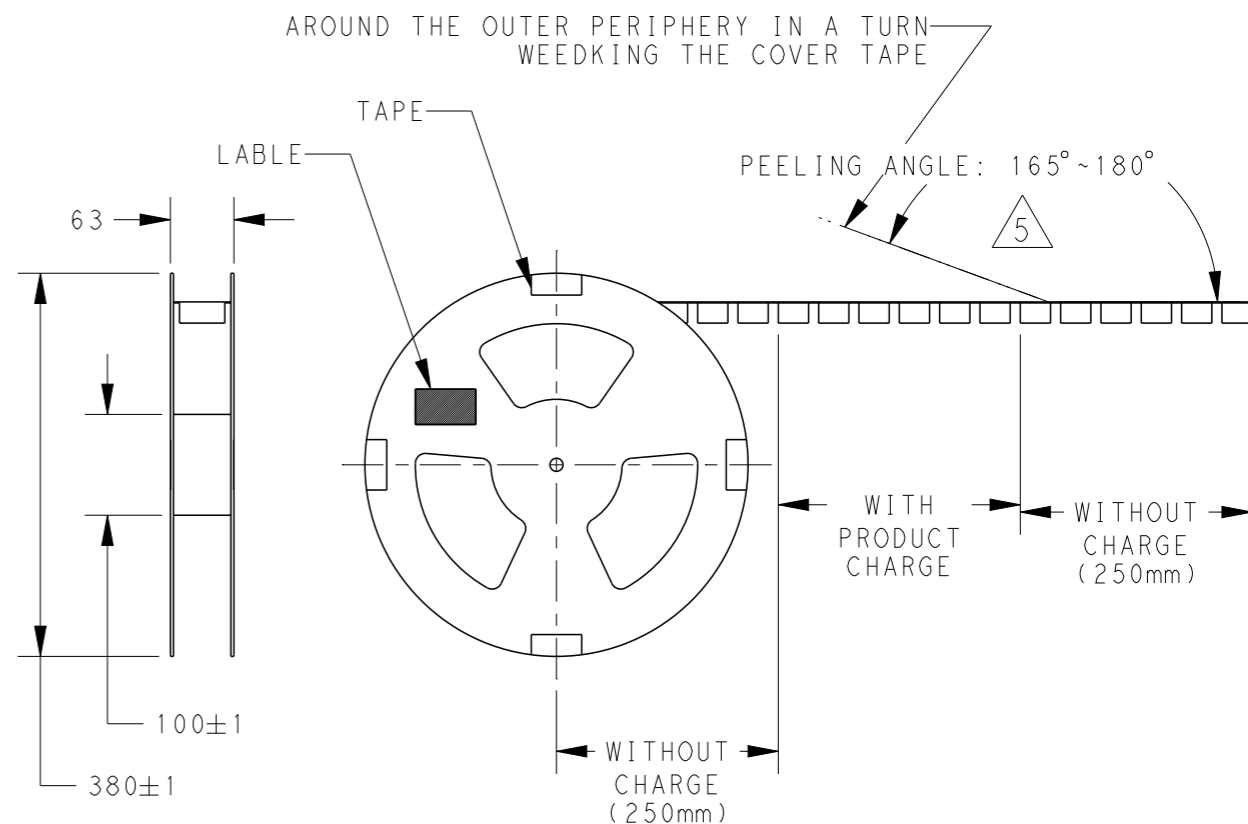

THIS DRAWING IS A CONTROLLED DOCUMENT.		DWN	-	STE TE Connectivity	
DIMENSIONS: mm		CHK	-		
TOLERANCES UNLESS OTHERWISE SPECIFIED:		APVD	-	NAME	
0 PLC ±0.2		PRODUCT SPEC	-	REC. ASSEMBLY	
1 PLC ±0.2		APPLICATION SPEC	-	SLANT INSERTION SATA H7.85	
2 PLC ±0.2		WEIGHT	-	SIZE	A3
3 PLC ±0.2		CUSTOMER DRAWING	-	CAGE CODE	00779
4 PLC ±0.2				DRAWING NO	C-2129571
ANGLES ±5				RESTRICTED TO	-
FINISH -				SCALE	N/A
				SHEET	3 OF 3
				REV	A1