



Feature:

- 50A Switching Capability
- 125°C High Operating Temperature
- 1 Form A and 1 Form C contact available
- Dustproof and Fluxproof type available
- Resistor or diode paralleled type available

Contact Load

Model	SARN
Nominal Load (Res. Load)	Normal: NO:50A 14VDC /NC: 30A 14VDC (at 23°C) NO:40A 14VDC /NC: 20A 14VDC (at 85°C)
	Special: 2A : NO:30A 14VDC
Max. Switching Current (normal)	On(NO):150A (Surge Current of Lamp Load , 14VDC) Off(NO):50A (Resistive Load ,14VDC)

Contact Data

Contact Voltage	Load Type		Contact Current		Duty Factor	Endurance (Cycles)	Contact Material
			Form C	Form A			
14VDC	Res.	on	50	30	50	1x10 ⁵	AgSnO ₂
		off	50	30	50		
	Motor	on	80 ^a	--	80 ^a	1x10 ⁵	AgSnO ₂
		off	30	--	30		
	Lamp	on	150 ^a	--	150 ^a	1x10 ⁵	AgSnO ₂
		off	30	--	30		
27VDC	Res.	on	30	10	20	1x10 ⁵	AgSnO ₂
		off	30	10	20		

a. Time ratio of peak current: Stable current is: 1:10

Load Wiring Diagram

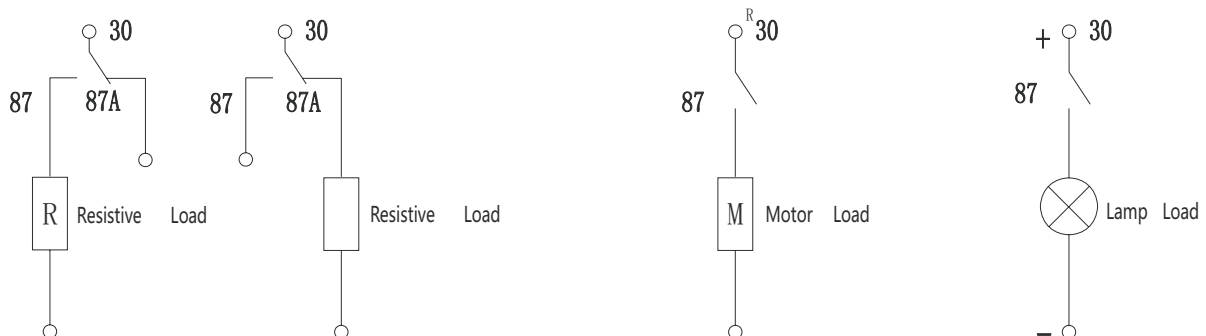

Characteristic Data

Contact Material	SilverAlloy
Dropping Voltageof Contacts	200mv/at 10A (max)
Operate Time	10msec.Max.
Release Time	ordinary type:10msec.Max. with resistor or diode type :15 msec. Max.
Initial Insulation Resistance	100MΩ Min.(DC500V)
Initial Dielectric Strength	OP/OP : AC500V , 50/60Hzfor 1min.
	IP/OP : AC500V , 50/60Hzfor 1min.
Vibration Resistance	5 ~ 22.3Hz at double amplitude of 10 mm 22.3~500Hz 98m/s ²
Shock Resistance	NO 30G/NC 5G
Collision Response acceleration(T/TC Type)	The relay will respond when acceleration is > 30g 11msec. The relay will not respond when acceleration is <10g 11msec.
Endurance (operations)	Mechanical (10,800ops./h) 1x10 ⁷ cycles
	Electrical (900ops./h) See the contact parameters table
Ambient Temperature	-40°C ~ +125°C(nocondensation)
Unit Weight	Approx. 32.0g

Coil Data(at 20°C)

Nominal Voltage (VDC)	Nominal Operating Current 10%(mA)	Coil Resistance ± 10%(Ω)	Parallel Resistance (Ω)	Equivalent Resistance (Ω)	Max. allowable Voltage	Pick-up Voltage (Max.)	Drop-out Voltage (Min.)	Coil Power (W)
12	133.33	90	---	---	150%of Nominal Voltage	60%of Nominal Voltage	10%of Nominal Voltage	Approx.1.6
12	133.33	90	680	80				Approx.1.8
24	66.7	360	---	---				Approx.1.6
24	66.7	360	2700	320				Approx.1.8

Ordering Information

Nomenclature										
SARN	-S	-1	12	D	M	F	T	R	-XX	
Special Parameter : Nil-Standard type , 01-terminal without hole										
Accessory Form:Nil-withoutaccessory,R-withresistor D-withdiode(see wiring diagram) DC-withdiode(see wiring diagram)										
Structure type: Nil-Standard type,T-Collision Response type TC-Collision Response type(see wiring diagram)										
Mounting type : Nil-without bracket , F-with iron bracket , P-PCB type										
Contact Form: Nil-FormC,M-FormA,										
Coil Power: D-1.6/1.8W										
Coil Voltage (VDC): 12, 24										
Number of Poles: 1-1Pole, 2-2Pole										
ProtectiveConstruction:Nil-Dustproof,-S Fluxproof										
Type Designation: SARN										

OutlineDimensions

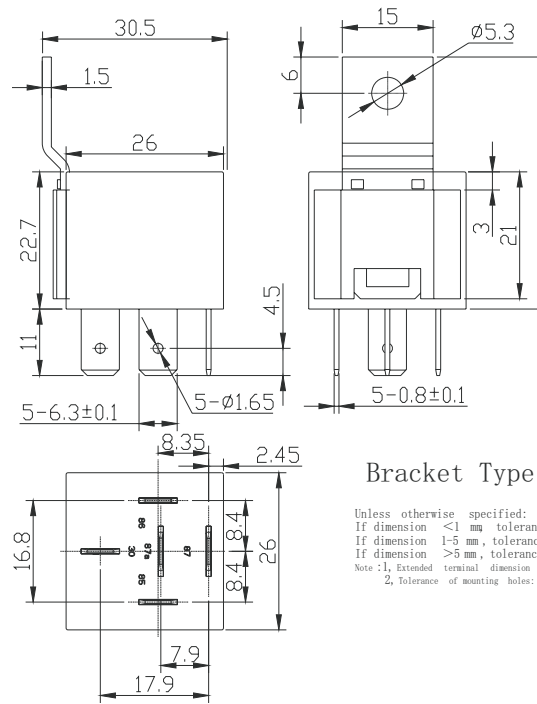
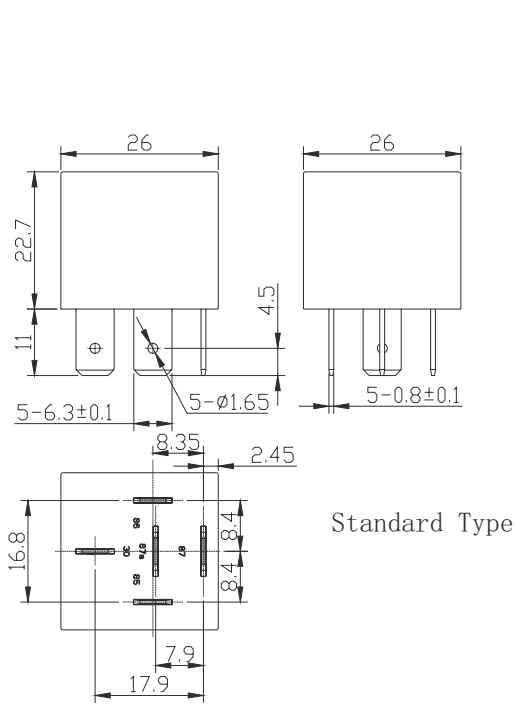

Unless otherwise specified:
 If dimension < 1 mm, tolerance : 0.2 mm
 If dimension 1-5 mm, tolerance : 0.3 mm
 If dimension > 5 mm, tolerance : 0.4 mm
 Note : 1, Extended terminal dimension is dimension before soldering .
 2, Tolerance of mounting holes : 0.1mm

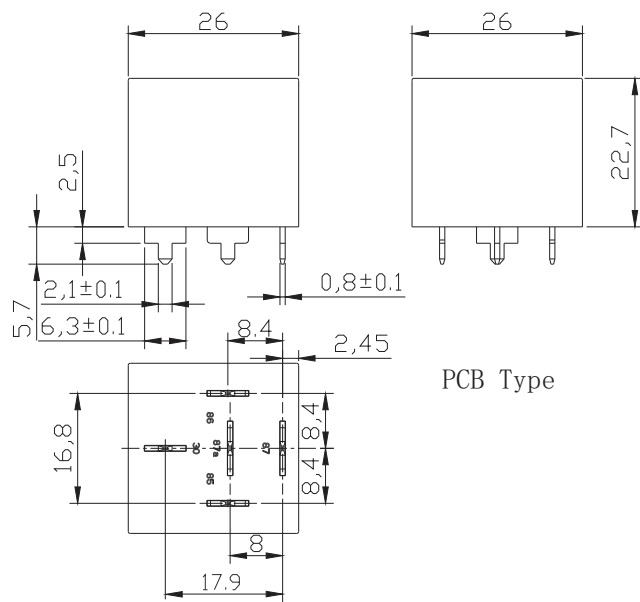

未标注尺寸公差：
 < 1mm: ±0.2mm
 1~5mm: ±0.3mm
 > 5mm: ±0.4mm
 注：1、引出脚尺寸为预焊前尺寸
 2、安装孔尺寸公差： 0.1±mm

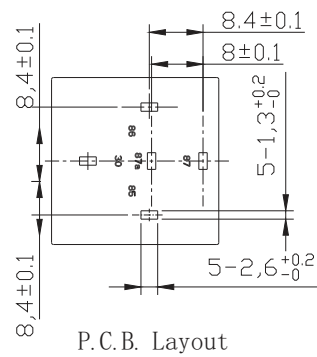

Wiring Diagram

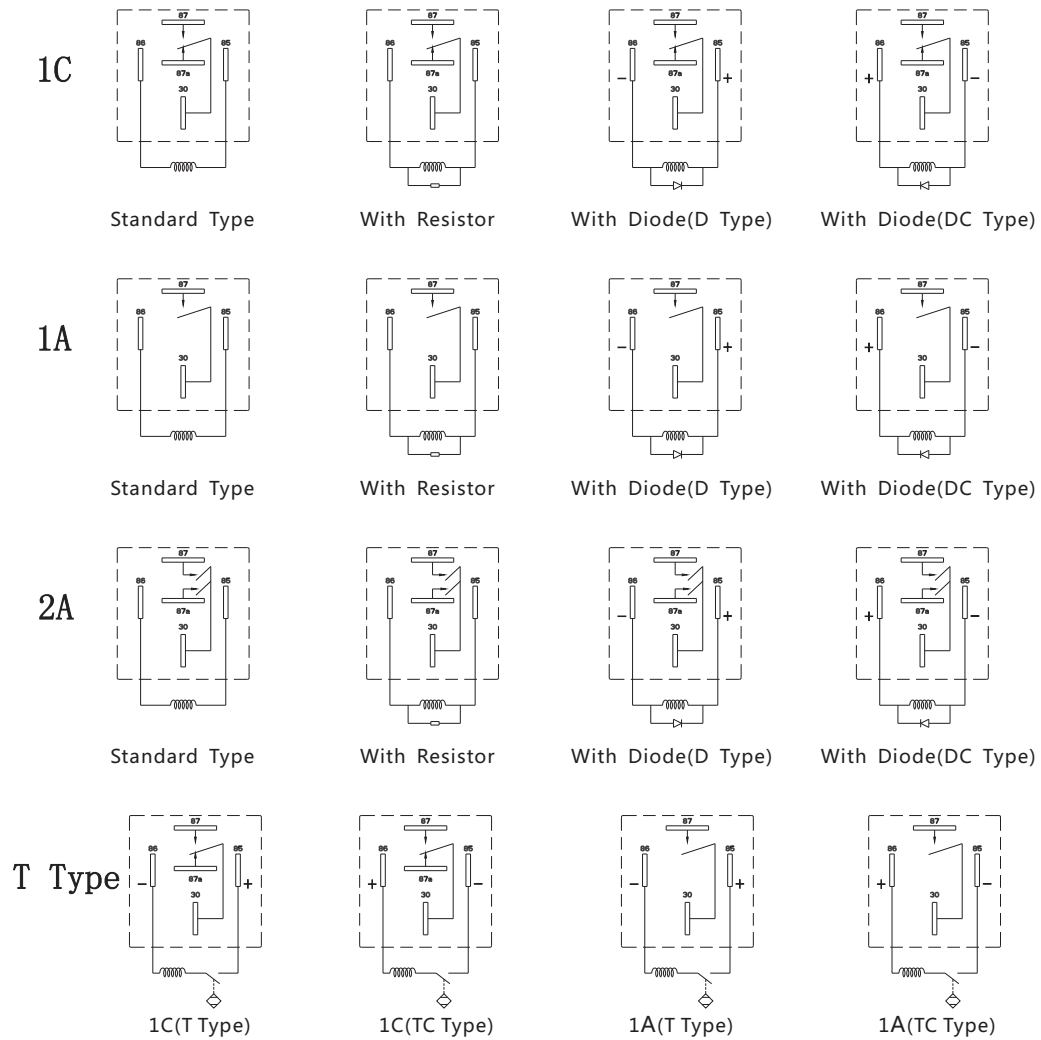

Typical Applications

- rear window defogger, battery breaking device, automotive AC foglight control, headlight control
- electric power distributor, ABS traction control system.

Characteristic Curves

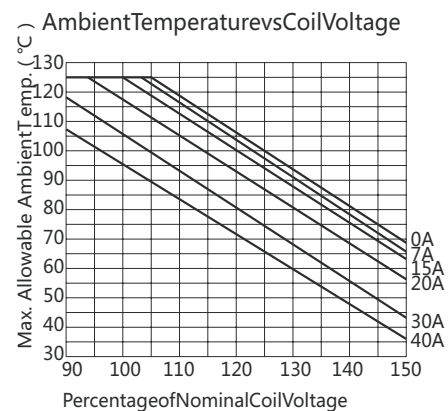
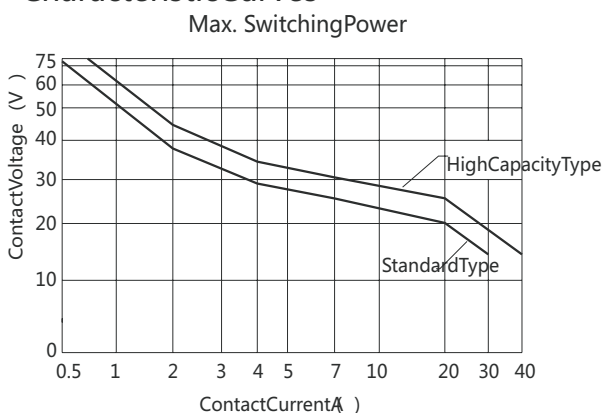

Disclaimer :

This datasheet is the customers' reference. All the specifications are subject to change without notice. We could not evaluate all the performance and parameters for every possible application. Thus the users should be in a right position to choose the suitable product for their own application. If there is any query, please contact Sanyo for technical service. However, it is the users' responsibility to determine which products should be used only.

© Sanyo Corporation Limited, All rights of Sanyo to reserved