



Is Now Part of



ON Semiconductor®

To learn more about ON Semiconductor, please visit our website at
www.onsemi.com

Please note: As part of the Fairchild Semiconductor integration, some of the Fairchild orderable part numbers will need to change in order to meet ON Semiconductor's system requirements. Since the ON Semiconductor product management systems do not have the ability to manage part nomenclature that utilizes an underscore (_), the underscore (_) in the Fairchild part numbers will be changed to a dash (-). This document may contain device numbers with an underscore (_). Please check the ON Semiconductor website to verify the updated device numbers. The most current and up-to-date ordering information can be found at www.onsemi.com. Please email any questions regarding the system integration to Fairchild_questions@onsemi.com.

ON Semiconductor and the ON Semiconductor logo are trademarks of Semiconductor Components Industries, LLC dba ON Semiconductor or its subsidiaries in the United States and/or other countries. ON Semiconductor owns the rights to a number of patents, trademarks, copyrights, trade secrets, and other intellectual property. A listing of ON Semiconductor's product/patent coverage may be accessed at www.onsemi.com/site/pdf/Patent-Marking.pdf. ON Semiconductor reserves the right to make changes without further notice to any products herein. ON Semiconductor makes no warranty, representation or guarantee regarding the suitability of its products for any particular purpose, nor does ON Semiconductor assume any liability arising out of the application or use of any product or circuit, and specifically disclaims any and all liability, including without limitation special, consequential or incidental damages. Buyer is responsible for its products and applications using ON Semiconductor products, including compliance with all laws, regulations and safety requirements or standards, regardless of any support or applications information provided by ON Semiconductor. "Typical" parameters which may be provided in ON Semiconductor data sheets and/or specifications can and do vary in different applications and actual performance may vary over time. All operating parameters, including "Typicals" must be validated for each customer application by customer's technical experts. ON Semiconductor does not convey any license under its patent rights nor the rights of others. ON Semiconductor products are not designed, intended, or authorized for use as a critical component in life support systems or any FDA Class 3 medical devices or medical devices with a same or similar classification in a foreign jurisdiction or any devices intended for implantation in the human body. Should Buyer purchase or use ON Semiconductor products for any such unintended or unauthorized application, Buyer shall indemnify and hold ON Semiconductor and its officers, employees, subsidiaries, affiliates, and distributors harmless against all claims, costs, damages, and expenses, and reasonable attorney fees arising out of, directly or indirectly, any claim of personal injury or death associated with such unintended or unauthorized use, even if such claim alleges that ON Semiconductor was negligent regarding the design or manufacture of the part. ON Semiconductor is an Equal Opportunity/Affirmative Action Employer. This literature is subject to all applicable copyright laws and is not for resale in any manner.



June 2014

74LVX08

Low Voltage Quad 2-Input AND Gate

Features

- Input Voltage Level Translation from 5 V to 3 V
- Ideal for Low-power / Low-Noise 3.3 V Applications
- Guaranteed Simultaneous Switching Noise Level and Dynamic threshold Performance

Description

The LVX08 contains four 2-input AND gates. The inputs tolerate voltages up to 7 V allowing the interface of 5 V systems to 3 V systems.

Ordering Information

Part Number	Top Mark	Package	Packing Method	Packing Description
74LVX08M	LVX08	SOIC 14L	Rail	14-Lead Small Outline Integrated Circuit, JEDEC MS-012, 0.150 inch Narrow
74LVX08MX	LVX08	SOIC 14L	Tape and Reel	14-Lead Small Outline Integrated Circuit, JEDEC MS-012, 0.150 inch Narrow
74LVX08MTCX	LVX08	TSSOP 14L	Tape and Reel	14-Lead Thin Shrink Small Outline Package, JEDEC MO-153, 4.4 mm Wide

All packages are lead free per JEDEC: J-STD-020B standard.

Connection Diagram

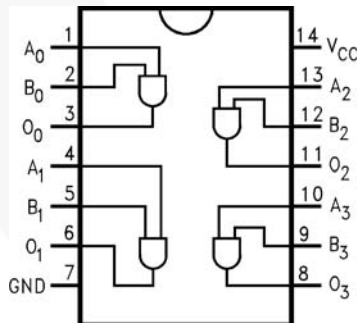

Logic Symbol

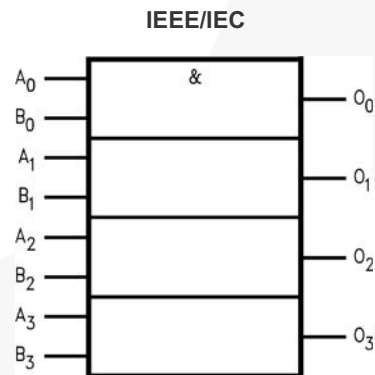

Pin Description

Pin Names	Description
A_n, B_n	Inputs
O_n	Outputs

Absolute Maximum Ratings

Stresses exceeding the absolute maximum ratings may damage the device. The device may not function or be operable above the recommended operating conditions and stressing the parts to these levels is not recommended. In addition, extended exposure to stresses above the recommended operating conditions may affect device reliability. The absolute maximum ratings are stress ratings only.

Symbol	Parameter	Rating	
V_{CC}	Supply Voltage	-0.5 V to 7.0 V	
I_{IK}	DC Input Diode Current, $V_I = -0.5$ V	-20 mA	
V_I	DC Input Voltage	-0.5 V to 7.0 V	
I_{OK}	DC Output Diode Current	$V_O = -0.5$ V	-20 mA
		$V_O = V_{CC} + 0.5$ V	+20 mA
V_O	DC Output Voltage	-0.5 V to $V_{CC} + 0.5$ V	
I_O	DC Output Source or Sink Current	± 25 mA	
I_{CC} or I_{GND}	DC V_{CC} or Ground Current	± 50 mA	
T_{STG}	Storage Temperature	-65°C to 150°C	
P	Power Dissipation	180 mW	
T_L	Lead Temperature (Soldering, 10 seconds)	240°C	

Recommended Operating Conditions⁽¹⁾

The Recommended Operating Conditions table defines the conditions for actual device operation. Recommended operating conditions are specified to ensure optimal performance to the datasheet specifications. Fairchild does not recommend exceeding them or designing to absolute maximum ratings.

Symbol	Parameter	Rating
V_{CC}	Supply Voltage	2.0 V to 3.6 V
V_I	Input Voltage	0 V to 5.5 V
V_O	Output Voltage	0 V to V_{CC}
T_A	Operating Temperature	-40°C to 85°C
$\Delta t / \Delta V$	Input Rise and Fall Time	0 ns/V to 100 ns/V

Note:

- Unused inputs must be held HIGH or LOW. They may not float.

DC Electrical Characteristics

Symbol	Parameter	V _{CC}	Conditions	T _A = 25°C			T _A = -40°C to +85°C		Unit
				Min.	Typ.	Max.	Min.	Max.	
V _{IH}	HIGH Level Input Voltage	2.0		1.5			1.5		V
		3.0		2.0			2.0		
		3.6		2.4			2.4		
V _{IL}	LOW Level Input Voltage	2.0				0.5		0.5	V
		3.0				0.8		0.8	
		3.6				0.8		0.8	
V _{OH}	HIGH Level Output Voltage	2.0	V _{IN} = V _{IL} or V _{IH} , I _{OH} = -50 μA	1.9	2.0		1.9		V
		3.0	V _{IN} = V _{IL} or V _{IH} , I _{OH} = -50 μA	2.9	3.0		2.9		
			V _{IN} = V _{IL} or V _{IH} , I _{OH} = -4 mA	2.58			2.48		
V _{OL}	LOW Level Output Voltage	2.0	V _{IN} = V _{IL} or V _{IH} , I _{OL} = -50 μA		0.0	0.1		0.1	V
		3.0	V _{IN} = V _{IL} or V _{IH} , I _{OL} = -50 μA		0.0	0.1		0.1	
			V _{IN} = V _{IL} or V _{IH} , I _{OL} = -4 mA			0.36		0.44	
I _{IN}	Input Leakage Current	3.6	V _{IN} = 5.5 V or GND			±0.1		±1.0	μA
I _{CC}	Quiescent Supply Current	3.6	V _{IN} = V _{CC} or GND			2.0		20.0	μA

Noise Characteristics⁽²⁾

Symbol	Parameter	V _{CC} (V)	C _L (pF)	T _A = 25°C		Unit
				Typ.	Limit	
V _{OLP}	Quiet Output Maximum Dynamic V _{OL}	3.3	50	0.3	0.5	V
V _{OLV}	Quiet Output Minimum Dynamic V _{OL}	3.3	50	-0.3	-0.5	V
V _{IHD}	Minimum HIGH Level Dynamic Input Voltage	3.3	50		2.0	V
V _{ILD}	Maximum LOW Level Dynamic Input Voltage	3.3	50		0.8	V

Note:2. Input t_r = t_f = 3 ns

AC Electrical Characteristics

Symbol	Parameter	V _{CC} (V)	C _L (pF)	T _A = 25°C			T _A = -40°C to +85°C		Unit
				Min.	Typ.	Max.	Min.	Max.	
t _{PLH} , t _{PHL}	Propagation Delay Time	2.7	15		6.3	11.4	1.0	13.5	ns
			50		8.8	14.9	1.0	17.0	
		3.3 ± 0.3	15		4.8	7.1	1.0	8.5	
			50		7.3	10.6	1.0	12.0	
t _{OSLH} , t _{OSHL}	Output to Output Skew ⁽³⁾	2.7	50			1.5		1.5	ns
		3.3				1.5		1.5	

Note:

3. Parameter guaranteed by design $t_{OSLH} = |t_{PLHm} - t_{PLHn}|$, $t_{OSHL} = |t_{PHLm} - t_{PHLn}|$.

Capacitance

Symbol	Parameter	T _A = 25°C			T _A = -40°C to +85°C		Unit
		Min.	Typ.	Max.	Min.	Max.	
C _{IN}	Input Capacitance		4	10		10	pF
C _{PD}	Power Dissipation Capacitance ⁽⁴⁾		18				pF

Note:

4. C_{PD} is defined as the value of the internal equivalent capacitance which is calculated from the operating current consumption without load.

Average operating current can be obtained by the equation: $I_{CC(opr.)} = \frac{C_{PD} \times V_{CC} \times f_{IN} \times I_{CC}}{4 \text{ (per Gate)}}$

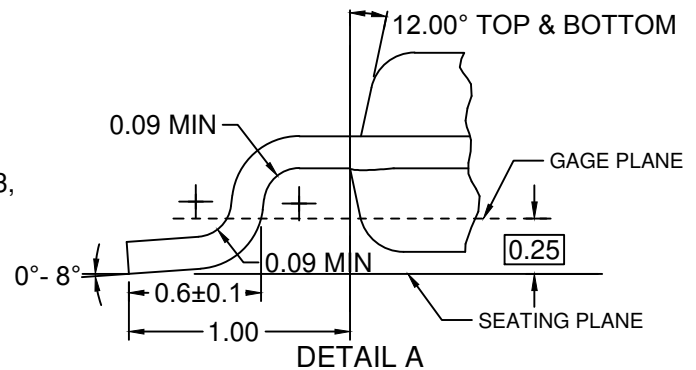
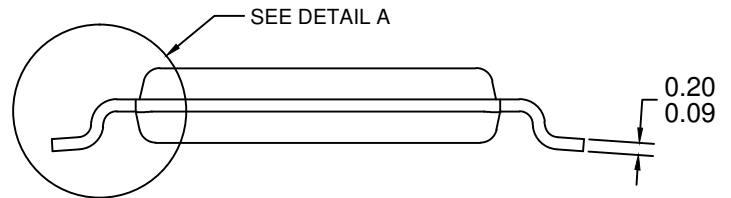
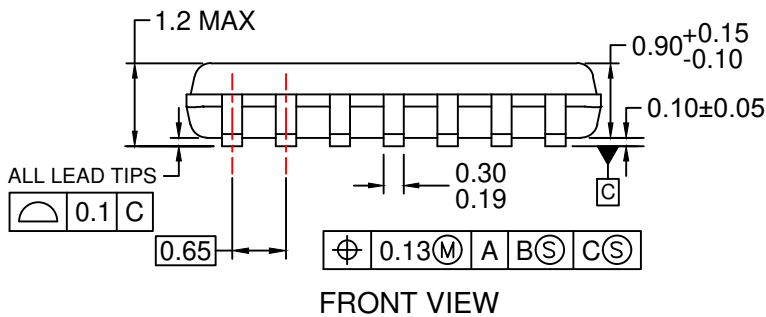
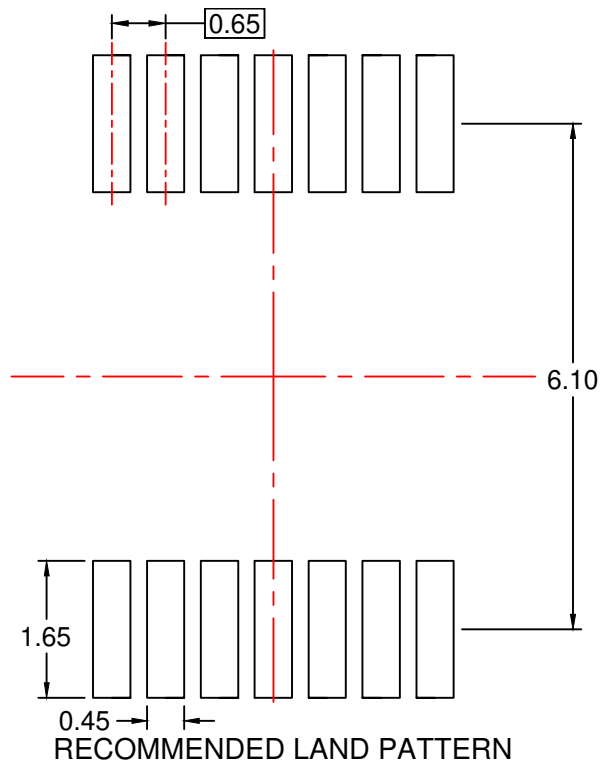
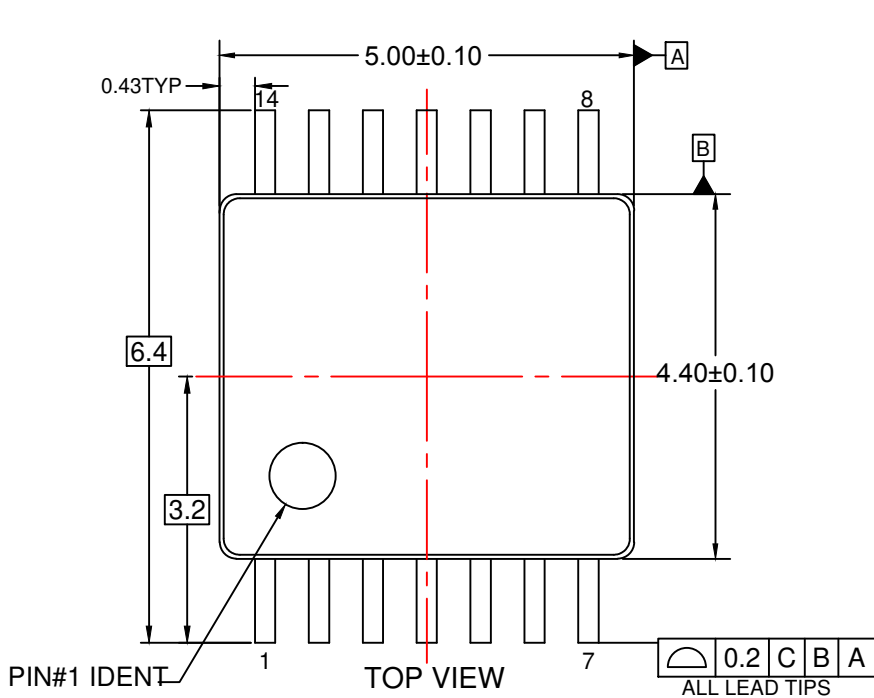

NOTES:

- A. CONFORMS TO JEDEC REGISTRATION MO-153, VARIATION AB, REF NOTE 6
- B. DIMENSIONS ARE IN MILLIMETERS.
- C. DIMENSIONS ARE EXCLUSIVE OF BURRS, MOLD FLASH, AND TIE BAR EXTRUSIONS
- D. DIMENSIONING AND TOLERANCES PER ANSI Y14.5M, 2009.
- E. LANDPATTERN STANDARD: SOP65P640X110-14M.
- F. DRAWING FILE NAME: MKT-MTC14rev7.



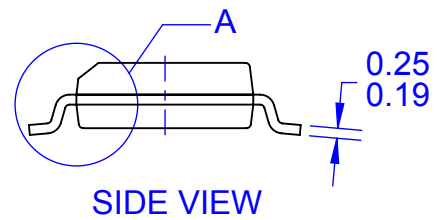
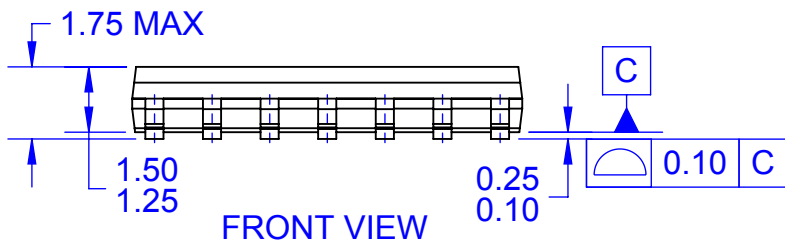
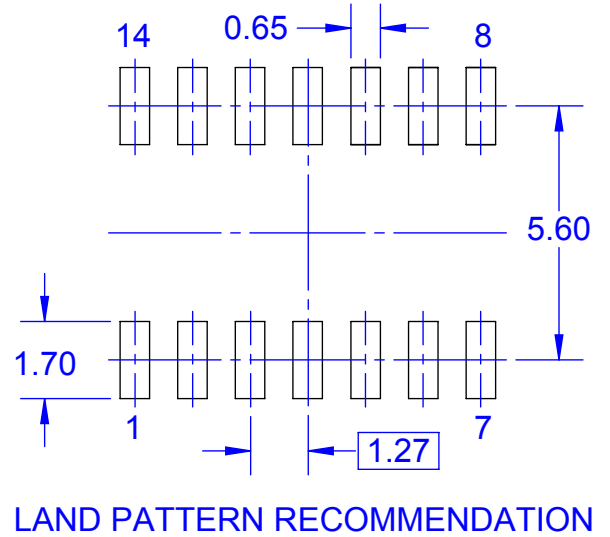
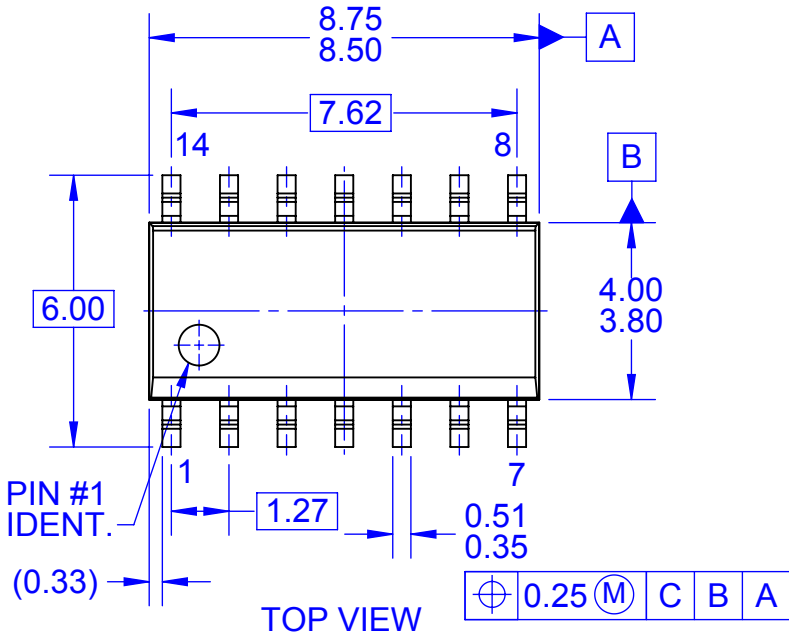

NOTES:

- A. CONFORMS TO JEDEC MS-012, VARIATION AB, ISSUE C
- B. ALL DIMENSIONS ARE IN MILLIMETERS
- C. DIMENSIONS DO NOT INCLUDE MOLD FLASH OR BURRS
- D. LAND PATTERN STANDARD: SOIC127P600X145-14M
- E. CONFORMS TO ASME Y14.5M, 2009
- D. DRAWING FILENAME: MKT-M14Arev14

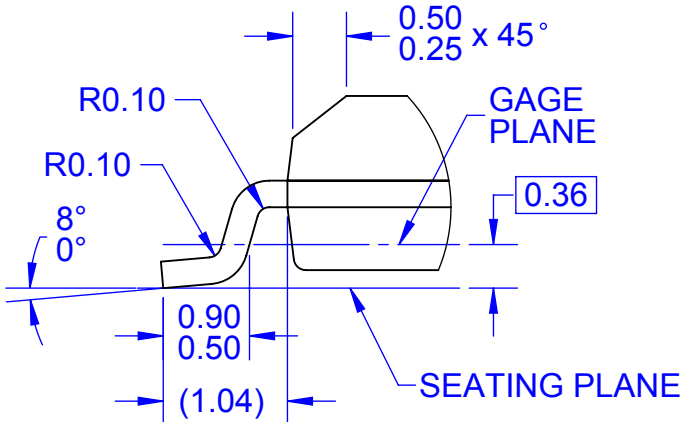

ON Semiconductor and  are trademarks of Semiconductor Components Industries, LLC dba ON Semiconductor or its subsidiaries in the United States and/or other countries. ON Semiconductor owns the rights to a number of patents, trademarks, copyrights, trade secrets, and other intellectual property. A listing of ON Semiconductor's product/patent coverage may be accessed at www.onsemi.com/site/pdf/Patent-Marking.pdf. ON Semiconductor reserves the right to make changes without further notice to any products herein. ON Semiconductor makes no warranty, representation or guarantee regarding the suitability of its products for any particular purpose, nor does ON Semiconductor assume any liability arising out of the application or use of any product or circuit, and specifically disclaims any and all liability, including without limitation special, consequential or incidental damages. Buyer is responsible for its products and applications using ON Semiconductor products, including compliance with all laws, regulations and safety requirements or standards, regardless of any support or applications information provided by ON Semiconductor. "Typical" parameters which may be provided in ON Semiconductor data sheets and/or specifications can and do vary in different applications and actual performance may vary over time. All operating parameters, including "Typicals" must be validated for each customer application by customer's technical experts. ON Semiconductor does not convey any license under its patent rights nor the rights of others. ON Semiconductor products are not designed, intended, or authorized for use as a critical component in life support systems or any FDA Class 3 medical devices or medical devices with a same or similar classification in a foreign jurisdiction or any devices intended for implantation in the human body. Should Buyer purchase or use ON Semiconductor products for any such unintended or unauthorized application, Buyer shall indemnify and hold ON Semiconductor and its officers, employees, subsidiaries, affiliates, and distributors harmless against all claims, costs, damages, and expenses, and reasonable attorney fees arising out of, directly or indirectly, any claim of personal injury or death associated with such unintended or unauthorized use, even if such claim alleges that ON Semiconductor was negligent regarding the design or manufacture of the part. ON Semiconductor is an Equal Opportunity/Affirmative Action Employer. This literature is subject to all applicable copyright laws and is not for resale in any manner.

PUBLICATION ORDERING INFORMATION

LITERATURE FULFILLMENT:

Literature Distribution Center for ON Semiconductor
19521 E. 32nd Pkwy, Aurora, Colorado 80011 USA
Phone: 303-675-2175 or 800-344-3860 Toll Free USA/Canada
Fax: 303-675-2176 or 800-344-3867 Toll Free USA/Canada
Email: orderlit@onsemi.com

N. American Technical Support: 800-282-9855 Toll Free
USA/Canada
Europe, Middle East and Africa Technical Support:
Phone: 421 33 790 2910
Japan Customer Focus Center
Phone: 81-3-5817-1050

ON Semiconductor Website: www.onsemi.com
Order Literature: <http://www.onsemi.com/orderlit>
For additional information, please contact your local
Sales Representative