

SOLENOID PRODUCT SPECIFICATION

PART No.	VOLTAGE	DUTY CYCLE	POWER (W)	CURRENT (A)	DCR (Ω) *
DSOL-1151-05C	5 VDC	100%	7.5	1.5	3.4
DSOL-1151-05E	5 VDC	25%, 60sec On	19	3.8	1.4
DSOL-1151-12C	12 VDC	100%	7.5	0.7	19.2
DSOL-1151-12E	12 VDC	25%, 60sec On	19	1.6	7.6
DSOL-1151-24C	24 VDC	100%	7.5	0.4	76.8
DSOL-1151-24E	24 VDC	25%, 60sec On	19	0.8	30.3

DRAWING SHOWN SOLENOID ENERGIZED

* Release value are ±10% at 25°C.
 * DCR VALUES ARE ±10% AT 25°C

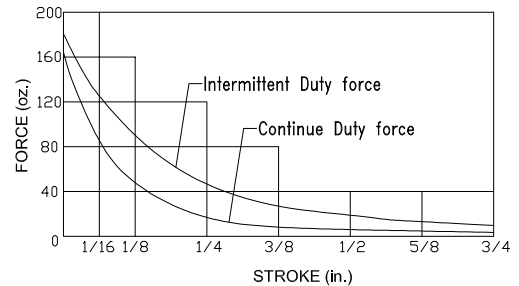
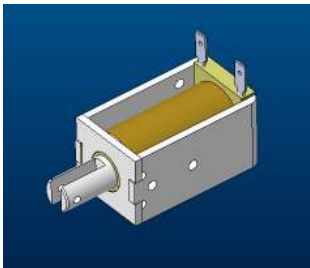
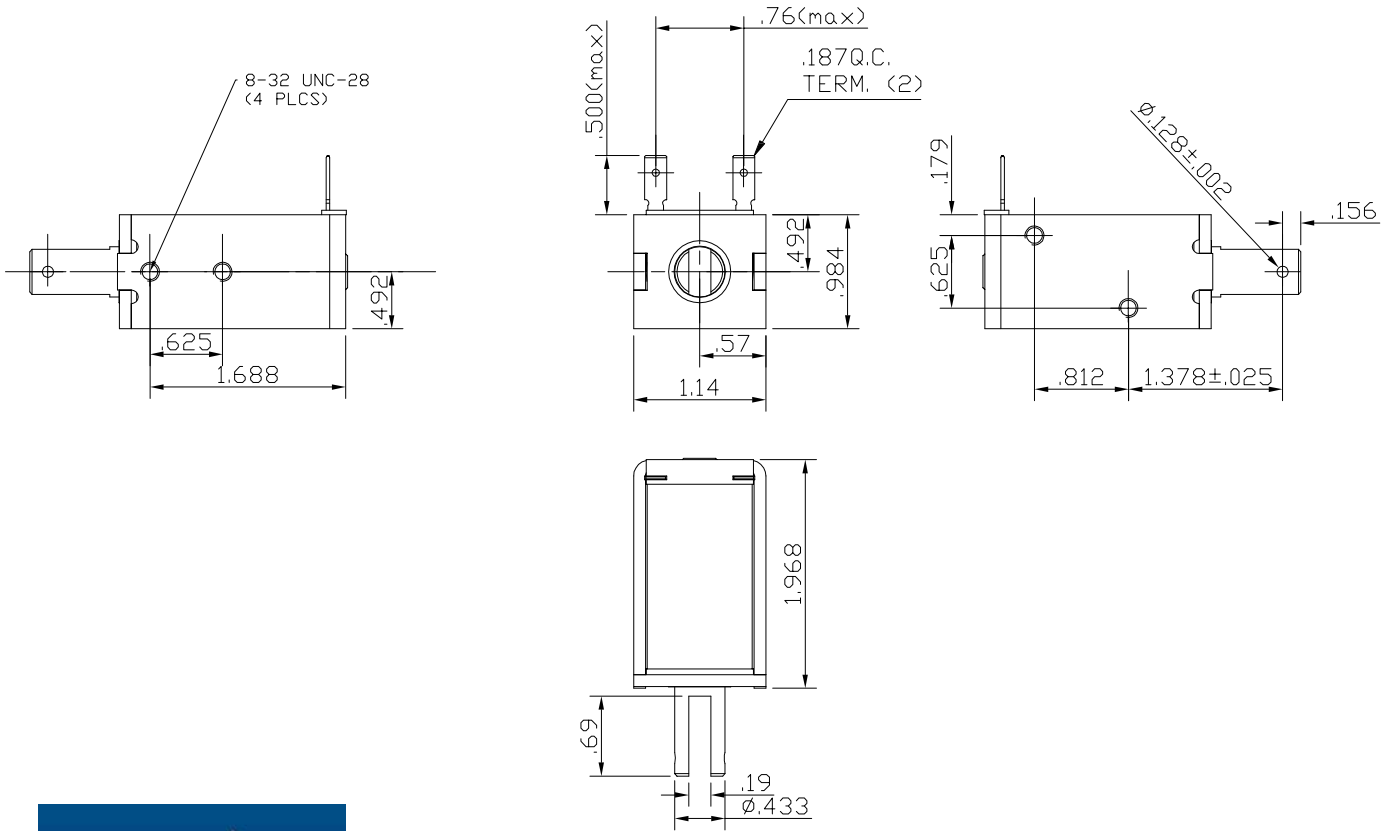

2. SCHEMATIC AND CONSTRUCTION :

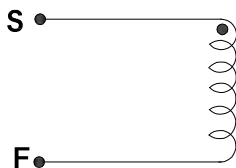

UNIT : inch.

UNLESS TOLERANCES.

X.X = ±0.02

X.XX = ±0.01

ANGLES = ±1°

INSULATION MATERIALS: UL CONSTRUCTION, CLASS B 130°C
 LIFE EXPECTANCY: 100K CYCLES OPERATIONS

LAYER TEST	IR. @500 Vdc.	HI-POT
(S-F) 500Vp. MIN.	COIL TO FRAME	@50/60Hz.,2mA
TEST ONLY COIL	50 MOHM MIN.	COIL TO FRAME
		1200Vac.,1s