

PRODUCT NUMBER
76383-YXXLF

PLATING

3=0.76µm GOLD/GXT ON CONTACT AREA
3.81µm TIN-LEAD ON TAIL

4=3.81µm TIN-LEAD ON CONTACT AREA
AND ON TAIL

WHEN "LF" IS REQUIRED, 2µm MIN
MATTE TIN OVER 1.27µm MIN NICKEL
IS PROVIDED INSTEAD OF TIN-LEAD

WHEN REQUIRED, ADD SUFFIX LETTER "LF"
INDICATES THE PRODUCT IS RoHS
COMPATIBLE, SEE NOTE 7

NUMBER OF POSITIONS PER ROW: 02 TO 36

NOTES:

- BODY MATERIAL: POLYESTER 30% GLASSFILLED COLOR BLUE, FLAME RETARDANT PER UL-94 V0.
- CONTACT MATERIAL: PHOSPHOR BRONZE.
- 15N MIN PIN RETENTION IN EITHER DIRECTION
- 0.6 MAX PROTRUSION PERMITTED AT 4 PLACES
- PACKAGING :
- POLYBAGS FROM 2 x 02 TO 2 x 06 POSITIONS
- TUBE FROM 2 x 07 TO 2 x 36 POSITIONS
- TO DETERMINE DIMENSIONS :
N = NUMBER OF POSITIONS PER ROW
EXAMPLE : 8 POS N x 2.54 = 20.32mm
- RoHS COMPATIBLE PRODUCT SPECIFICATIONS

- PLATING:
- "LF" MEANS THE PRODUCT IS LEAD-FREE,
2µm MINIMUM MATTE TIN OVER 1.27µm
MINIMUM NICKEL UNDERPLATE.
- MANUFACTURING PROCESS COMPATIBILITY
- THE HOUSING WILL WITHSTAND EXPOSURE TO
245°C ±5°C SOLDER BATH TEMPERATURE FOR
5 SECONDS IN A WAVE SOLDER APPLICATION
WITH A 1.6mm MIN THICK CIRCUIT BOARD.
- LABELING:
- MEETS PACKAGING SPECS AS PER GS-14-920
- LEGAL STATEMENT: SEE GS-47-0004

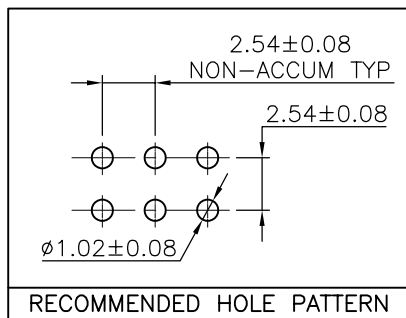
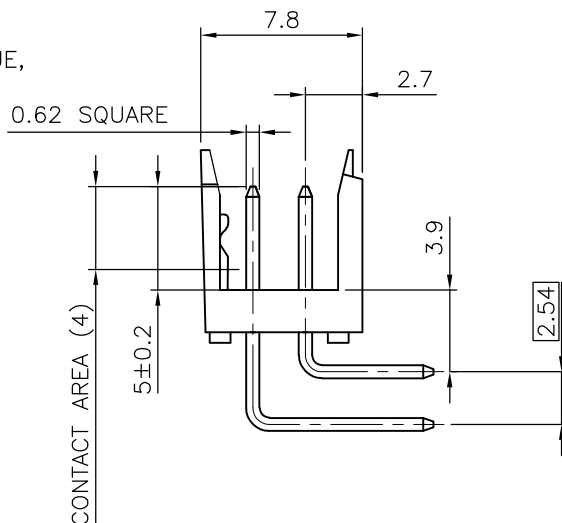

TOP VIEW

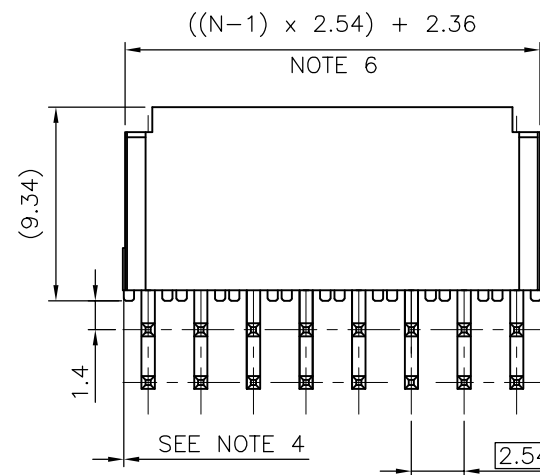
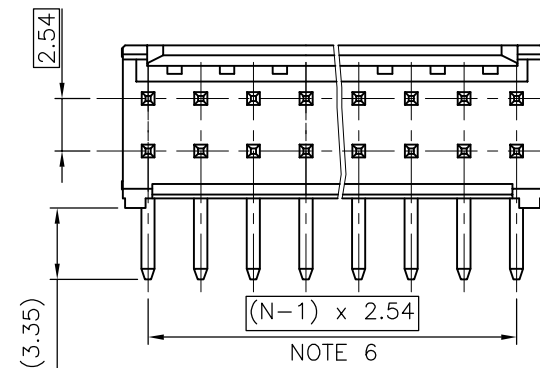

| | | | | | | | | | |
|-------------|----------|----------------|----------|---------------------------------------|---------------|------------|--|------------------|--|
| mat'l. code | | surface | | tolerance | | projection | | product family | |
| SEE NOTE | | ISO 1302 | | ISO 406 ISO 1101 | | mm | | DUBOX | |
| ltr | ecn no | dr | date | tolerances unless otherwise specified | | mm | | title | |
| M | F10-0043 | LMU | 10.05.03 | angles | .X ±0.3 | mm | | SHR. HEADER | |
| N | F-21810 | AMA | 15.06.19 | linear | .XX ±0.15 | mm | | RA DR TMT | |
| P | F-38327 | DDE | 20.09.11 | | .XXX ±0.05 | scale 5:1 | | dwg no | |
| J | F06-0228 | LMU | 06.07.11 | dr | D.LE 01.01.24 | FCI | | sheet 1 of 1 | |
| K | F06-0333 | LMU | 06.12.06 | engr | JM.C 01.01.24 | | | 76383 | |
| L | F08-0147 | YOY | 08.04.14 | chr | JM.C 01.01.24 | | | size | |
| | | | | appd | JF.N 01.01.24 | | | A3 | |
| sheet index | | revision sheet | | | | | | type | |
| | | | | | | | | CUSTOMER Drawing | |