

LEAD-FREE PLATING

BACKPLANE HOLE PATTERN (COMPONENT SIDE)

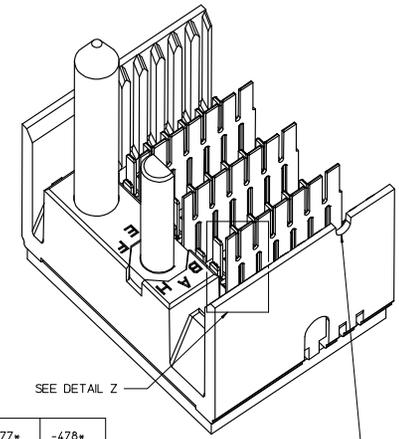
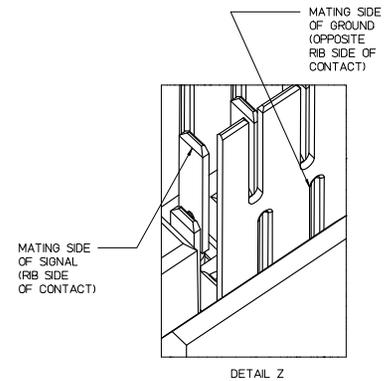

- NOTES:
1. MATERIAL: HOUSING - LIQUID CRYSTAL POLYMER (LCP) GLASS-FILLED, UL 94V-0, COLOR - GRAY. SIGNAL CONTACT AND GROUND BLADE - HIGH PERFORMANCE COPPER ALLOY.
  2. FINISHES: SELECTIVE GOLD (Au) ON CONTACT AREA, SELECTIVE MATTE TIN (Sn) ON PCB TAILS, NICKEL (Ni) OVERALL.
  3. THIS PART CONFORMS TO MOLEX PRODUCT SPECIFICATION PS-75221-999.
  4. FOR MIXED CONTACT MATING LENGTHS CONSULT MOLEX FOR AVAILABILITY. CONTACT PAIRS MUST BE THE SAME LENGTH.
  5. FOR SPECIFIC PART NUMBER AND MATING INFORMATION PLEASE REFER TO CHART.
  6. PACKAGE PER PK-70873-563.
  7. MARK PART NUMBER AND DATE CODE APPROXIMATELY WHERE SHOWN.
  8. OPTIONAL HOLE LOCATION FOR GROUNDED GUIDE PIN OR ADDITIONAL GUIDE PIN SUPPORT. FOR GROUNDED GUIDE PIN, HOLE TO BE PLATED, DRILL SIZE Ø2.58, PAD SIZE Ø5.50
  9. THIS PART CONFORMS TO MOLEX COSMETIC SPECIFICATION PS-45499-002 CLASS B.
  10. MAPS (MOLEX ADVANCED PLATING SYSTEM).

THE PRIMARY CARTON WITH A LABEL STATING "ELV AND RoHS COMPLAINT" IS LEAD FREE. CARTONS WITHOUT THIS LABEL MAY CONTAIN LEAD.

P/N	-470*	-471*	-472*	-473*	-474*	-475*	-476*	-477*	-478*
75235-( )	0	A	B	C	D	E	F	G	H
KEYING PIN ORIENTATION									

NOTCH DESIGNATES APPROXIMATE LOCATION OF PIN A1, ARCH & NOTCH ON OPPOSITE SIDE OF PART MARKING

1. MATERIAL: HOUSING - LIQUID CRYSTAL POLYMER (LCP) GLASS-FILLED, UL 94V-0, COLOR - GRAY. SIGNAL CONTACT AND GROUND BLADE - HIGH PERFORMANCE COPPER ALLOY.
2. FINISHES: SELECTIVE GOLD (Au) ON CONTACT AREA, SELECTIVE MATTE TIN (Sn) ON PCB TAILS, NICKEL (Ni) OVERALL.
3. THIS PART CONFORMS TO MOLEX PRODUCT SPECIFICATION PS-75221-999.
4. FOR MIXED CONTACT MATING LENGTHS CONSULT MOLEX FOR AVAILABILITY. CONTACT PAIRS MUST BE THE SAME LENGTH.
5. FOR SPECIFIC PART NUMBER AND MATING INFORMATION PLEASE REFER TO CHART.
6. PACKAGE PER PK-70873-563.
7. MARK PART NUMBER AND DATE CODE APPROXIMATELY WHERE SHOWN.
8. OPTIONAL HOLE LOCATION FOR GROUNDED GUIDE PIN OR ADDITIONAL GUIDE PIN SUPPORT. FOR GROUNDED GUIDE PIN, HOLE TO BE PLATED, DRILL SIZE Ø2.58, PAD SIZE Ø5.50
9. THIS PART CONFORMS TO MOLEX COSMETIC SPECIFICATION PS-45499-002 CLASS B.
10. MAPS (MOLEX ADVANCED PLATING SYSTEM).

MODULE ORIENTATION	RIGHT = 4
KEYING ORIENTATION	0=NONE 1=A 2=B ETC...
PIN LENGTH DIM "M"	GOLD (Au) THICKNESS micrometers
0-3.55 mm	
1-4.55 mm	0.25 (MAPS)
2-5.55 mm	
3-3.55 mm	0.76
4-4.55 mm	
5-5.55 mm	
7-3.55 mm	1.27
8-4.55 mm	
9-5.55 mm	

REV TO LEAD-FREE ECC NO: UCP2013-0690 DRAWINGS 2012/09/06 CHYOMOLFE APPROX/MILLER 2012/12/05	QUALITY SYMBOLS ▽=0 ▽=0 ▽=0	GENERAL TOLERANCES (UNLESS SPECIFIED)	DIMENSION STYLE MM ONLY	SCALE 5:1	DESIGN UNITS METRIC	THIRD ANGLE PROJECTION
		4 PLACES ±--- 3 PLACES ±--- 2 PLACES ±0.25 1 PLACE ±0.38 0 PLACE ±---	mm INCH +--- +--- +--- +--- +--- +--- +--- +---	DRAWN BY JB INGHAM 2006/11/30	DATE	TITLE GBX 4-PAIR BACKPLANE LF 7-COLUMN RIGHT END SALES ASSEMBLY DRAWING
ANGULAR ±1/2° DRAFT WHERE APPLICABLE MUST REMAIN WITHIN DIMENSIONS	SIZE D	MATERIAL NO. SEE CHART	DOCUMENT NO. SD-75235-470	SHEET NO. 1 OF 1		

THIS DRAWING CONTAINS INFORMATION THAT IS PROPRIETARY TO MOLEX INCORPORATED AND SHOULD NOT BE USED WITHOUT WRITTEN PERMISSION

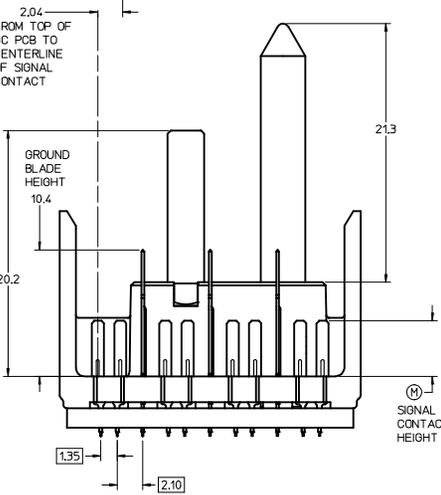
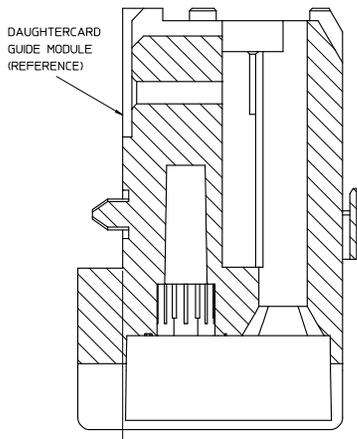

- NOTES:**
1. MATERIAL: HOUSING - LIQUID CRYSTAL POLYMER (LCP) GLASS-FILLED, UL 94V-0, COLOR - GRAY. SIGNAL CONTACT AND GROUND BLADE - HIGH PERFORMANCE COPPER ALLOY.
  2. FINISHES: SELECTIVE GOLD (Au) ON CONTACT AREA, SELECTIVE MATTE TIN (Sn) ON PCB TAILS, NICKEL (Ni) OVERALL.
  3. THIS PART CONFORMS TO MOLEX PRODUCT SPECIFICATION PS-75221-999.
  4. FOR MIXED CONTACT MATING LENGTHS CONSULT MOLEX FOR AVAILABILITY. CONTACT PAIRS MUST BE THE SAME LENGTH.
  5. FOR SPECIFIC PART NUMBER AND MATING INFORMATION PLEASE REFER TO CHART.
  6. PACKAGE PER PK-70873-563.
  7. MARK PART NUMBER AND DATE CODE APPROXIMATELY WHERE SHOWN.
  8. OPTIONAL HOLE LOCATION FOR GROUNDED GUIDE PIN OR ADDITIONAL GUIDE PIN SUPPORT. FOR GROUNDED GUIDE PIN, HOLE TO BE PLATED, DRILL SIZE  $\varnothing 2.58$ , PAD SIZE  $\varnothing 5.50$ .
  9. THIS PART CONFORMS TO MOLEX COSMETIC SPECIFICATION PS-45499-002 CLASS B.
  10. MAPS (MOLEX ADVANCED PLATING SYSTEM).

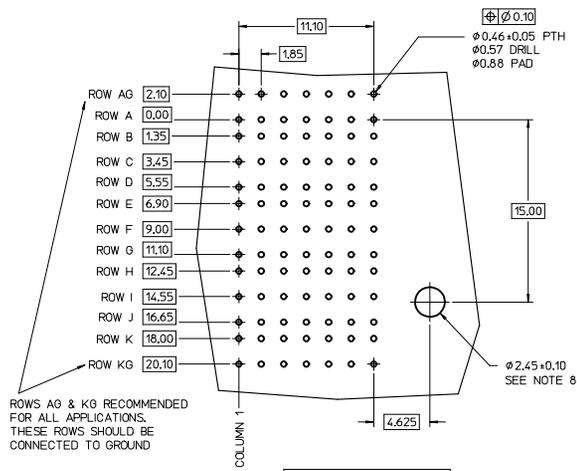
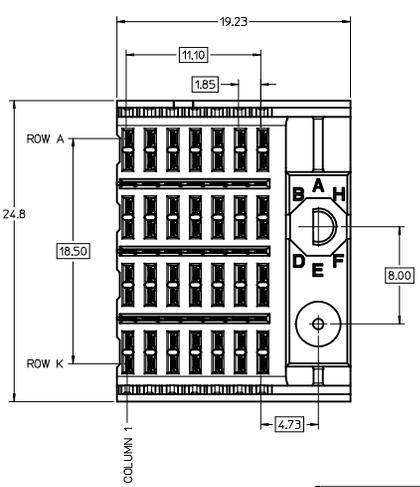

ROWS AG & KG RECOMMENDED FOR ALL APPLICATIONS. THESE ROWS SHOULD BE CONNECTED TO GROUND

BACKPLANE HOLE PATTERN (COMPONENT SIDE)

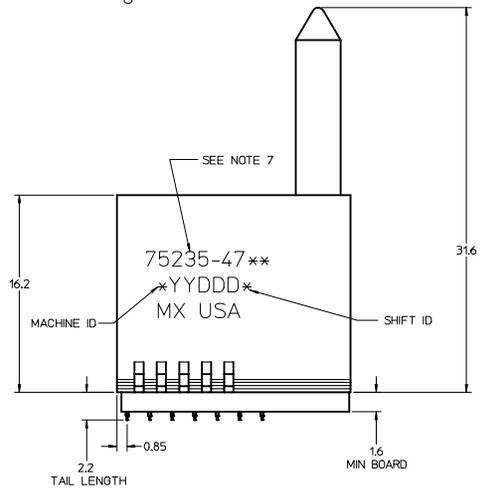
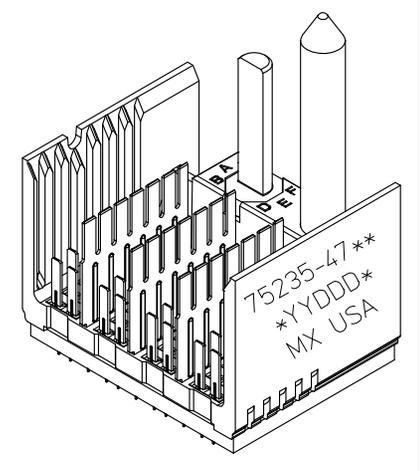

THE PRIMARY CARTON WITH A LABEL STATING "ELV AND RoHS COMPLAINT" IS LEAD FREE. CARTONS WITHOUT THIS LABEL MAY CONTAIN LEAD.

LEAD-FREE PLATING

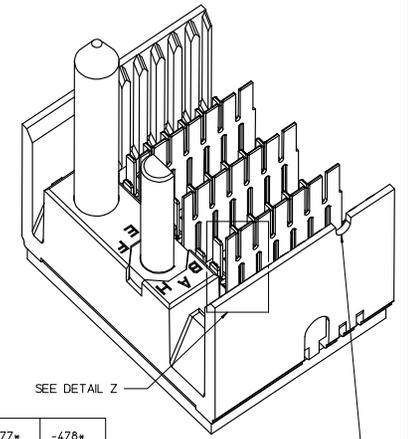
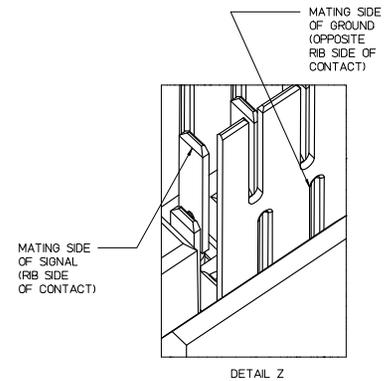

P/N	-470*	-471*	-472*	-473*	-474*	-475*	-476*	-477*	-478*
75235-( )	0	A	B	C	D	E	F	G	H
KEYING PIN ORIENTATION									

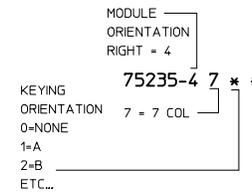

PIN LENGTH DIM "M"	GOLD (Au) THICKNESS micrometers
0-3.55 mm	
1-4.55 mm	0.25 (MAPS)
2-5.55 mm	
3-3.55 mm	0.76
4-4.55 mm	
5-5.55 mm	
7-3.55 mm	1.27
8-4.55 mm	
9-5.55 mm	

<b>REV TO LEAD-FREE</b> EEC NO: UCP2013-0690 DRWNGES 2012/09/06 CHYKMOLEF 2012/09/06 APPR:SMILLER 2012/12/05	QUALITY SYMBOLS ▽=0 ▽=0 ▽=0	GENERAL TOLERANCES (UNLESS SPECIFIED) mm INCH 4 PLACES ±--- ±--- 3 PLACES ±--- ±--- 2 PLACES ±0.25 ±--- 1 PLACE ±0.38 ±--- 0 PLACE ±--- ±---	DIMENSION STYLE MM ONLY DRAWN BY DATE JB INGHAM 2006/11/30 CHECKED BY DATE SREED 2006/11/30 APPROVED BY DATE SMILLER 2012/12/05	SCALE DESIGN UNITS 5:1 METRIC THIRD ANGLE PROJECTION	TITLE GBX 4-PAIR BACKPLANE LF 7-COLUMN RIGHT END SALES ASSEMBLY DRAWING
		ANGULAR ±1/2° DRAFT WHERE APPLICABLE MUST REMAIN WITHIN DIMENSIONS	MATERIAL NO. SEE CHART	DOCUMENT NO. SD-75235-470	SHEET NO. 1 OF 1

THIS DRAWING CONTAINS INFORMATION THAT IS PROPRIETARY TO MOLEX INCORPORATED AND SHOULD NOT BE USED WITHOUT WRITTEN PERMISSION