

LOC		DIST		REVISIONS			
FT		P	LTR	DESCRIPTION	DATE	DWN	APVD
	8	N1		REVISED PER ECO-07-000274	1/5/07	SS	GS

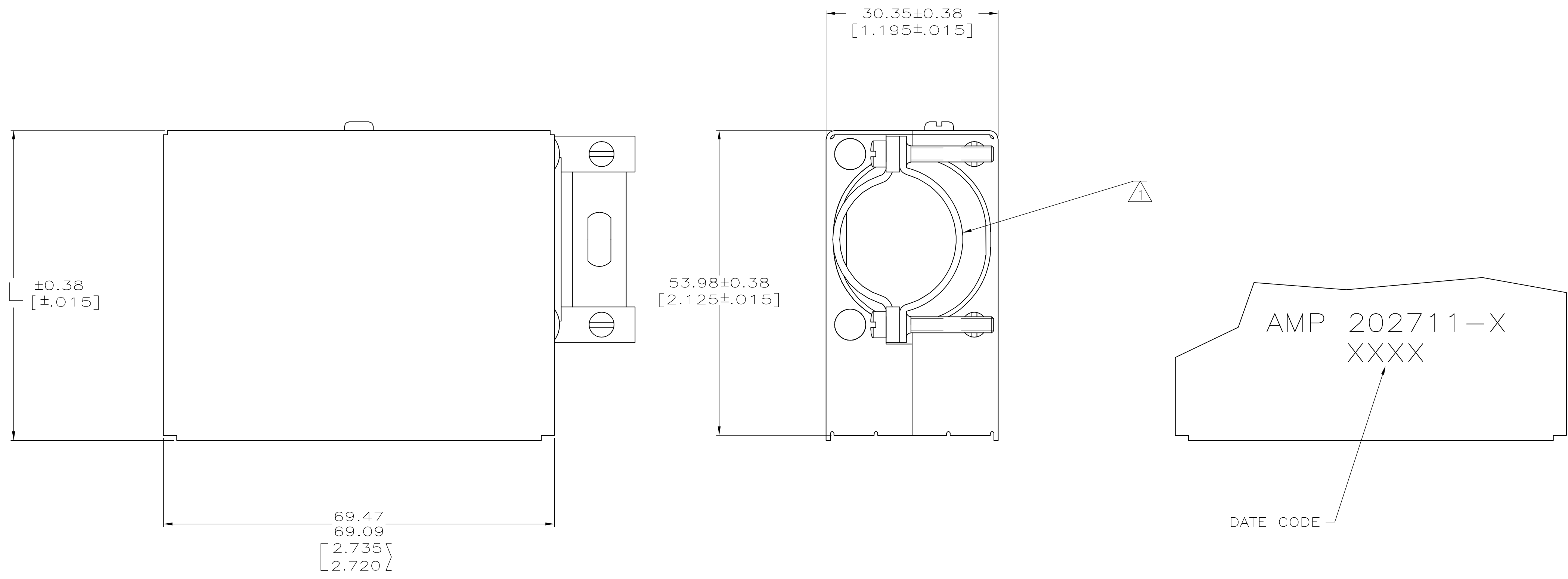

ASSEMBLED VIEW

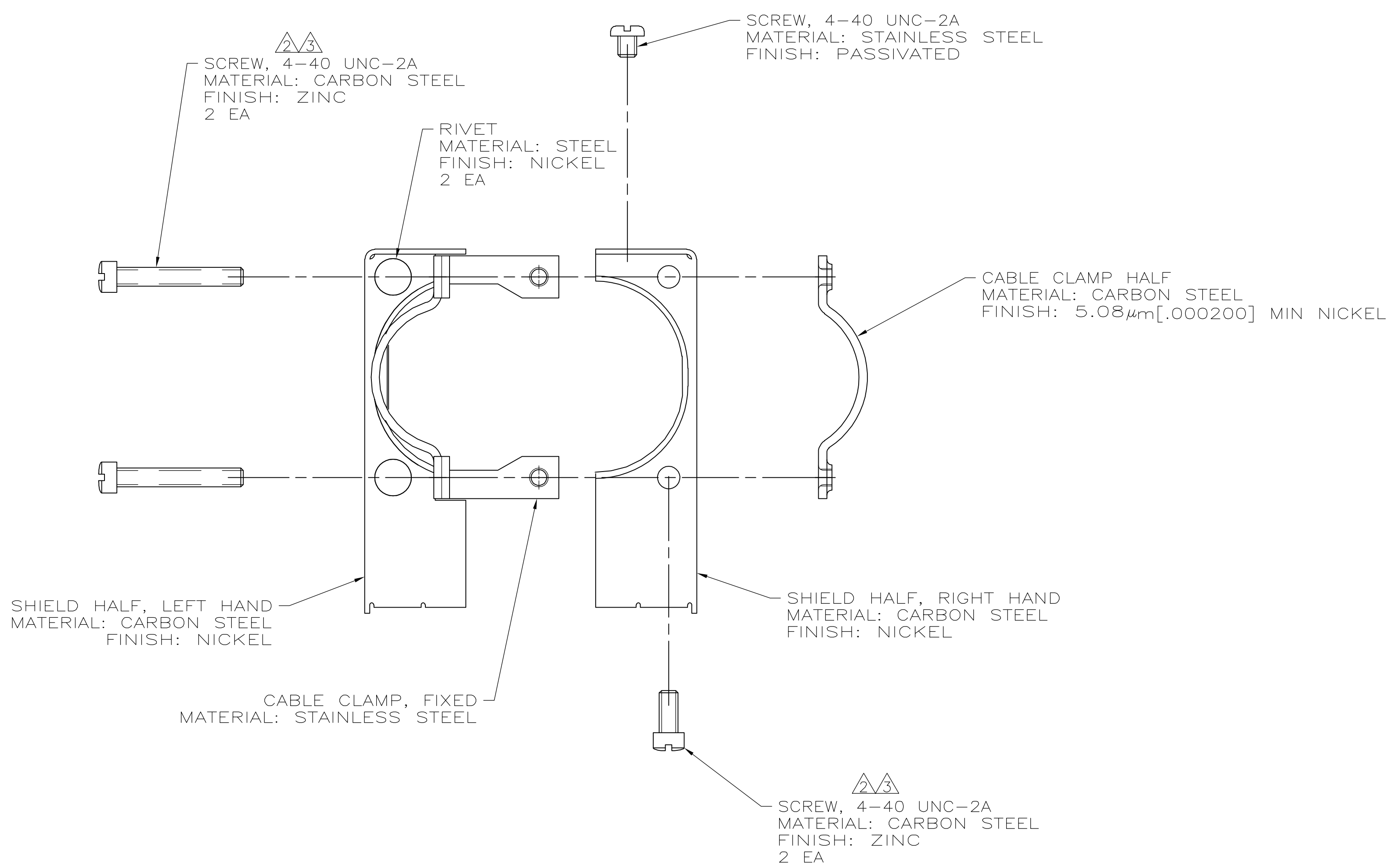

- △ CABLE CLAMP WILL ACCEPT 12.70 TO 25.40 [.500 TO 1.000] DIA CABLE (USE BUSHING 202038 OR 202039 FOR 12.70 [.500] DIA CABLE).
- △ ZINC PLATING WITH HEXAVALENT CHROMATE COATING.
- △ ZINC PLATING WITHOUT HEXAVALENT CHROMATE COATING.

△	71.04 [2.797]	1-202711-2
△	54.86 [2.160]	1-202711-1
△	71.04 [2.797]	202711-3
△	54.86 [2.160]	202711-1
SCREW FINISH	L	PART NUMBER

THIS DRAWING IS A CONTROLLED DOCUMENT.

DIMENSIONS: mm	TOLERANCES UNLESS OTHERWISE SPECIFIED:	DIN C. OBERMAN 22 AUG 96	CHK R. STONE 06 AUG 96	APVD G. STEINHÄUER 21 JAN 97	NAME	tyco Electronics	Tyco Electronics Corporation Harrisburg, PA 17105-3608
0 PLC ± -	1 PLC ± -	2 PLC ± -	3 PLC ± -	4 PLC ± -	ANGLES ± -	FINISH	RESTRICTED TO
MATERIAL	FINISH	WEIGHT	SIZE	CAGE CODE	DRAWING NO	SCALE	SHEET
			A1	00779	202711	2:1	1 OF 1
CUSTOMER DRAWING		SCALE		SHEET		REV	