

TX517 Dual Channel, 17-Level With RTZ, Integrated Ultrasound Transmitter

TX517 is a fully integrated, dual channel, high voltage Transmitter designed by Texas Instruments Incorporated. This EVM provides a means to evaluate the functionality of the device. The EVM includes a FPGA to provide an embedded pattern generator and digital control of the device. The output pattern and configuration settings are controlled by 8 push buttons on the EVM.

Contents

1	Default Configuration	3
2	Buttons	4
3	SYNC Trigger	5
4	Power up TX517	6
5	Power Supplies for Output Waveform	7
	5.1 Input/Output Pattern	8
6	Board Configuration	14
7	EVM Schematics	15
8	Bill of Materials	22
9	PCB Layouts	25

List of Figures

1	Tx517 EVM Basic Configuration	3
2	Power-Up Indications	6
3	Input Pattern for 17-Level	8
4	Output Waveform for 17-Level	8
5	Input Pattern for 5-Level	9
6	Output Waveform for 5-Level	9
7	Input Pattern for 3-Level	10
8	Output Waveform for 3-Level	10
9	Output Waveform for 2-Level	11
10	Output Waveform for 2-Level With Three Cycles	11
11	Output Waveform for 4-Level	12
12	Output Waveform for 32-Level	12
13	Output Waveform for 32-Level With Two Cycles	13
14	Schematic (1 of 8)	15
15	Schematic (2 of 8)	16
16	Schematic (3 of 8)	17
17	Schematic (4 of 8)	18
18	Schematic (5 of 8)	19
19	Schematic (6 of 8)	19
20	Schematic (7 of 8)	20
21	Schematic (8 of 8)	21

List of Tables

1	Buttons	4
---	---------------	---

2	PRF.....	4
3	Cycle.....	4
4	Frequency.....	4
5	Pattern Depth	5
6	Patterns of Different Level.....	5
7	Pin Definition for J1-Header	7
8	Pin Definition for P1-Header.....	7
9	Input/Output, Power, and USB	14
10	LED Indicators.....	14
11	Bill of Materials (BOM).....	22

Trademarks

All trademarks are the property of their respective owners.

General Texas Instruments High Voltage Evaluation (TI HV EVM) User Safety Guidelines

WARNING

Always follow TI's set-up and application instructions, including use of all interface components within their recommended electrical rated voltage and power limits. Always use electrical safety precautions to help ensure your personal safety and those working around you. Contact TI's Product Information Center <http://support/ti.com> for further information.

Save all warnings and instructions for future reference.

Failure to follow warnings and instructions may result in personal injury, property damage or death due to electrical shock and burn hazards.

The term TI HV EVM refers to an electronic device typically provided as an open framed, unenclosed printed circuit board assembly. It is *intended strictly for use in development laboratory environments, solely for qualified professional users having training, expertise and knowledge of electrical safety risks in development and application of high voltage electrical circuits. Any other use and/or application are strictly prohibited by Texas Instruments.* If you are not suitable qualified, you should immediately stop from further use of the HV EVM.

1. Work Area Safety:

- (a) Keep work area clean and orderly.
- (b) Qualified observer(s) must be present anytime circuits are energized.
- (c) Effective barriers and signage must be present in the area where the TI HV EVM and its interface electronics are energized, indicating operation of accessible high voltages may be present, for the purpose of protecting inadvertent access I
- (d) All interface circuits, power supplies, evaluation modules, instruments, meters, scopes and other related apparatus used in a development environment exceeding 50Vrms/75VDC must be electrically located within a protected Emergency Power Off EPO protected power strip.
- (e) Use stable and non conductive work surface.
- (f) Use adequately insulated clamps and wires to attach measurement probes and instruments. No freehand testing whenever possible.

2. Electrical Safety:

As a precautionary measure, it is always a good engineering practice to assume that the entire EVM may have fully accessible and active high voltages.

- (a) De-energize the TI HV EVM and all its inputs, outputs and electrical loads before performing any electrical or other diagnostic measurements. Revalidate that TI HV EVM power has been safely de-energized.
- (b) With the EVM confirmed de-energized, proceed with required electrical circuit configurations, wiring, measurement equipment hook-ups and other application needs, while still assuming the EVM circuit

and measuring instruments are electrically live.

(c) Once EVM readiness is complete, energize the EVM as intended.

WARNING

While the EVM is energized, never touch the EVM or its electrical circuits as they could be at high voltages capable of causing electrical shock hazard.

3. Personal Safety:

(a) Wear personal protective equipment e.g. latex gloves or safety glasses with side shields or protect EVM in an adequate lucent plastic box with interlocks from accidental touch.

Limitation for safe use: EVMs are not to be used as all or part of a production unit.

1 Default Configuration

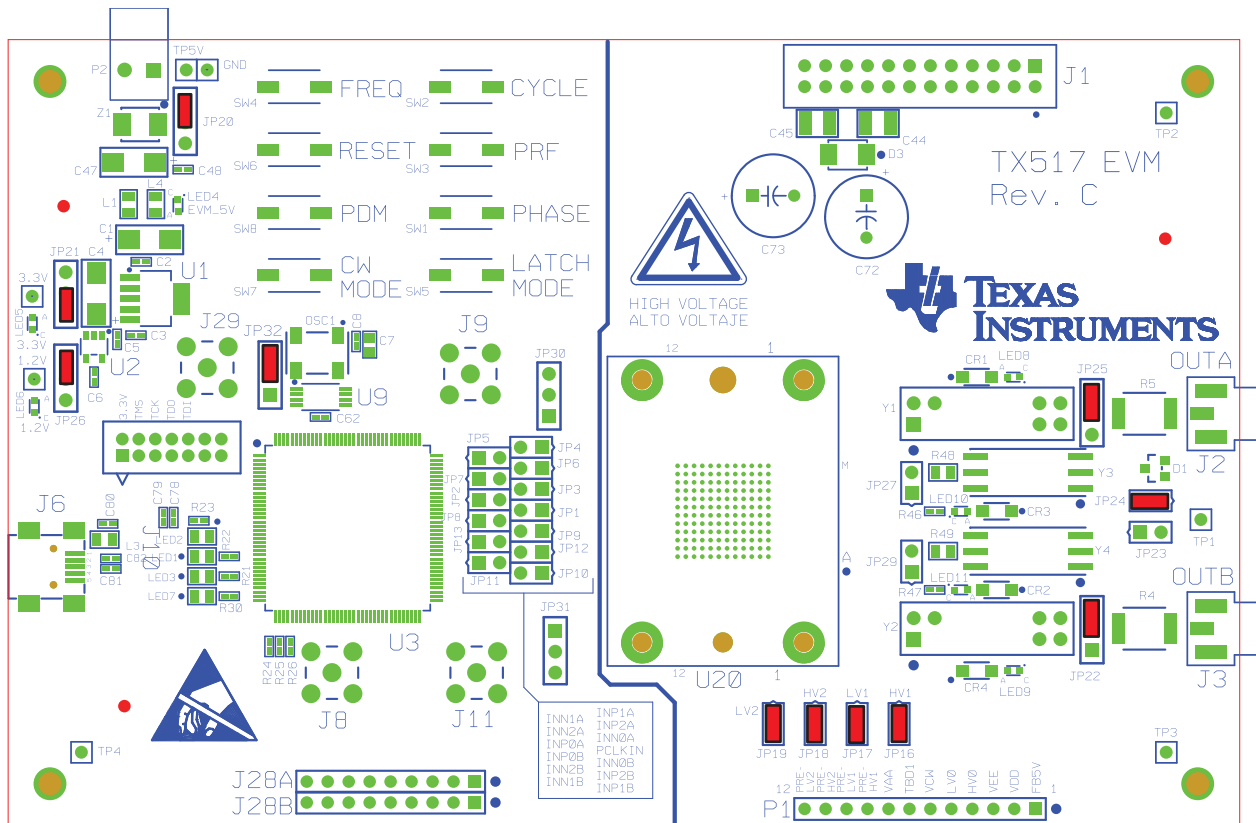

Figure 1. Tx517 EVM Basic Configuration

2 Buttons

There are eight buttons for controlling the output waveform settings. They are listed in [Table 1](#).

Table 1. Buttons

Button	Functionality
PHASE_BUTTON	Each time the button is pressed, the current INP _x pattern becomes the pattern for INN _x , the current INN _x pattern becomes the pattern for INP _x .
PRF_BUTTON	Changes the Pulse Repetition Frequency of the output waveform as given in Table 2 Each press increases the PRF and then cycles back to 0.
CYCLE_BUTTON	Changes the number of times the output pattern cycles within the pulse burst, as given in the Table 3 . Each press moves 1 level up and then back to 0
FREQ_BUTTON	Changes the Frequency of the output waveform as given in the Table 4 . Each press increases the frequency and then cycles back to 0
RESET_BUTTON	Reset all the setting to its default
PDM_BUTTON	One press changes the mode to Power down mode.
CW_MODE_BUTTON	First six times the button is pressed will change the pattern depth as shown in Table 5 . Seventh press will change the device to CW mode. In CW mode, pressing the button will revert back to 17-level. The latch mode is unaffected. Refer to Table 5 and Table 6 .
LATCH_MODE_BUTTON	First press changes to latch mode. Every consecutive pulse will toggle the mode between Latch and Non latch mode

Table 2. PRF

Index	PRF(kHz)	Comments
0	0.5	
1	1	
2	5	17-level Ramp Only
3	10	17-level Ramp Only

Table 3. Cycle

Index	PRF (kHz)	Comments
0	1	Longer than 5-level Only
1	2	Longer than 5-level Only
2	3	
3	5	
4	10	

Table 4. Frequency

Index	Frequency (MHz)	Comments
0	10	
1	20	
2	50	
3	100	

There are 7 patterns: 17-, 5-, 3-, 32-, 4- and 2-level. The patterns are given in [Table 6](#).

Table 5. Pattern Depth

Index	Pattern Depth	Comments
0	17	
1	5	
2	3	
3	32	
4	4	
5	2	
6	CW	

Table 6. Patterns of Different Level

17 level			5 level			3 level		
S/N	Pattern	Level	S/N	Pattern		S/N	Pattern	
1	516	8	1	516	8	1	516	8
2	514	7	2	1026	4	2	2145	0
3	577	6	3	2145	0	3	264	-8
4	1028	5	4	144	-4			
5	1026	4	5	264	-8			
6	1089	3						
7	2084	2						
8	2082	1						
9	2145	0						
10	81	-1						
11	73	-2						
12	2208	-3						
13	144	-4						
14	136	-5						
15	2336	-6						
16	272	-7						
17	264	-8						

3 SYNC Trigger

A **Sync trigger** pulse is generated at the start of the pattern transmission for triggering the monitoring device. Sync pulse will be 5 pattern clock cycle wide and it is active high. Sync pulse output thru J8 SMA connector..

4 Power up TX517

Connect +5V adaptor to P2 connector.

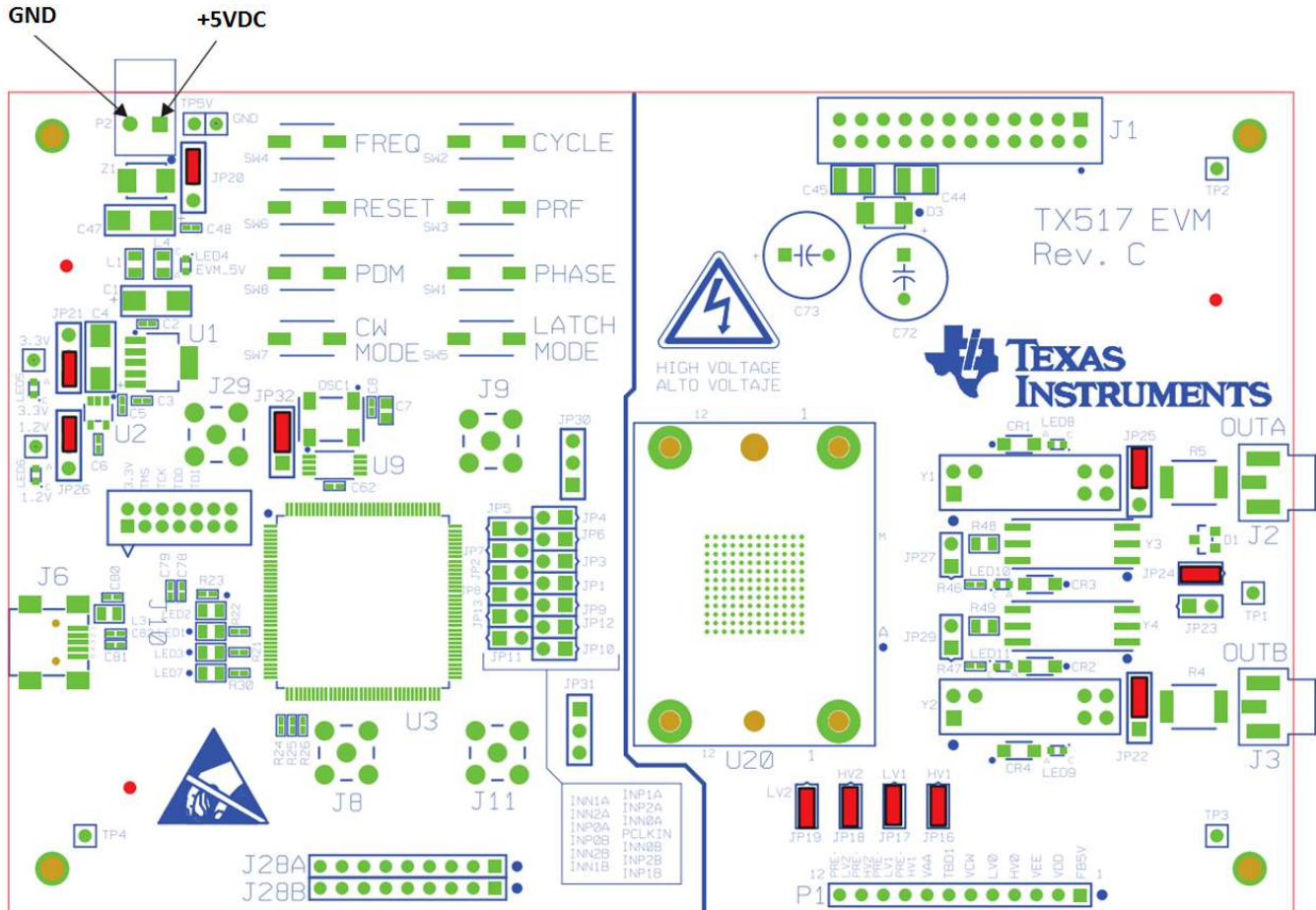

Figure 2. Power-Up Indications

5 Power Supplies for Output Waveform

Either J1-Header or P1-Header but not both, is used for this purpose.

WARNING

User may be exposed to high voltage depending on power supplies setting !

Table 7. Pin Definition for J1-Header

Pin	Voltage ⁽¹⁾	Pin	Voltage	COMMENT
1	GND	2	OPEN	FB5V
3	GND	4	+5 V	VDD
5	GND	6	-5 V	VEE
7	GND	8	+1.9 V	HV0
9	GND	10	-1.9 V	LV0
11	GND	12	+11 V	VCW
13	GND	14	OPEN	OPEN
15	GND	16	+2.5 V	VAA
17	GND	18	+61 V	HV1
19	GND	20	-20.9 V	LV1
21	GND	22	+32 V	HV2
23	GND	24	-11.9 V	LV2

⁽¹⁾ Use a GND test point for ground

Table 8. Pin Definition for P1-Header

Pin	Voltage	COMMENT
1	OPEN	FB5V
2	+5 V	VDD
3	-5 V	VEE
4	+1.9 V	HV0
5	-1.9 V	LV0
6	+11 V	VCW
7	OPEN	OPEN
8	+2.5 V	VAA
9	+61 V	HV1
10	-20.9 V	LV1
11	+32 V	HV2
12	-11.9 V	LV2

5.1 Input/Output Pattern

- 17 Level

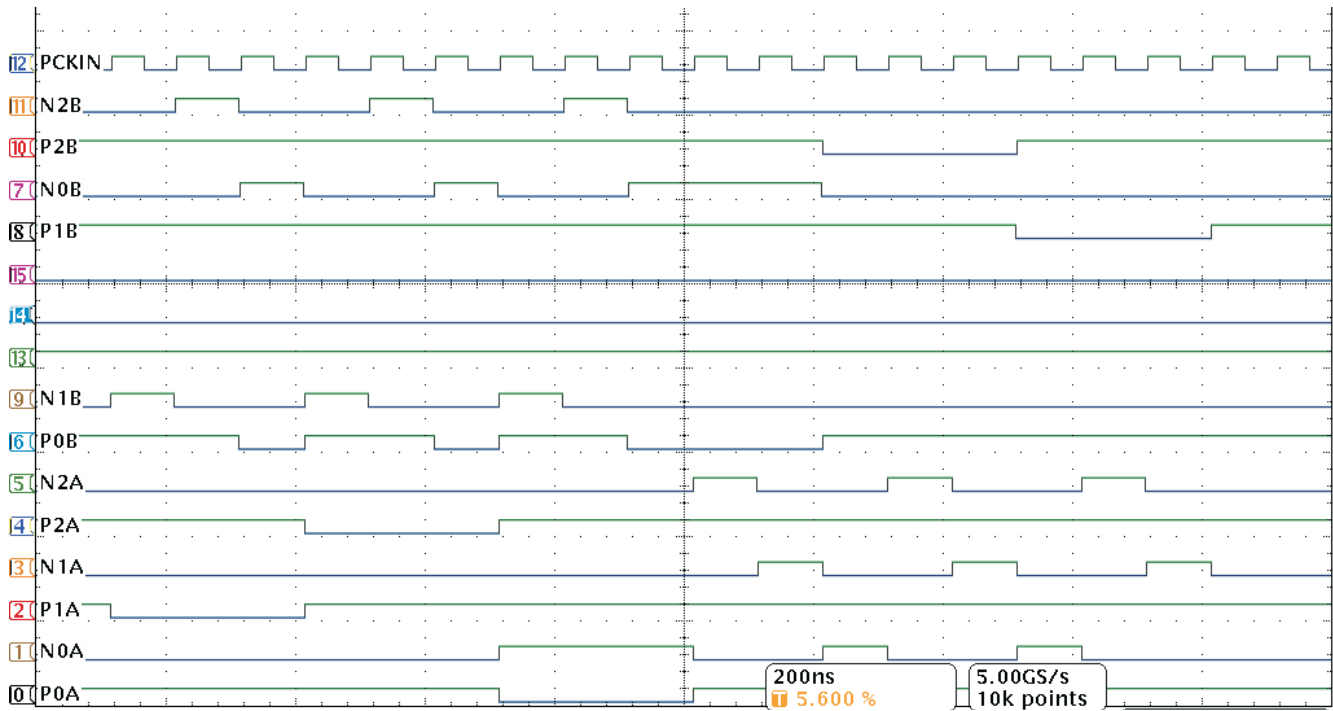

Figure 3. Input Pattern for 17-Level

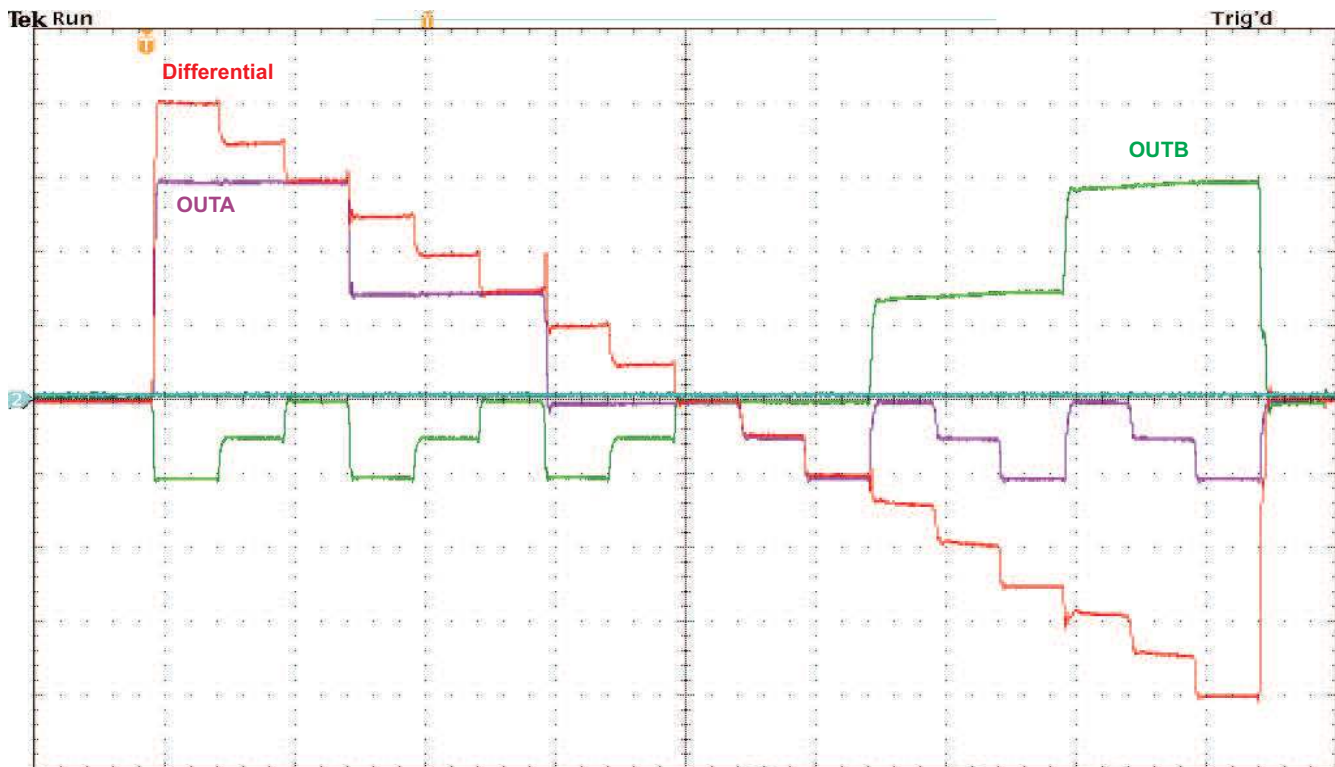

Figure 4. Output Waveform for 17-Level

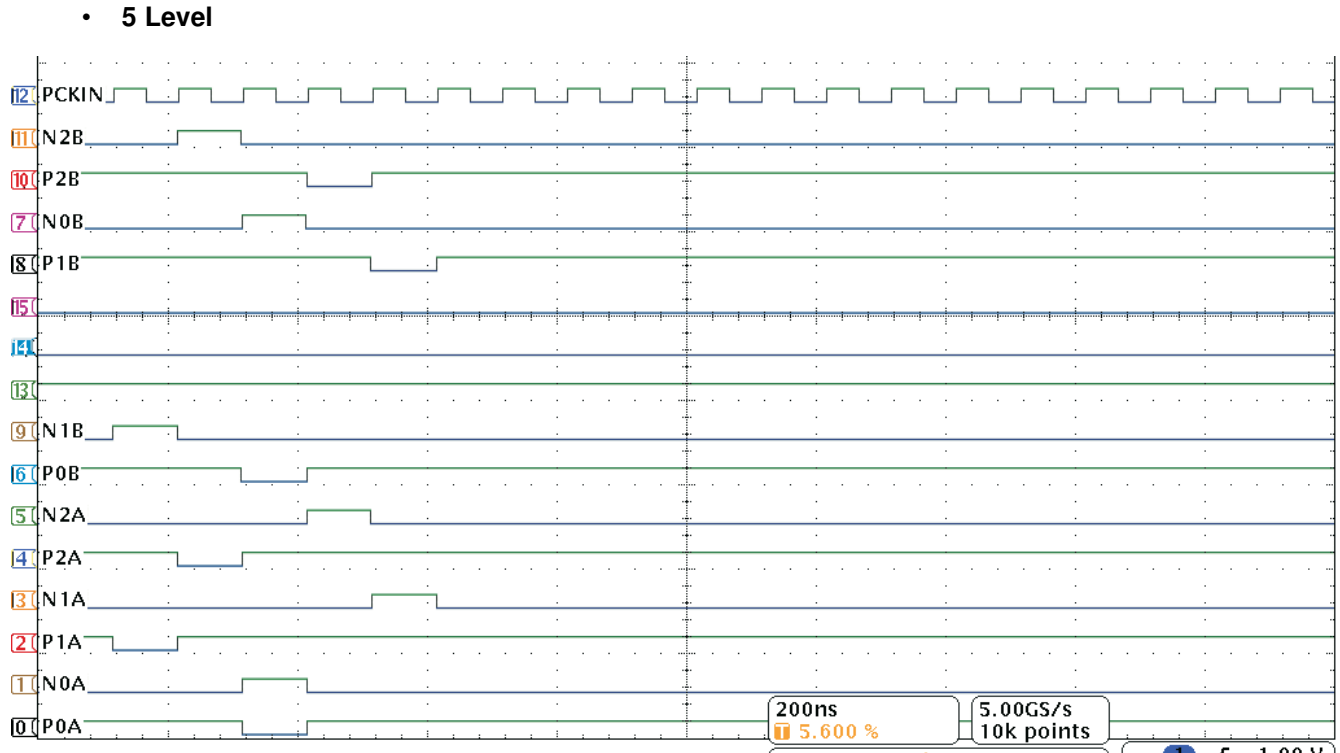

Figure 5. Input Pattern for 5-Level

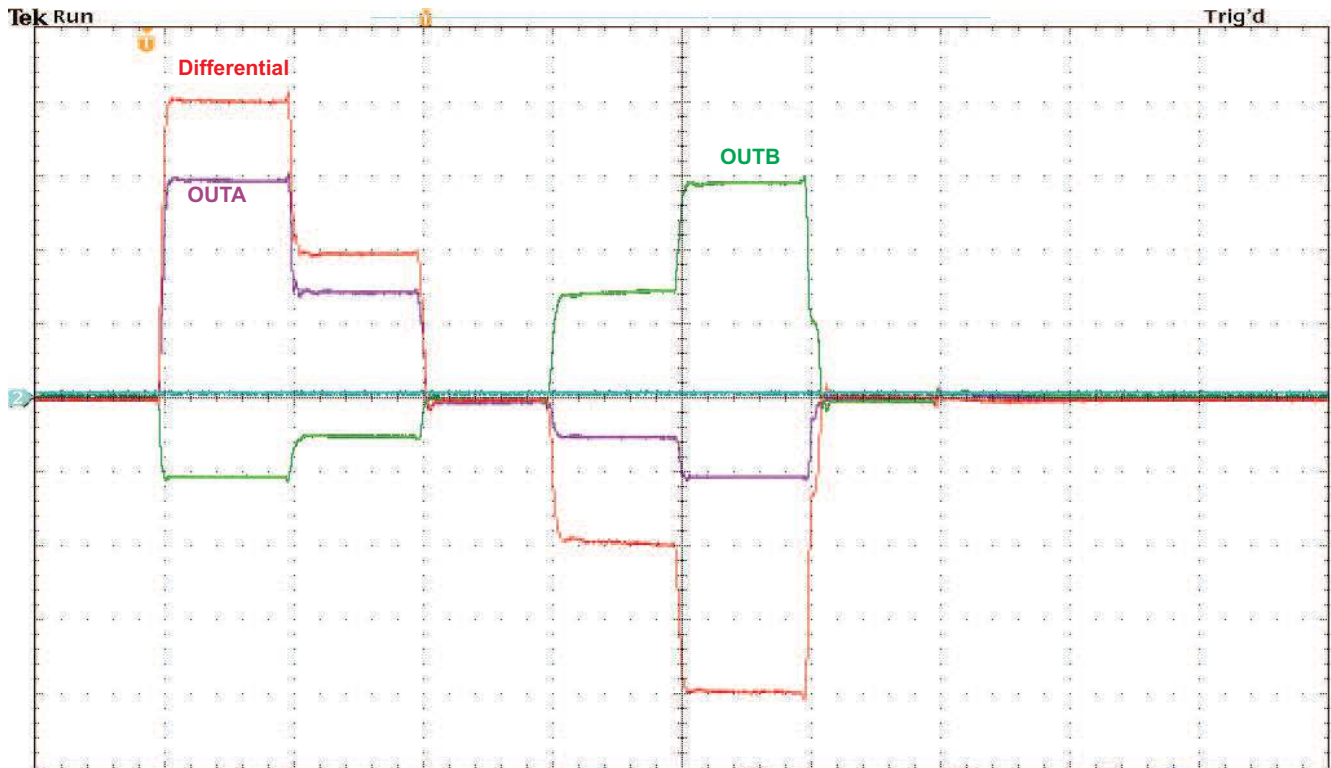

Figure 6. Output Waveform for 5-Level

• 3 Level

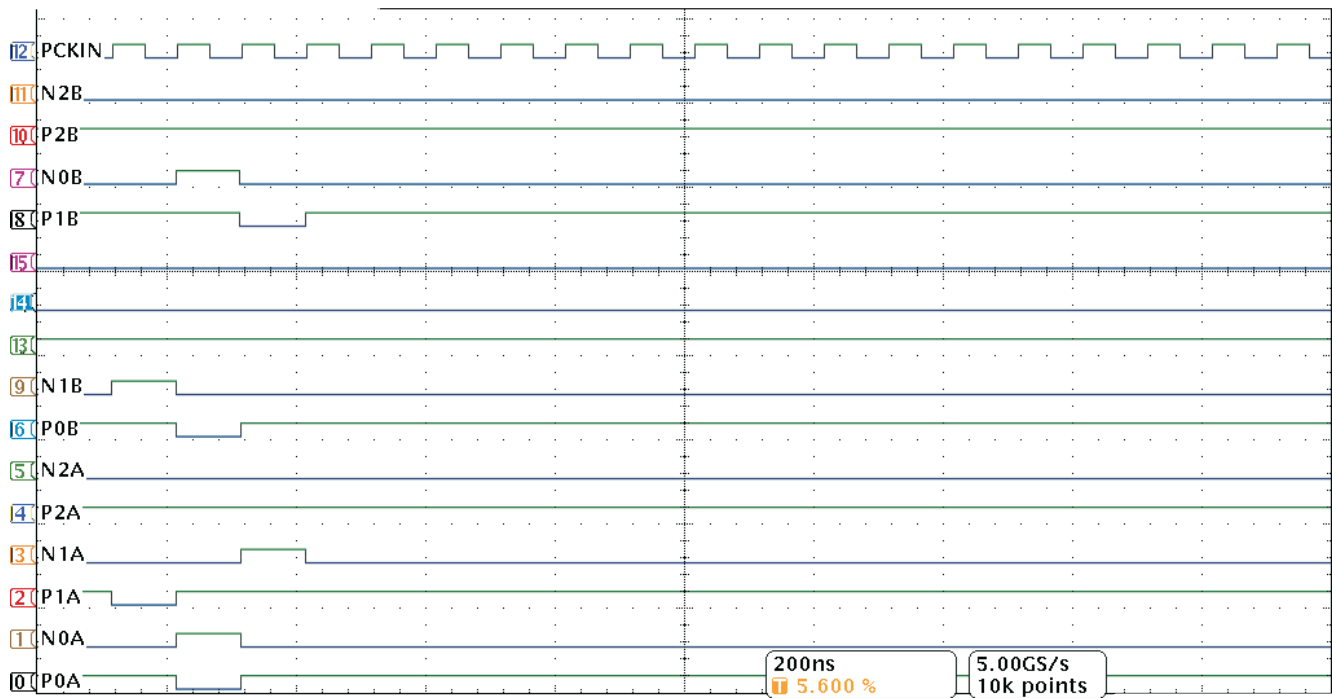

Figure 7. Input Pattern for 3-Level

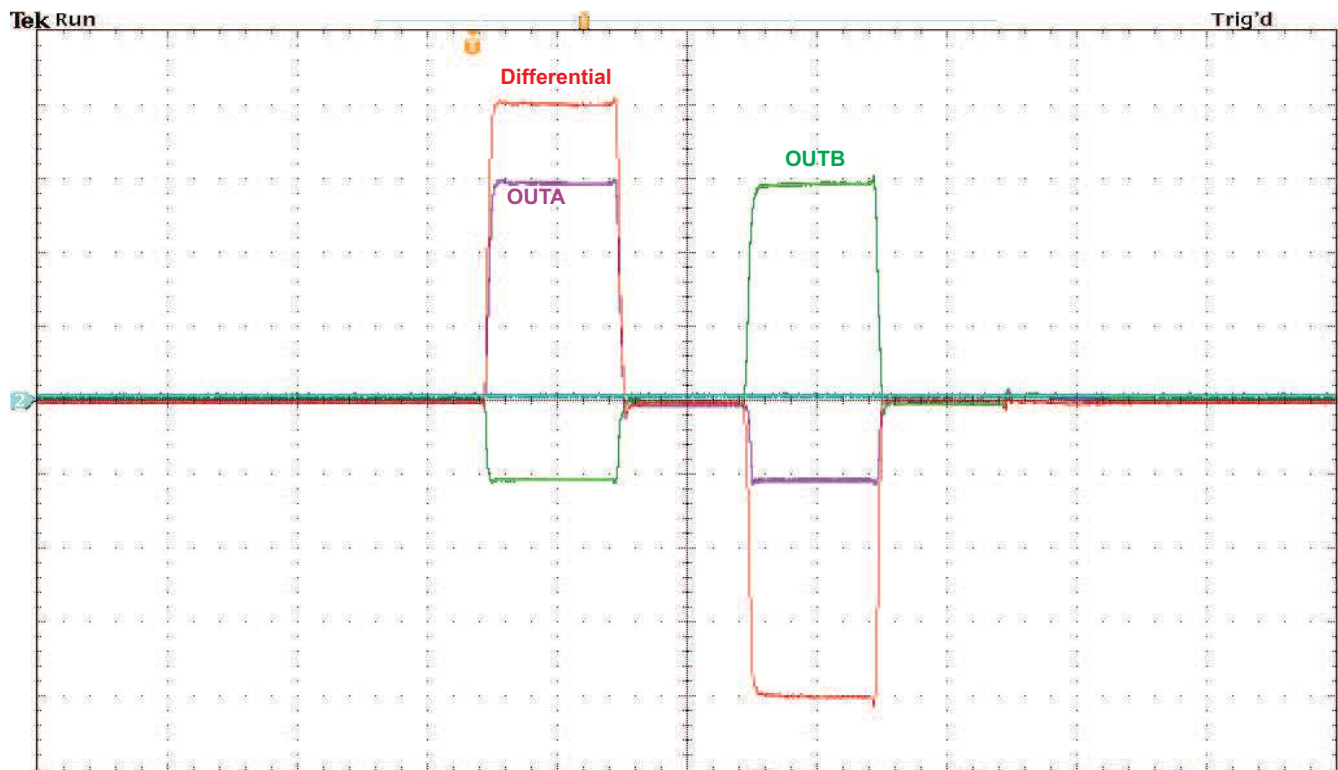

Figure 8. Output Waveform for 3-Level

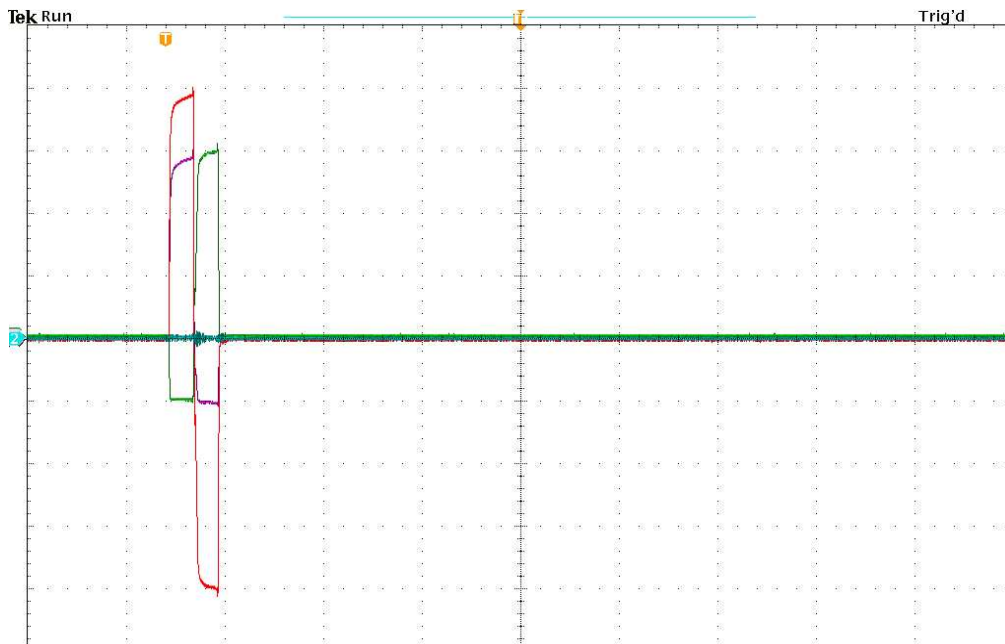

Figure 9. Output Waveform for 2-Level

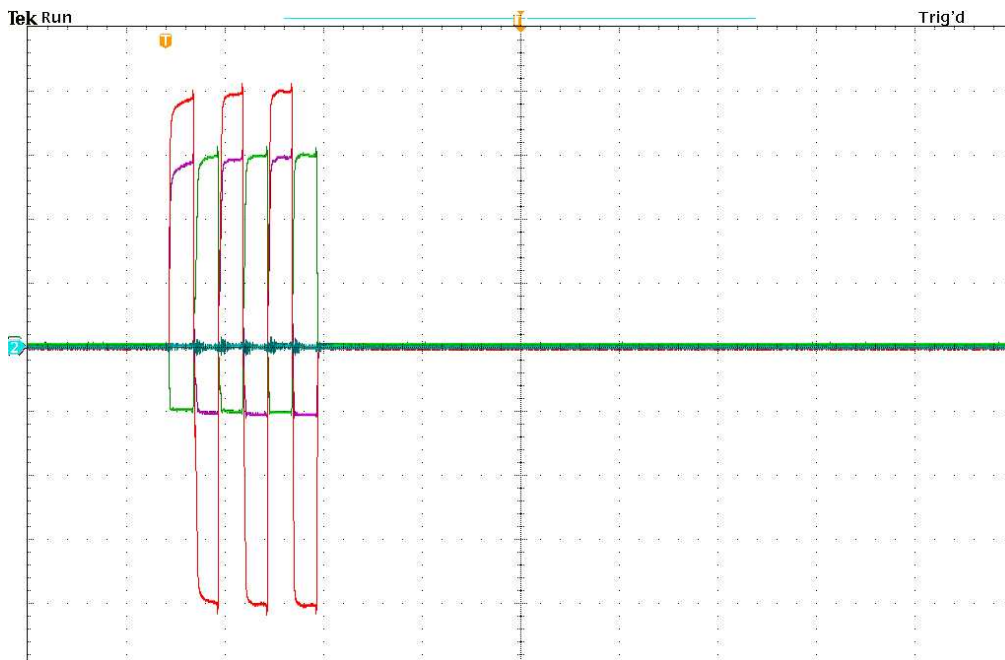

Figure 10. Output Waveform for 2-Level With Three Cycles

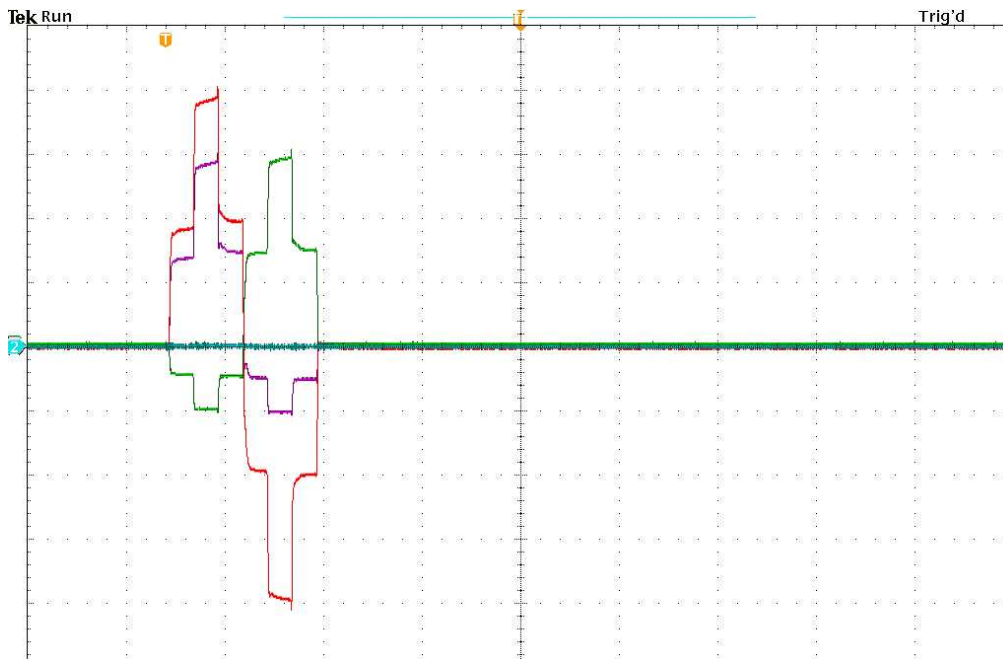

Figure 11. Output Waveform for 4-Level

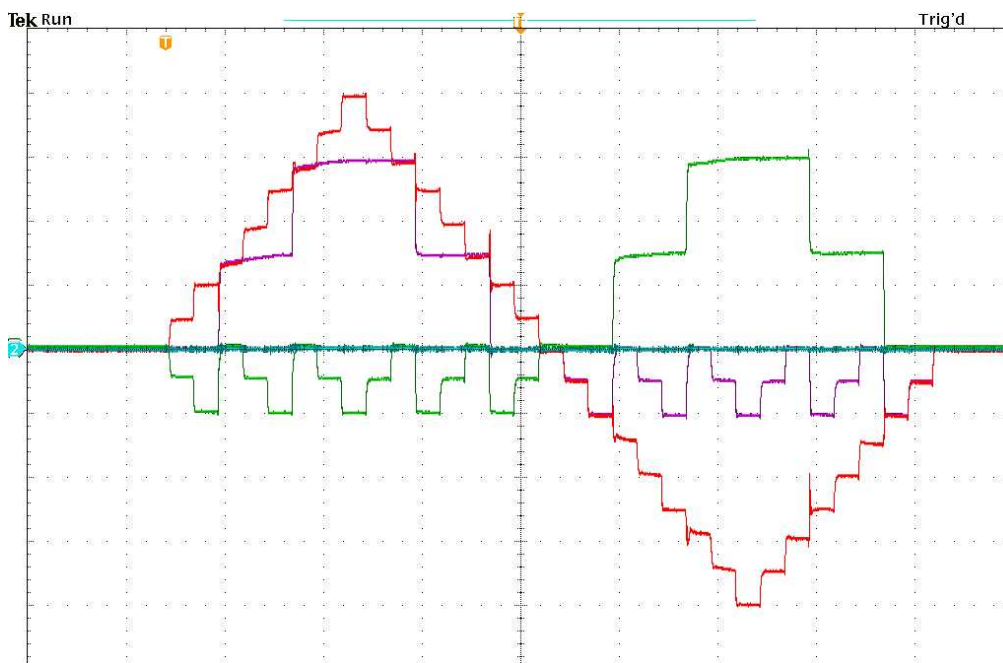

Figure 12. Output Waveform for 32-Level

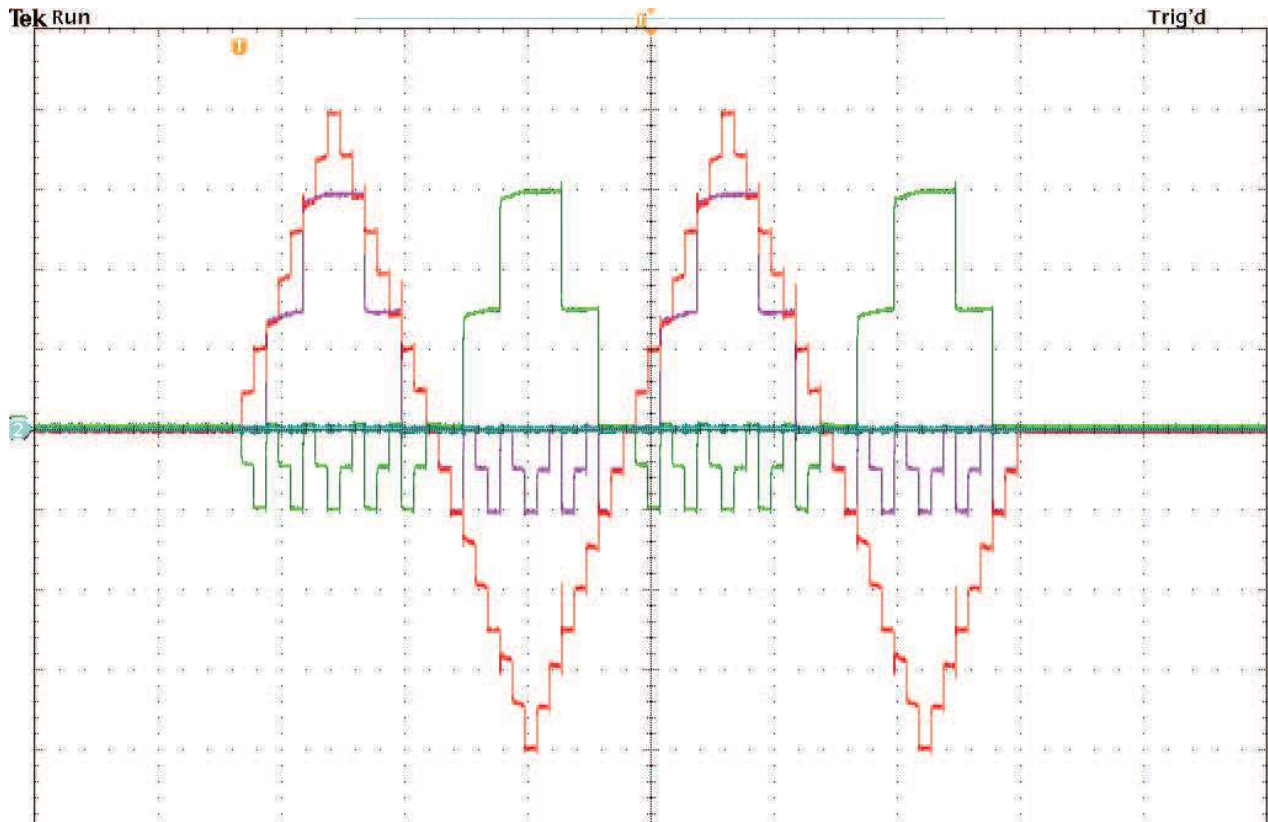

Figure 13. Output Waveform for 32-Level With Two Cycles

6 Board Configuration

Table 9. Input/Output, Power, and USB

Connector	Description
P1	External power supplies to the device
P2	+5V power supply connector.
TP5V, TEST_GND	Test points for +5V power supply.
JP20	Jumper to select +5V or FB_5V.
JP21	Select +3.3V.
JP26	Select +1.2V
JP32	External clock/On board OSC
TP1,TP2,TP3,TP4	Ground test points.
TP33V, TP12V	Test points for +3.3V and +1.2V respectively.
JP16	Short always
JP17	Short always
JP18	Short always
JP19	Short always
JP22	Default setup is to output directly/ Others is to drive thru on board transformer.
JP25	JP25: Default setup is to output directly/ Others is to drive thru on board transformer.
JP23	Open when output directly. Short when driving thru transformer
JP24	Short always
JP27	Open
JP29	Open
JP1..JP13	Test points for test pattern. They can also be used for external test patterns.
JP30/JP31	CWINA/CWINB selection.
J6	USB interface connector

Table 10. LED Indicators

Reference Designator	Power Supply
LED1/LED2	USB interface indication
LED3/LED7	FPGA alive
LED4	+5V
LED5	+3.3V
LED6	+1.2V

7 EVM Schematics

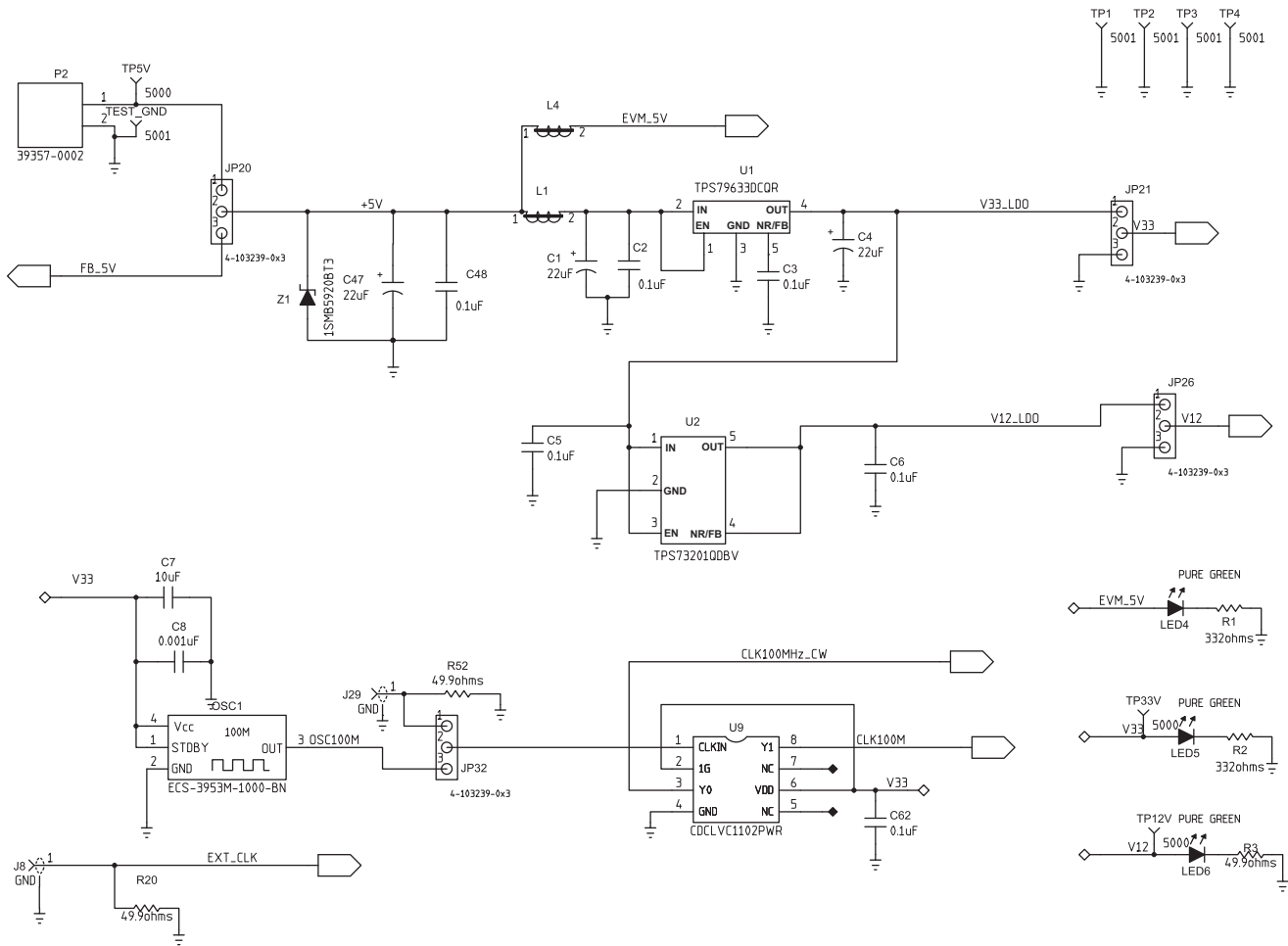
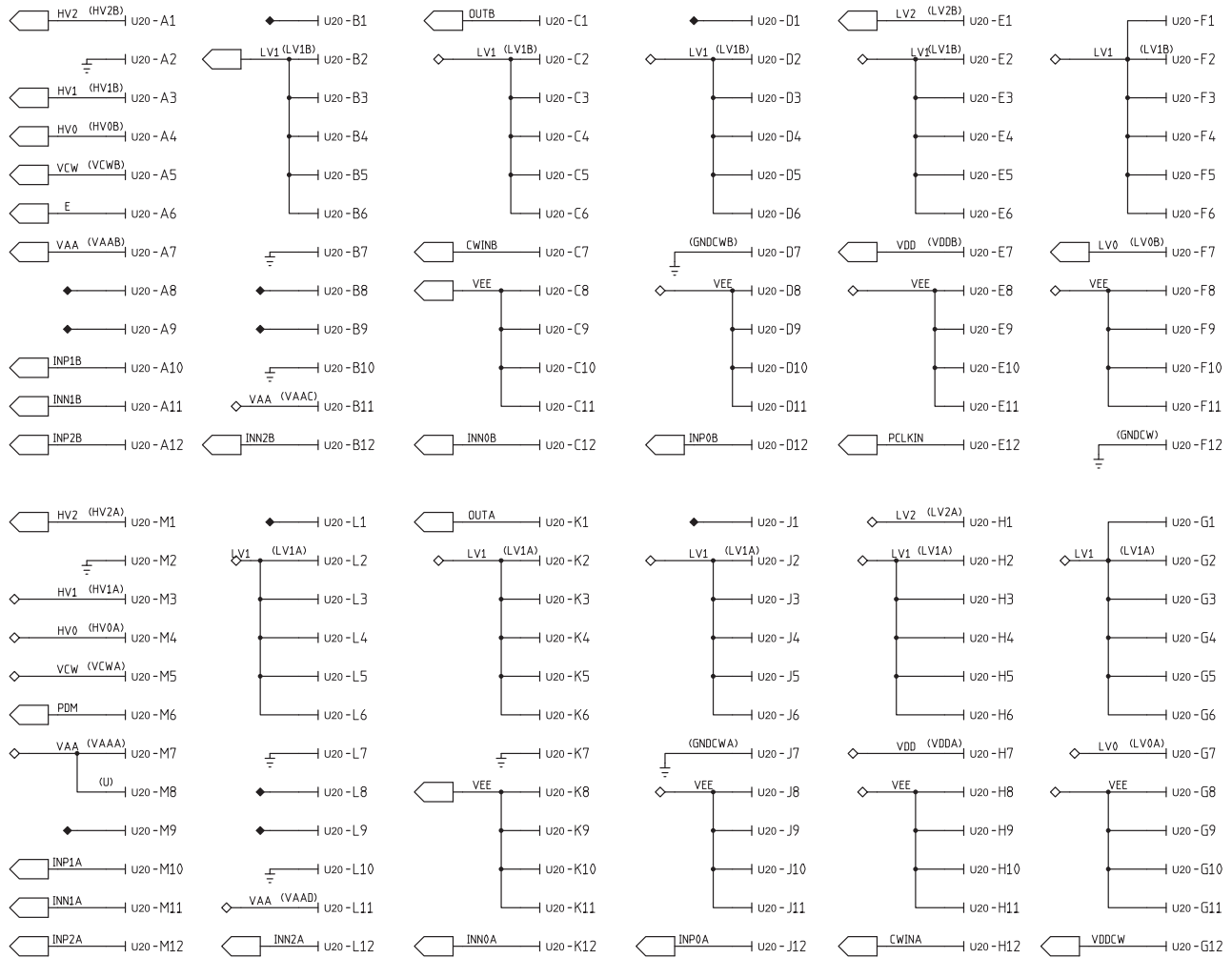
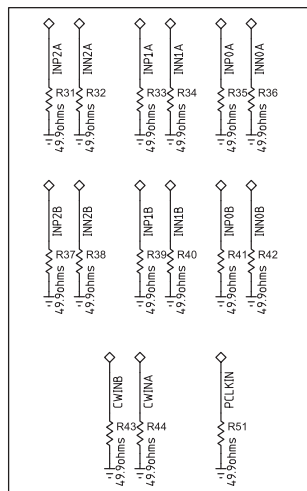

Figure 14. Schematic (1 of 8)

SOCKET or TX517



WARNING: Users may be exposed to high voltage



These resistors are not installed. They are required when an external generator is used for pattern generation.

Figure 15. Schematic (2 of 8)

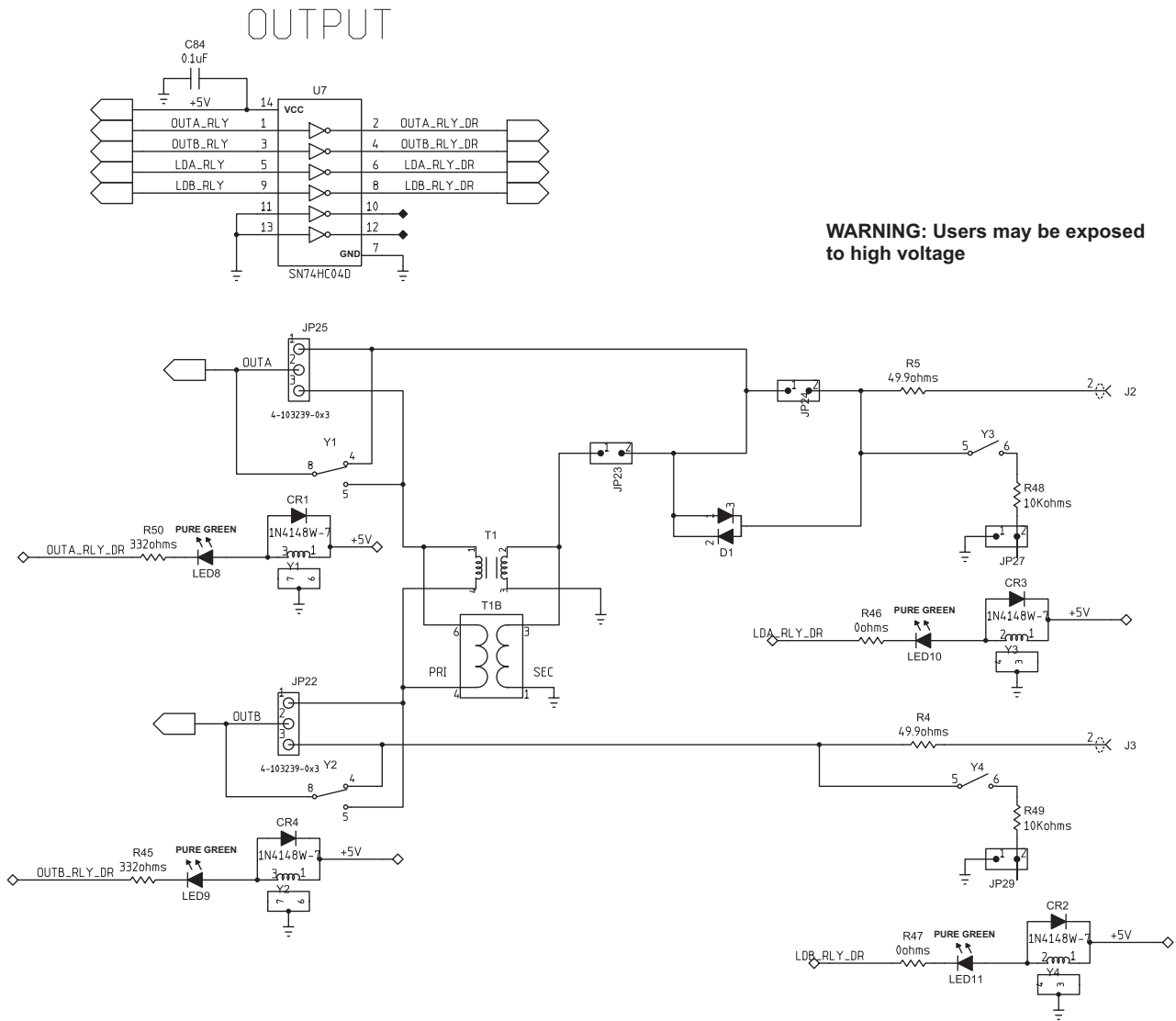
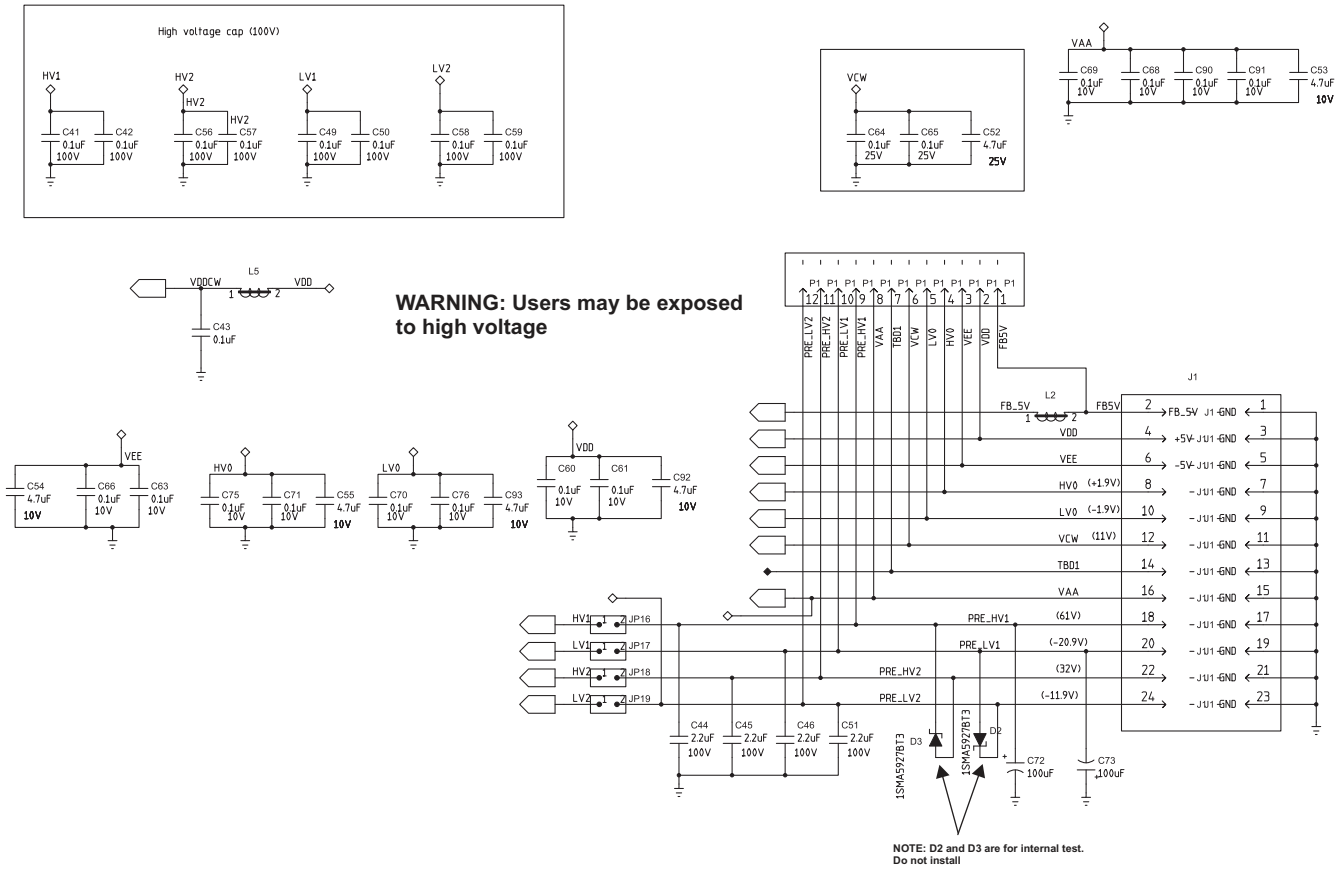

Figure 16. Schematic (3 of 8)



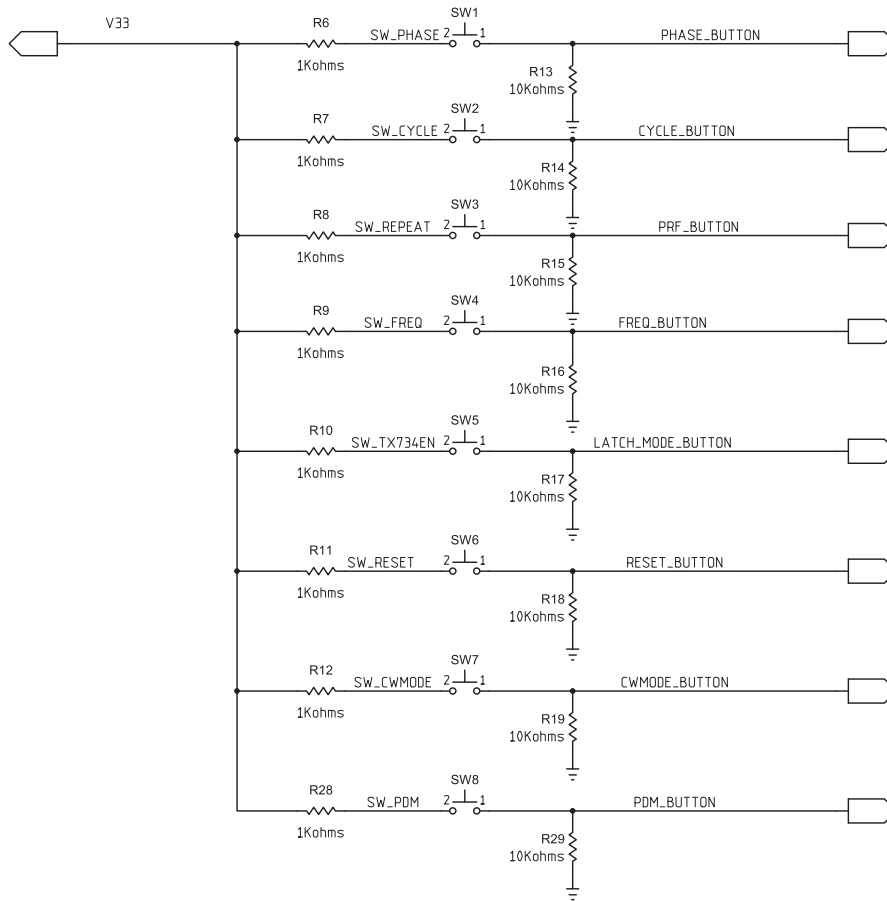

Figure 18. Schematic (5 of 8)

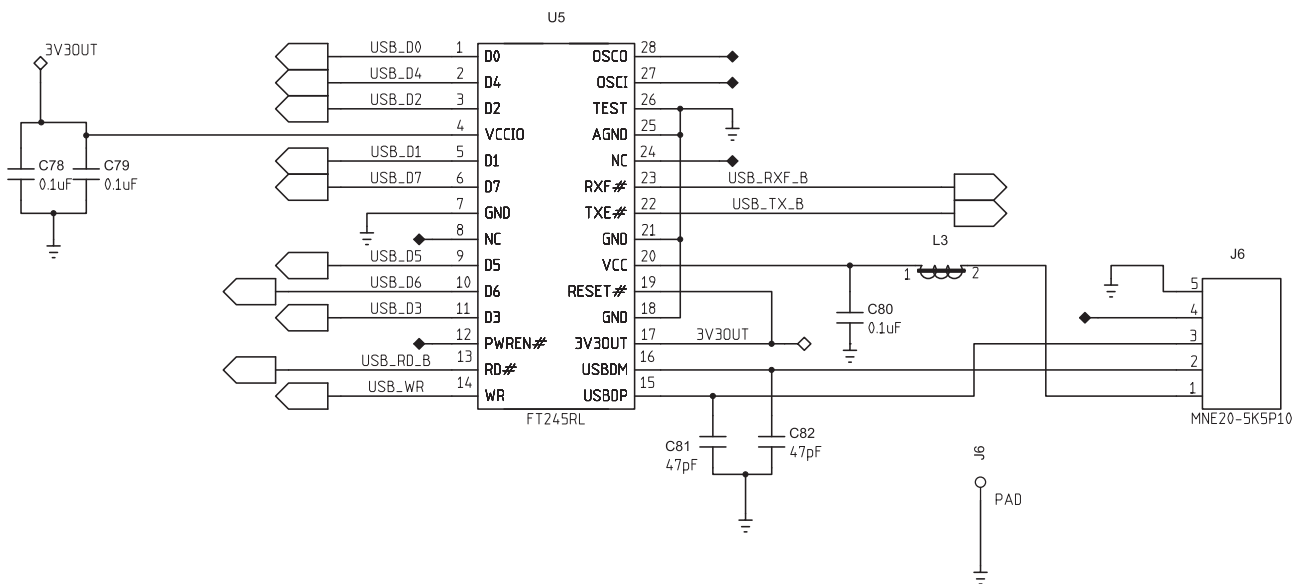

Figure 19. Schematic (6 of 8)

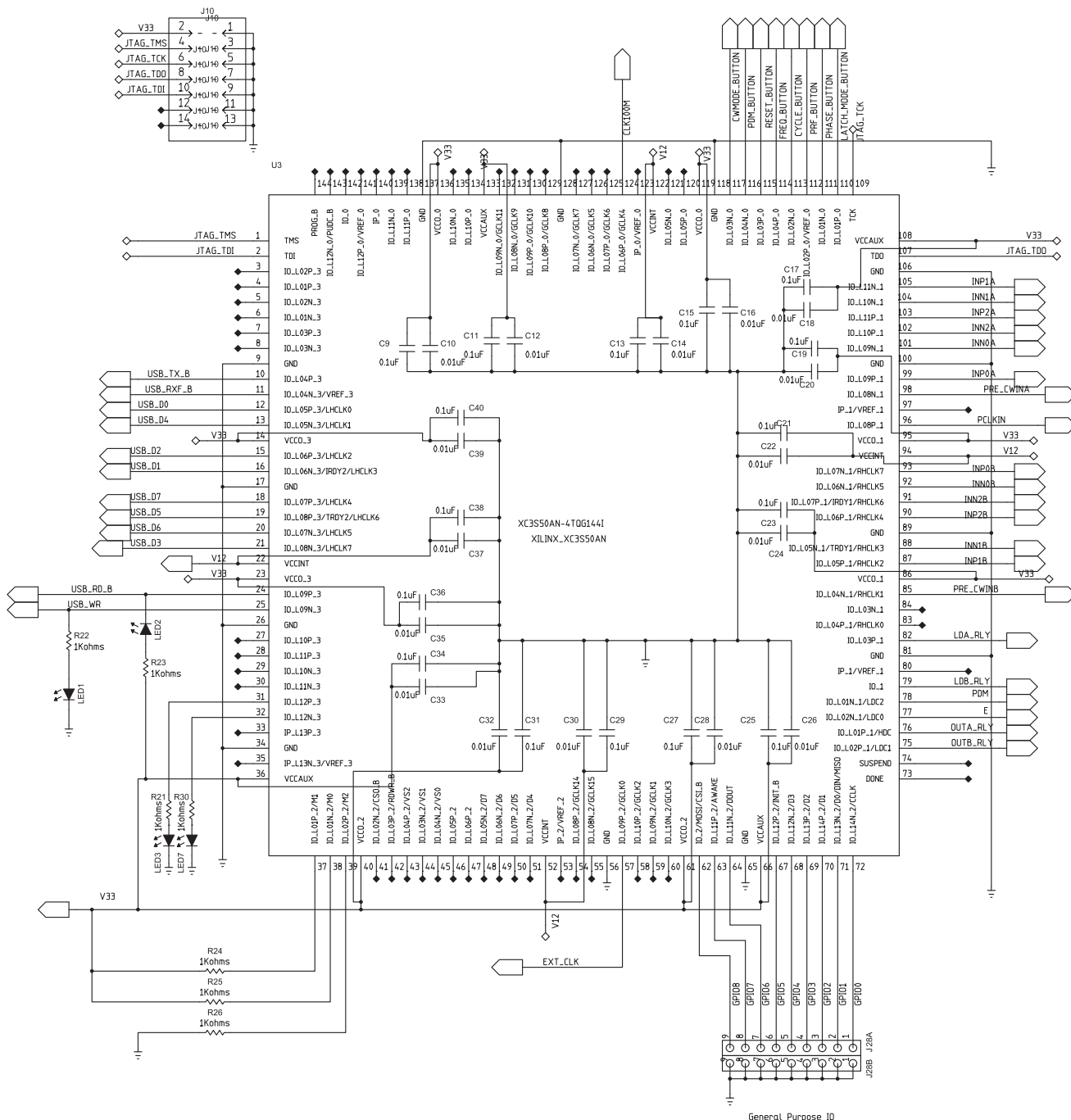

Figure 20. Schematic (7 of 8)

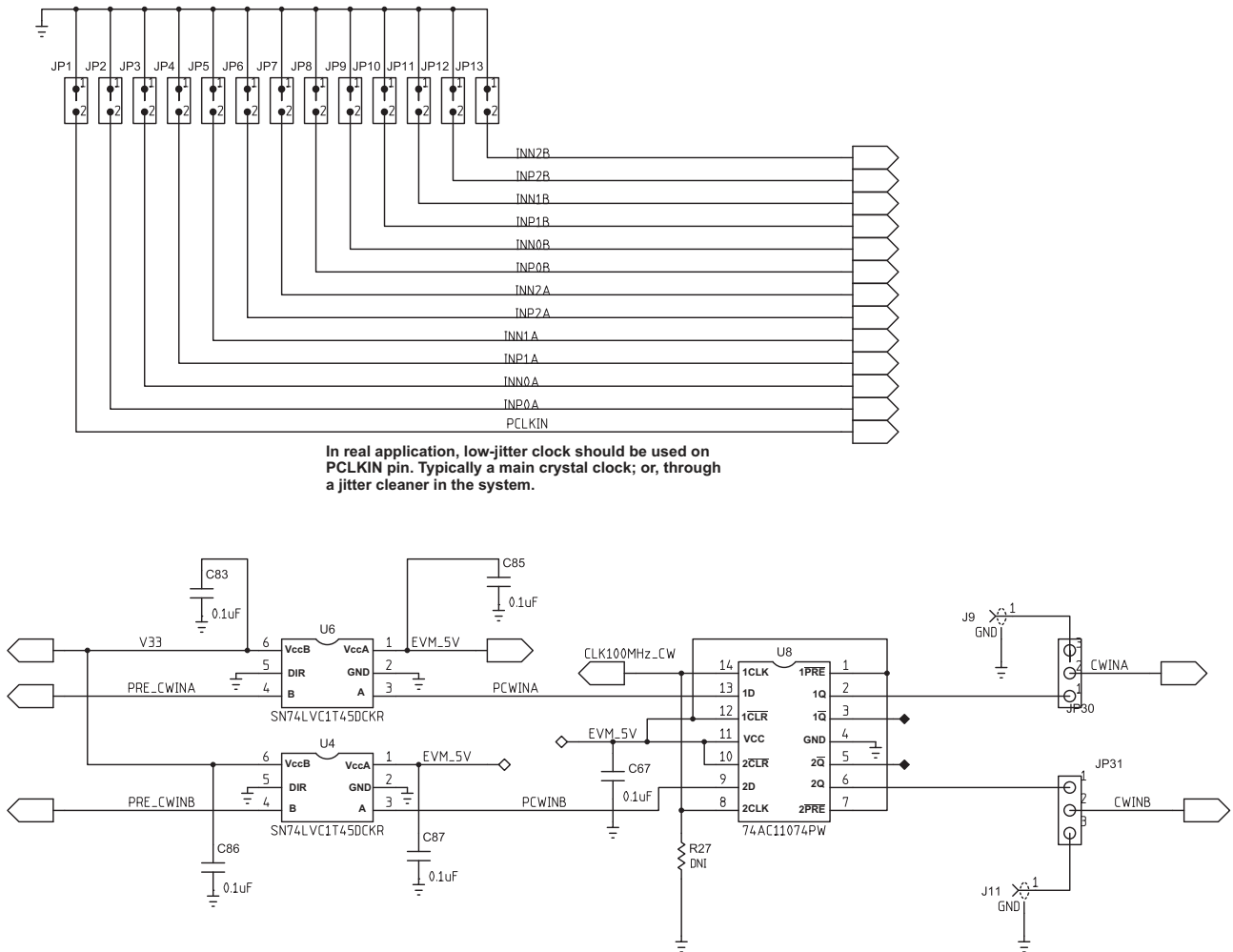

Figure 21. Schematic (8 of 8)

8 Bill of Materials
Table 11. Bill of Materials (BOM)

QTY	MFG	MFG PART#	RefDes	Description	Value or Function
1	TX517	TX517	U20	Ultrasound Transmitter	TX517 transmitter (TI Provide)
2	PANASONIC	EEUFC2A101L	C72, C73	CAP,RAD,ELEC	CAP,THRU,ELE,100uf,100V,20%
16	AVX	0402YC103KAT2A	C10, C12, C14, C16, C18, C20, C22, C24, C26, C28, C30, C32, C33, C35, C37, C39	CAP,SMT,0402	CAPACITOR,SMT,0402,CERAMIC,10000pF,16V,10%,X7R
13	AVX	0402YC104KAT2A	C43, C60, C61, C63, C66, C68, C69, C70, C71, C75, C76, C90, C91	CAP,SMT,0402	CAPACITOR,SMT,0402,CER,16V,10%,0.1uF
31	KEMET	C0402C104K8PAC	C2, C3, C5, C6, C9, C11, C13, C15, C17, C19, C21, C23, C25, C27, C29, C31, C34, C36, C38, C40, C48, C62, C67, C78, C79, C80, C83, C84, C85, C86, C87	CAP,SMT,0402	CAPACITOR,SMT,0402,CER,0.1uF,10V,10%,X5R
1	PANASONIC	ECJ-0EB1H102K	C8	CAP,SMT,0402	CAPACITOR,SMT,0402,CER,1000pF,50V,10%,X7R
2	PANASONIC	ECJ-0EC1H470J	C81, C82	CAP,SMT,0402	CAPACITOR,SMT,0402,CER,47pF,50V,5%,NPO
2	AVX	06033C104JAT2A	C64, C65	CAP,SMT,0603	CAPACITOR,SMT,0603,CERAMIC,0.1uF,25V,5%,X7R
1	CAPAX	0603X475J250SW	C52	CAP,SMT,0603	CAPACITOR,SMT,0603,CERAMIC,4.7uF,25V,5%,X7R
1	TAIYO YUDEN	JMK107BJ106MA-T	C7	CAP,SMT,0603	CAPACITOR,SMT,0603,CERAMIC,10uF,6.3V,20%,X5R
5	TAIYO YUDEN	LMK107BJ475KA-T	C53, C54, C55, C92, C93	CAP,SMT,0603	CAPACITOR,SMT,0603,CERAMIC,4.7uF,10V,10%,X5R
8	AVX	08051C104KAZ2A	C41, C42, C49, C50, C56, C57, C58, C59	CAP,SMT,0805	CAPACITOR,SMT,0805,CERAMIC,0.1uF,100V,10%
4	TAIYO YUDEN	HMK325BJ225KN	C44, C45, C46, C51	CAP,SMT,1210	CAPACITOR,SMT,1210,CERAMIC,2.2uF,100V,10%,X7R
2	VISHAY	593D226X9016C2T	C1, C4	CAP,SMT,TANT	CAP,TAN,SMT,EIA-C,16V,10%, 22uF
1	AVX	TPSC226K016R0375	C47	CAPACITOR,SMT,TANT	10%, 16V, 22uF
2	JOHNSON COMPONENTS	142-0711-826	J2, J3	CON,SMA,SMT	SMA JACK,END LAUNCH,A068,062PCB,BRASS/NICKEL
1	ADVANCED CONNECTEK	MNE20-5K5P10	J6	CONN,SMT,5P	MINI-AB USB OTG RECEPTACLE R/A SMT TYPE
4	AMPHENOL	901-144-8	J8, J9, J11, J29	CONNECTOR,SMA	SMA COAX STRAIGHT PCB CURRENT P/N IS 901-144-8RFX
1	Customer Supply	DO NOT INSTALL	T1	Transformer	Do Not Install
4	DIODES INC.	1N4148W-7	CR1, CR2, CR3, CR4	DIODE,SMT,2P	DIODE,SMT,SWITCHING,1N4148
1	DIODES INC.	MMBD3004S-7-F	D1	DIODE,SMT,3P	DIODE SWITCH 300V 350MW SOT23-3
5	STEWART	HI0805R800R-00	L1, L2, L3, L4, L5	FERRITE BEAD,SMT,2P	
1	SAMTEC	IPL-112-01-S-D-K	J1	HEADER,THP,24P	HEADER,THP,24P,MALE,2X12,100LS,.120TL
1	MOLEX	39357-0002	P2	HEADER,THRU,2P	HEADER, THRU, POWER, 2P,3.5MM, EUROSTYLE
1	SPC TECH	8431-1x12 (DNI)	P1	HEADER,THU,12P	HEADER,THU,MALE,0.1LS,12P,1X12,335H,120TL,(Do Not Install)
1	MOLEX	87831-1420	J10	HEADER,THU,14P	HEADER,MALE,14POS,2 ROWS,2mm LS,15u,LF,TL=098
2	SPC TECH	8431-1x9	J28A, J28B	HEADER,THU,9P	HEADER,THU,MALE,0.1LS,9P,1X9,335H,120TL

Table 11. Bill of Materials (BOM) (continued)

QTY	MFG	MFG PART#	RefDes	Description	Value or Function
21	TYCO ELECTRONICS	4-103239-0x2	JP1, JP2, JP3, JP4, JP5, JP6, JP7, JP8, JP9, JP10, JP11, JP12, JP13, JP16, JP17, JP18, JP19, JP23, JP24, JP27, JP29	HEADER,THU,JUMPER	MALE,2PIN,,100CC MAKE FROM 4-103239-0x2
8	TYCO ELECTRONICS	4-103239-0x3	JP20, JP21, JP22, JP25, JP26, JP30, JP31,JP32	HEADER,THU,JUMPER	MAKE FROM 4-103239-0
2	TI	SN74LVC1T45DCKR	U4, U6	IC,SMT,6P	SINGLE BIT DUAL SUPPLY BUS TRANSCEIVER
1	TI	SN74HC04D	U7	IC,SMT,SOIC-14N	HEX INVERTER
1	TI	TPS79633DCQR	U1	IC,SMT,SOT223-6	ULTRALOW-NOISE HI PSRR FAST RF 1-A LDO LINEAR REGULATOR,3.3V
1	TI	TPS73201QDBV	U2	IC,SMT,SOT23-5	CAP-FREE NMOS 250-mA LOW DROPOUT REGULATOR
1	FUTURE TECHNOLOGY DEVICE INT.	FT245RL	U5	IC,SMT,SSOP-28	USB FIFO IC INCORPORATE FTDICHIP-ID SECURITY DONGLE
1	XILINX	XC3S50AN-4TQG144I	U3	IC,SMT,TQFP-144	XILINX SPARTAN-3AN 144QFP
1	TI	74AC11074PW	U8	IC,SMT,TSSOP-14	DUAL POS-EDGE-TRIG D-TYPE FLIP-FLOP W CLEAR AND PRESET,PW-14
1	TI	CDCLVC1102PWR	U9	IC,SMT,TSSOP-8	3.3V AND 2.5V LVCMOS HIGH PERF CLOCK BUFFER FAMILY
7	PANASONIC	LNJ308G8PRA	LED4, LED5, LED6, LED8, LED9, LED10, LED11	LED,SMT,0603	LED,SMT,0603,PURE GREEN,2.03V
4	KINGBRIGHT	KP-2012ID	LED1, LED2, LED3, LED7	LED,SMT,2P	LED,RED,SMT,0805
1	ECS	ECS-3953M-1000-BN	OSC1	OSCILLATOR,SMT,4P	OSC,SMT,3.3V,50ppm,-40~85C,5nS,100.000 MHz
2	*COTO TECHNOLOGY	9402-05-20	Y3, Y4	RELAY,SMT,6P	SPST,SMT,50 OHM,5V,0.5A,200 OHM COIL,,J-LEAD (Not Install)
2	*COTO TECHNOLOGY	2911-05-321	Y1, Y2	RELAY,THRU,7P	RELAY,THRU,7P,RR,SPDT,1FC,5V,0.25A,230R COIL,,COAXIAL SHIELD (Not Install)
15	PANASONIC	ERJ-2RKF1001X	R6, R7, R8, R9, R10, R11, R12, R21, R22, R23, R24, R25, R26, R28, R30	RES,SMT,0402	RESISTOR,SMT,0402,1.00K,1%,1/16W
8	PANASONIC	ERJ-2RKF1002X	R13, R14, R15, R16, R17, R18, R19, R29	RES,SMT,0402	RESISTOR,SMT,0402,10.0K,1%,1/16W
7	PANASONIC	ERJ-2RKF3320X	R1, R2, R3, R45, R46, R47, R50	RES,SMT,0402	RESISTOR,SMT,0402,332 OHM,1%,1/16W
2	PANASONIC	ERJ-2RKF49R9X	R20, R52	RES,SMT,0402	RESISTOR,SMT,0402,49.9 OHM,1%,1/16W,
2	VISHAY	CRCW08051002F	R48, R49	RES,SMT,0805	RESISTOR,SMT,0805,THICK FILM,1%,1/8W,10.0K
2	VISHAY	CRCW251249R9FKEG	R4, R5	RESISTOR,SMT,2512	RESISTOR,SMT,2512,THICK FILM,49.9 OHM,1%,1W
8	ITT INDUSTRIES	PTS635SK25SM	SW1, SW2, SW3, SW4, SW5, SW6, SW7, SW8	SWITCH,SMT,2P	SWITCH,SMT,2P,SPST-NO,2.5mm HEIGHT,MOM,RECTANGULAR,0.05A,12V
3	KEYSTONE ELECTRONICS	5000	TP12V, TP33V, TP5V	TESTPOINT,THU,1P	TESTPOINT,THU,MINIATURE,0.1LS,120TL, RED
5	KEYSTONE ELECTRONICS	5001	TP1, TP2, TP3, TP4, TEST_GND	TESTPOINT,THU,1P	TESTPOINT,THU,MINIATURE,0.1LS,120TL, BLACK
2	ON SEMI	1SMA5927BT3	D2, D3	ZENER DIODE,SMT,SMA	ZENER DIODE,12V,SMT,SMA,1.5W (Not Installed)
1	ON SEMI	1SMB5920BT3	Z1	ZENER DIODE,SMT,SMB	ZENER DIODE,6.2V,SMT,SMB,3W
2	TYCO	50935	Y1, Y2	SOCKET PIN - INSTALL 1ST	DIA_038, PIN_013-020, EXP_146, B125

Table 11. Bill of Materials (BOM) (continued)

QTY	MFG	MFG PART#	RefDes	Description	Value or Function
1	PANASONIC	ERJ-2RKF49R9X	R27	RES,SMT,0402	RESISTOR,SMT,0402,49.9 OHM,1%,1/16W(Not Install)
1	Customer Supply	DO NOT INSTALL	T1B	Transformer	DO NOT INSTALL
15	PANASONIC	ERJ-2RKF49R9X(DNI)	R31, R32, R33, R34, R35, R36, R37, R38, R39, R40, R41, R42, R43, R44, R51	RES,SMT,0402	RESISTOR,SMT,0402,49.9 OHM,1%,1/16W, Uninstall
4	KEYSTONE ELECTRONICS	24436K-ND		STANDOFF HEX M3 THR ALUM 18MM	STANDOFF HEX M3 THR ALUM 18MM
4	KEYSTONE ELECTRONICS	29311K-ND		SCREW STEEL M3 THR 6MM	SCREW STEEL M3 THR 6MM
	TE Connectivity	1658621-5		Cover for P1	Snap latch into place. Install as needed
SPECIAL NOTES AND INSTRUCTIONS					

9 PCB Layouts

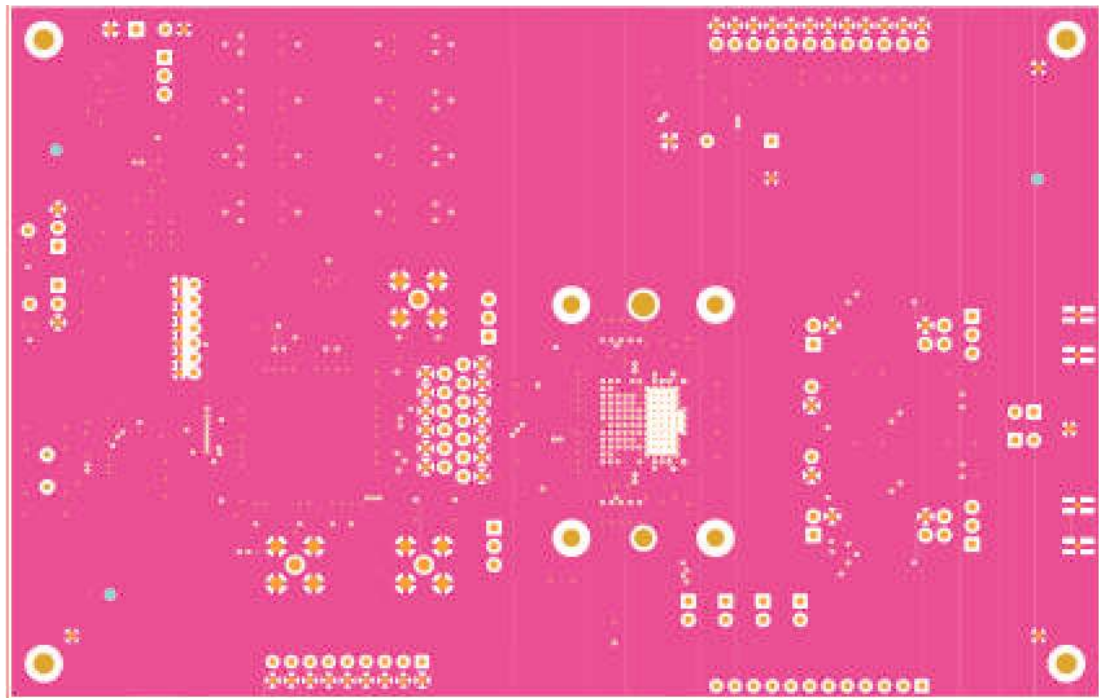
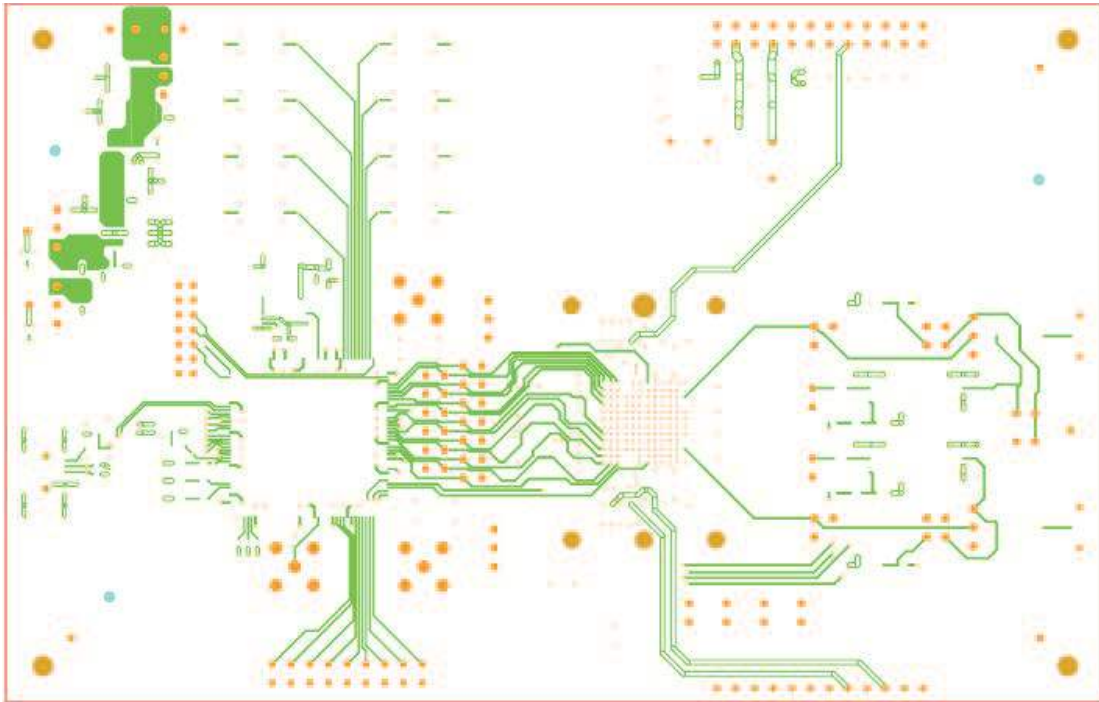

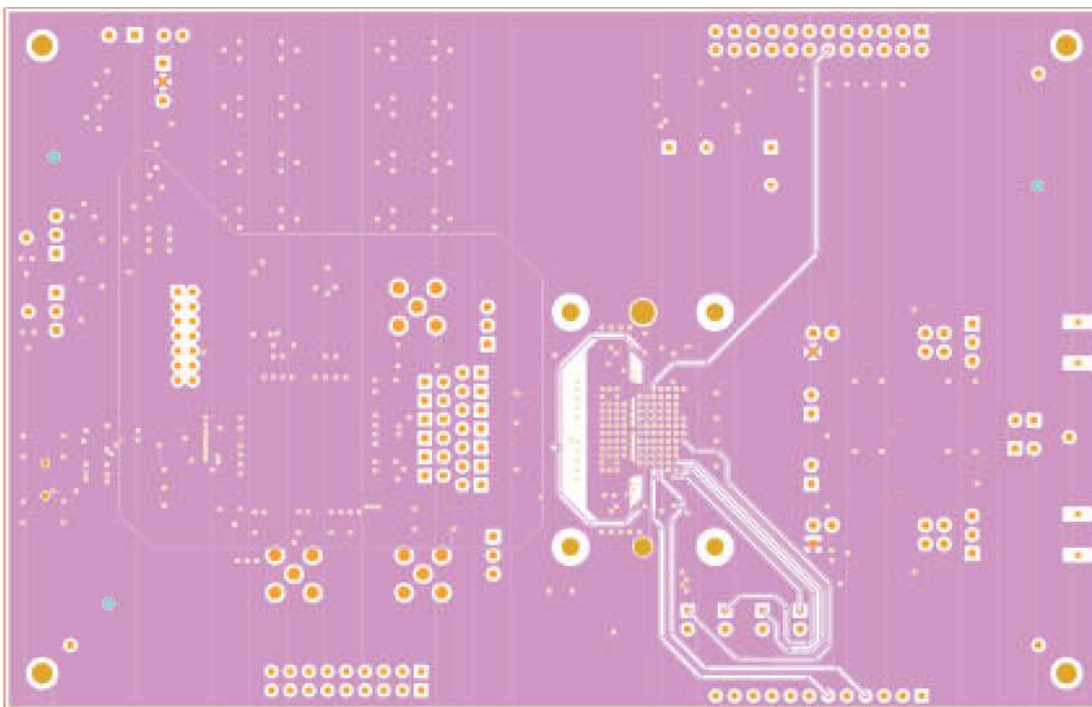
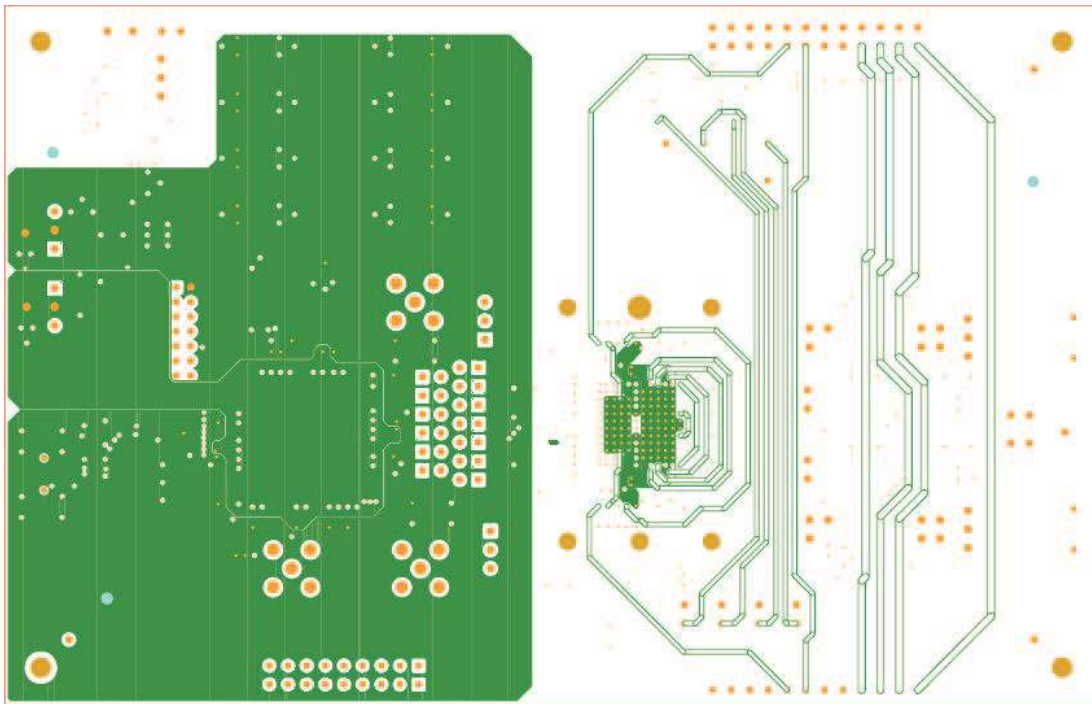

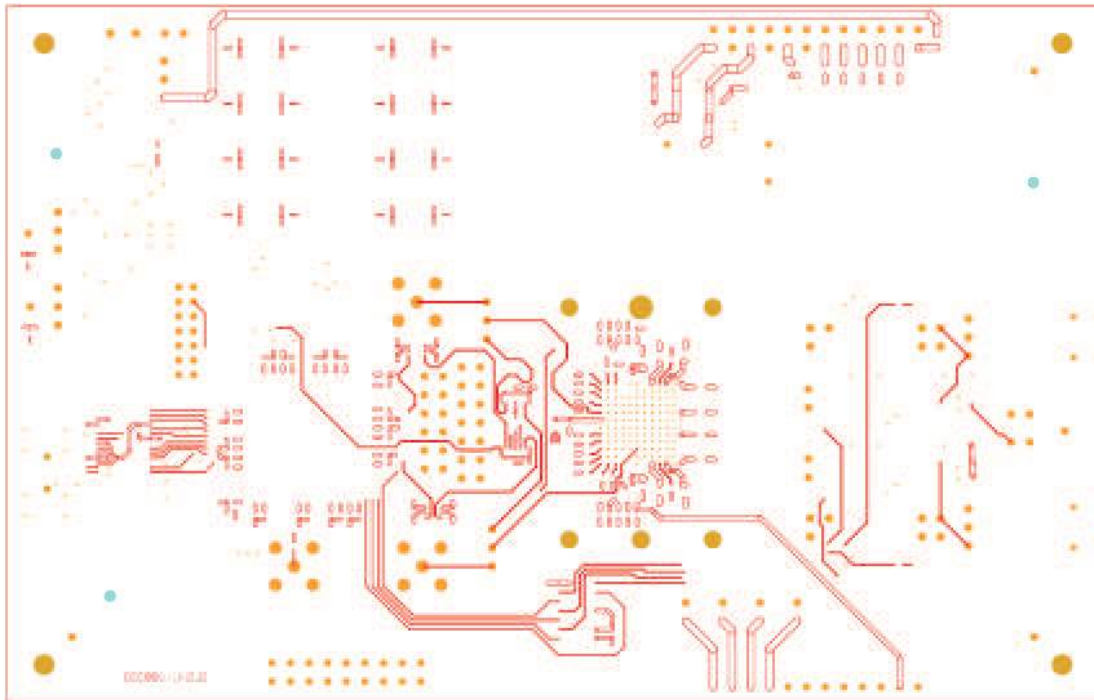
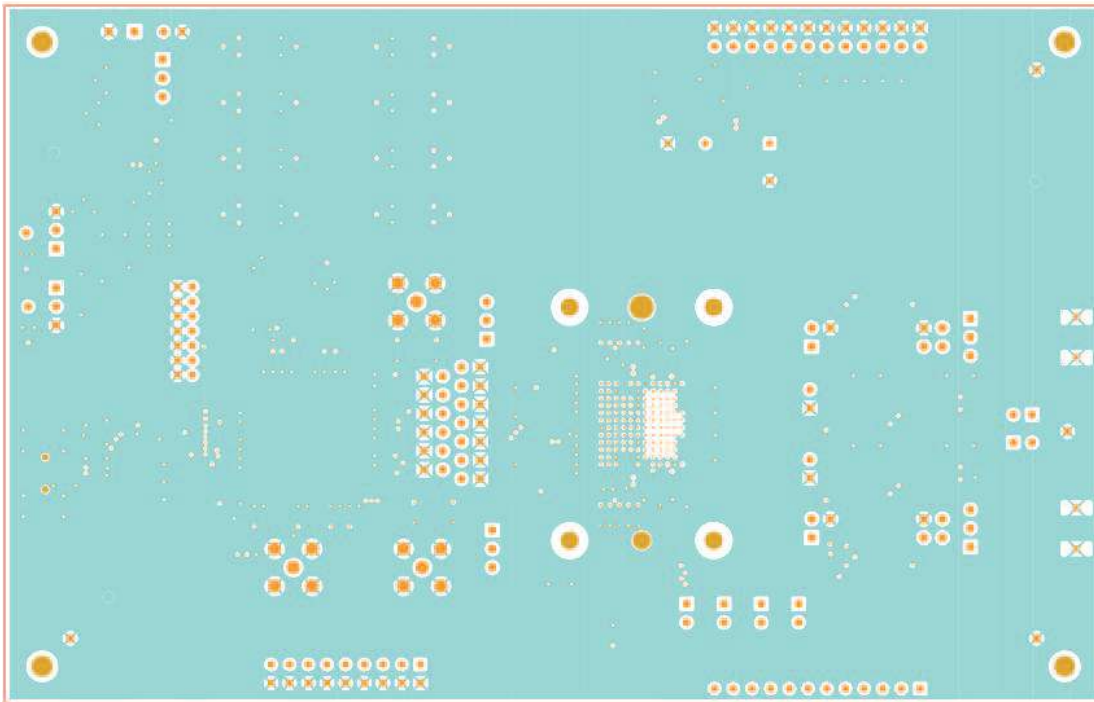

Revision History

NOTE: Page numbers for previous revisions may differ from page numbers in the current version.

Changes from B Revision (December 2011) to C Revision **Page**

- Changed *Power-Up Indications* image. 6

STANDARD TERMS FOR EVALUATION MODULES

1. *Delivery:* TI delivers TI evaluation boards, kits, or modules, including any accompanying demonstration software, components, and/or documentation which may be provided together or separately (collectively, an "EVM" or "EVMs") to the User ("User") in accordance with the terms set forth herein. User's acceptance of the EVM is expressly subject to the following terms.
 - 1.1 EVMs are intended solely for product or software developers for use in a research and development setting to facilitate feasibility evaluation, experimentation, or scientific analysis of TI semiconductor products. EVMs have no direct function and are not finished products. EVMs shall not be directly or indirectly assembled as a part or subassembly in any finished product. For clarification, any software or software tools provided with the EVM ("Software") shall not be subject to the terms and conditions set forth herein but rather shall be subject to the applicable terms that accompany such Software
 - 1.2 EVMs are not intended for consumer or household use. EVMs may not be sold, sublicensed, leased, rented, loaned, assigned, or otherwise distributed for commercial purposes by Users, in whole or in part, or used in any finished product or production system.
2. *Limited Warranty and Related Remedies/Disclaimers:*
 - 2.1 These terms do not apply to Software. The warranty, if any, for Software is covered in the applicable Software License Agreement.
 - 2.2 TI warrants that the TI EVM will conform to TI's published specifications for ninety (90) days after the date TI delivers such EVM to User. Notwithstanding the foregoing, TI shall not be liable for a nonconforming EVM if (a) the nonconformity was caused by neglect, misuse or mistreatment by an entity other than TI, including improper installation or testing, or for any EVMs that have been altered or modified in any way by an entity other than TI, (b) the nonconformity resulted from User's design, specifications or instructions for such EVMs or improper system design, or (c) User has not paid on time. Testing and other quality control techniques are used to the extent TI deems necessary. TI does not test all parameters of each EVM. User's claims against TI under this Section 2 are void if User fails to notify TI of any apparent defects in the EVMs within ten (10) business days after delivery, or of any hidden defects with ten (10) business days after the defect has been detected.
 - 2.3 TI's sole liability shall be at its option to repair or replace EVMs that fail to conform to the warranty set forth above, or credit User's account for such EVM. TI's liability under this warranty shall be limited to EVMs that are returned during the warranty period to the address designated by TI and that are determined by TI not to conform to such warranty. If TI elects to repair or replace such EVM, TI shall have a reasonable time to repair such EVM or provide replacements. Repaired EVMs shall be warranted for the remainder of the original warranty period. Replaced EVMs shall be warranted for a new full ninety (90) day warranty period.
3. *Regulatory Notices:*
 - 3.1 *United States*
 - 3.1.1 *Notice applicable to EVMs not FCC-Approved:*

FCC NOTICE: This kit is designed to allow product developers to evaluate electronic components, circuitry, or software associated with the kit to determine whether to incorporate such items in a finished product and software developers to write software applications for use with the end product. This kit is not a finished product and when assembled may not be resold or otherwise marketed unless all required FCC equipment authorizations are first obtained. Operation is subject to the condition that this product not cause harmful interference to licensed radio stations and that this product accept harmful interference. Unless the assembled kit is designed to operate under part 15, part 18 or part 95 of this chapter, the operator of the kit must operate under the authority of an FCC license holder or must secure an experimental authorization under part 5 of this chapter.
 - 3.1.2 *For EVMs annotated as FCC – FEDERAL COMMUNICATIONS COMMISSION Part 15 Compliant:*

CAUTION

This device complies with part 15 of the FCC Rules. Operation is subject to the following two conditions: (1) This device may not cause harmful interference, and (2) this device must accept any interference received, including interference that may cause undesired operation.

Changes or modifications not expressly approved by the party responsible for compliance could void the user's authority to operate the equipment.

FCC Interference Statement for Class A EVM devices

NOTE: This equipment has been tested and found to comply with the limits for a Class A digital device, pursuant to part 15 of the FCC Rules. These limits are designed to provide reasonable protection against harmful interference when the equipment is operated in a commercial environment. This equipment generates, uses, and can radiate radio frequency energy and, if not installed and used in accordance with the instruction manual, may cause harmful interference to radio communications. Operation of this equipment in a residential area is likely to cause harmful interference in which case the user will be required to correct the interference at his own expense.

FCC Interference Statement for Class B EVM devices

NOTE: This equipment has been tested and found to comply with the limits for a Class B digital device, pursuant to part 15 of the FCC Rules. These limits are designed to provide reasonable protection against harmful interference in a residential installation. This equipment generates, uses and can radiate radio frequency energy and, if not installed and used in accordance with the instructions, may cause harmful interference to radio communications. However, there is no guarantee that interference will not occur in a particular installation. If this equipment does cause harmful interference to radio or television reception, which can be determined by turning the equipment off and on, the user is encouraged to try to correct the interference by one or more of the following measures:

- Reorient or relocate the receiving antenna.
- Increase the separation between the equipment and receiver.
- Connect the equipment into an outlet on a circuit different from that to which the receiver is connected.
- Consult the dealer or an experienced radio/TV technician for help.

3.2 Canada

3.2.1 For EVMs issued with an Industry Canada Certificate of Conformance to RSS-210 or RSS-247

Concerning EVMs Including Radio Transmitters:

This device complies with Industry Canada license-exempt RSSs. Operation is subject to the following two conditions:

(1) this device may not cause interference, and (2) this device must accept any interference, including interference that may cause undesired operation of the device.

Concernant les EVMs avec appareils radio:

Le présent appareil est conforme aux CNR d'Industrie Canada applicables aux appareils radio exempts de licence. L'exploitation est autorisée aux deux conditions suivantes: (1) l'appareil ne doit pas produire de brouillage, et (2) l'utilisateur de l'appareil doit accepter tout brouillage radioélectrique subi, même si le brouillage est susceptible d'en compromettre le fonctionnement.

Concerning EVMs Including Detachable Antennas:

Under Industry Canada regulations, this radio transmitter may only operate using an antenna of a type and maximum (or lesser) gain approved for the transmitter by Industry Canada. To reduce potential radio interference to other users, the antenna type and its gain should be so chosen that the equivalent isotropically radiated power (e.i.r.p.) is not more than that necessary for successful communication. This radio transmitter has been approved by Industry Canada to operate with the antenna types listed in the user guide with the maximum permissible gain and required antenna impedance for each antenna type indicated. Antenna types not included in this list, having a gain greater than the maximum gain indicated for that type, are strictly prohibited for use with this device.

Concernant les EVMs avec antennes détachables

Conformément à la réglementation d'Industrie Canada, le présent émetteur radio peut fonctionner avec une antenne d'un type et d'un gain maximal (ou inférieur) approuvé pour l'émetteur par Industrie Canada. Dans le but de réduire les risques de brouillage radioélectrique à l'intention des autres utilisateurs, il faut choisir le type d'antenne et son gain de sorte que la puissance isotrope rayonnée équivalente (p.i.r.e.) ne dépasse pas l'intensité nécessaire à l'établissement d'une communication satisfaisante. Le présent émetteur radio a été approuvé par Industrie Canada pour fonctionner avec les types d'antenne énumérés dans le manuel d'usage et ayant un gain admissible maximal et l'impédance requise pour chaque type d'antenne. Les types d'antenne non inclus dans cette liste, ou dont le gain est supérieur au gain maximal indiqué, sont strictement interdits pour l'exploitation de l'émetteur.

3.3 Japan

3.3.1 *Notice for EVMs delivered in Japan:* Please see http://www.tij.co.jp/lstds/ti_ja/general/eStore/notice_01.page 日本国内に輸入される評価用キット、ボードについては、次のところをご覧ください。
http://www.tij.co.jp/lstds/ti_ja/general/eStore/notice_01.page

3.3.2 *Notice for Users of EVMs Considered "Radio Frequency Products" in Japan:* EVMs entering Japan may not be certified by TI as conforming to Technical Regulations of Radio Law of Japan.

If User uses EVMs in Japan, not certified to Technical Regulations of Radio Law of Japan, User is required to follow the instructions set forth by Radio Law of Japan, which includes, but is not limited to, the instructions below with respect to EVMs (which for the avoidance of doubt are stated strictly for convenience and should be verified by User):

1. Use EVMs in a shielded room or any other test facility as defined in the notification #173 issued by Ministry of Internal Affairs and Communications on March 28, 2006, based on Sub-section 1.1 of Article 6 of the Ministry's Rule for Enforcement of Radio Law of Japan,
2. Use EVMs only after User obtains the license of Test Radio Station as provided in Radio Law of Japan with respect to EVMs, or
3. Use of EVMs only after User obtains the Technical Regulations Conformity Certification as provided in Radio Law of Japan with respect to EVMs. Also, do not transfer EVMs, unless User gives the same notice above to the transferee. Please note that if User does not follow the instructions above, User will be subject to penalties of Radio Law of Japan.

【無線電波を送信する製品の開発キットをお使いになる際の注意事項】 開発キットの中には技術基準適合証明を受けていないものがあります。技術適合証明を受けていないものご使用に際しては、電波法遵守のため、以下のいずれかの措置を取っていただく必要がありますのでご注意ください。

1. 電波法施行規則第6条第1項第1号に基づく平成18年3月28日総務省告示第173号で定められた電波暗室等の試験設備でご使用いただく。
2. 実験局の免許を取得後ご使用いただく。
3. 技術基準適合証明を取得後ご使用いただく。

なお、本製品は、上記の「ご使用にあたっての注意」を譲渡先、移転先に通知しない限り、譲渡、移転できないものとします。

上記を遵守頂けない場合は、電波法の罰則が適用される可能性があることをご留意ください。日本テキサス・インスツルメンツ株式会社

東京都新宿区西新宿 6 丁目 2 4 番 1 号
西新宿三井ビル

3.3.3 *Notice for EVMs for Power Line Communication:* Please see http://www.tij.co.jp/llds/ti_ja/general/eStore/notice_02.page
電力線搬送波通信についての開発キットをお使いになる際の注意事項については、次のところをご覧ください。 http://www.tij.co.jp/llds/ti_ja/general/eStore/notice_02.page

3.4 *European Union*

3.4.1 *For EVMs subject to EU Directive 2014/30/EU (Electromagnetic Compatibility Directive):*

This is a class A product intended for use in environments other than domestic environments that are connected to a low-voltage power-supply network that supplies buildings used for domestic purposes. In a domestic environment this product may cause radio interference in which case the user may be required to take adequate measures.

4 *EVM Use Restrictions and Warnings:*

4.1 EVMS ARE NOT FOR USE IN FUNCTIONAL SAFETY AND/OR SAFETY CRITICAL EVALUATIONS, INCLUDING BUT NOT LIMITED TO EVALUATIONS OF LIFE SUPPORT APPLICATIONS.

4.2 User must read and apply the user guide and other available documentation provided by TI regarding the EVM prior to handling or using the EVM, including without limitation any warning or restriction notices. The notices contain important safety information related to, for example, temperatures and voltages.

4.3 *Safety-Related Warnings and Restrictions:*

4.3.1 User shall operate the EVM within TI's recommended specifications and environmental considerations stated in the user guide, other available documentation provided by TI, and any other applicable requirements and employ reasonable and customary safeguards. Exceeding the specified performance ratings and specifications (including but not limited to input and output voltage, current, power, and environmental ranges) for the EVM may cause personal injury or death, or property damage. If there are questions concerning performance ratings and specifications, User should contact a TI field representative prior to connecting interface electronics including input power and intended loads. Any loads applied outside of the specified output range may also result in unintended and/or inaccurate operation and/or possible permanent damage to the EVM and/or interface electronics. Please consult the EVM user guide prior to connecting any load to the EVM output. If there is uncertainty as to the load specification, please contact a TI field representative. During normal operation, even with the inputs and outputs kept within the specified allowable ranges, some circuit components may have elevated case temperatures. These components include but are not limited to linear regulators, switching transistors, pass transistors, current sense resistors, and heat sinks, which can be identified using the information in the associated documentation. When working with the EVM, please be aware that the EVM may become very warm.

4.3.2 EVMs are intended solely for use by technically qualified, professional electronics experts who are familiar with the dangers and application risks associated with handling electrical mechanical components, systems, and subsystems. User assumes all responsibility and liability for proper and safe handling and use of the EVM by User or its employees, affiliates, contractors or designees. User assumes all responsibility and liability to ensure that any interfaces (electronic and/or mechanical) between the EVM and any human body are designed with suitable isolation and means to safely limit accessible leakage currents to minimize the risk of electrical shock hazard. User assumes all responsibility and liability for any improper or unsafe handling or use of the EVM by User or its employees, affiliates, contractors or designees.

4.4 User assumes all responsibility and liability to determine whether the EVM is subject to any applicable international, federal, state, or local laws and regulations related to User's handling and use of the EVM and, if applicable, User assumes all responsibility and liability for compliance in all respects with such laws and regulations. User assumes all responsibility and liability for proper disposal and recycling of the EVM consistent with all applicable international, federal, state, and local requirements.

5. *Accuracy of Information:* To the extent TI provides information on the availability and function of EVMs, TI attempts to be as accurate as possible. However, TI does not warrant the accuracy of EVM descriptions, EVM availability or other information on its websites as accurate, complete, reliable, current, or error-free.

6. *Disclaimers:*
- 6.1 EXCEPT AS SET FORTH ABOVE, EVMS AND ANY MATERIALS PROVIDED WITH THE EVM (INCLUDING, BUT NOT LIMITED TO, REFERENCE DESIGNS AND THE DESIGN OF THE EVM ITSELF) ARE PROVIDED "AS IS" AND "WITH ALL FAULTS." TI DISCLAIMS ALL OTHER WARRANTIES, EXPRESS OR IMPLIED, REGARDING SUCH ITEMS, INCLUDING BUT NOT LIMITED TO ANY EPIDEMIC FAILURE WARRANTY OR IMPLIED WARRANTIES OF MERCHANTABILITY OR FITNESS FOR A PARTICULAR PURPOSE OR NON-INFRINGEMENT OF ANY THIRD PARTY PATENTS, COPYRIGHTS, TRADE SECRETS OR OTHER INTELLECTUAL PROPERTY RIGHTS.
- 6.2 EXCEPT FOR THE LIMITED RIGHT TO USE THE EVM SET FORTH HEREIN, NOTHING IN THESE TERMS SHALL BE CONSTRUED AS GRANTING OR CONFERRING ANY RIGHTS BY LICENSE, PATENT, OR ANY OTHER INDUSTRIAL OR INTELLECTUAL PROPERTY RIGHT OF TI, ITS SUPPLIERS/LICENSORS OR ANY OTHER THIRD PARTY, TO USE THE EVM IN ANY FINISHED END-USER OR READY-TO-USE FINAL PRODUCT, OR FOR ANY INVENTION, DISCOVERY OR IMPROVEMENT, REGARDLESS OF WHEN MADE, CONCEIVED OR ACQUIRED.
7. *USER'S INDEMNITY OBLIGATIONS AND REPRESENTATIONS.* USER WILL DEFEND, INDEMNIFY AND HOLD TI, ITS LICENSORS AND THEIR REPRESENTATIVES HARMLESS FROM AND AGAINST ANY AND ALL CLAIMS, DAMAGES, LOSSES, EXPENSES, COSTS AND LIABILITIES (COLLECTIVELY, "CLAIMS") ARISING OUT OF OR IN CONNECTION WITH ANY HANDLING OR USE OF THE EVM THAT IS NOT IN ACCORDANCE WITH THESE TERMS. THIS OBLIGATION SHALL APPLY WHETHER CLAIMS ARISE UNDER STATUTE, REGULATION, OR THE LAW OF TORT, CONTRACT OR ANY OTHER LEGAL THEORY, AND EVEN IF THE EVM FAILS TO PERFORM AS DESCRIBED OR EXPECTED.
8. *Limitations on Damages and Liability:*
- 8.1 *General Limitations.* IN NO EVENT SHALL TI BE LIABLE FOR ANY SPECIAL, COLLATERAL, INDIRECT, PUNITIVE, INCIDENTAL, CONSEQUENTIAL, OR EXEMPLARY DAMAGES IN CONNECTION WITH OR ARISING OUT OF THESE TERMS OR THE USE OF THE EVMS , REGARDLESS OF WHETHER TI HAS BEEN ADVISED OF THE POSSIBILITY OF SUCH DAMAGES. EXCLUDED DAMAGES INCLUDE, BUT ARE NOT LIMITED TO, COST OF REMOVAL OR REINSTALLATION, ANCILLARY COSTS TO THE PROCUREMENT OF SUBSTITUTE GOODS OR SERVICES, RETESTING, OUTSIDE COMPUTER TIME, LABOR COSTS, LOSS OF GOODWILL, LOSS OF PROFITS, LOSS OF SAVINGS, LOSS OF USE, LOSS OF DATA, OR BUSINESS INTERRUPTION. NO CLAIM, SUIT OR ACTION SHALL BE BROUGHT AGAINST TI MORE THAN TWELVE (12) MONTHS AFTER THE EVENT THAT GAVE RISE TO THE CAUSE OF ACTION HAS OCCURRED.
- 8.2 *Specific Limitations.* IN NO EVENT SHALL TI'S AGGREGATE LIABILITY FROM ANY USE OF AN EVM PROVIDED HEREUNDER, INCLUDING FROM ANY WARRANTY, INDEMNITY OR OTHER OBLIGATION ARISING OUT OF OR IN CONNECTION WITH THESE TERMS, , EXCEED THE TOTAL AMOUNT PAID TO TI BY USER FOR THE PARTICULAR EVM(S) AT ISSUE DURING THE PRIOR TWELVE (12) MONTHS WITH RESPECT TO WHICH LOSSES OR DAMAGES ARE CLAIMED. THE EXISTENCE OF MORE THAN ONE CLAIM SHALL NOT ENLARGE OR EXTEND THIS LIMIT.
9. *Return Policy.* Except as otherwise provided, TI does not offer any refunds, returns, or exchanges. Furthermore, no return of EVM(s) will be accepted if the package has been opened and no return of the EVM(s) will be accepted if they are damaged or otherwise not in a resalable condition. If User feels it has been incorrectly charged for the EVM(s) it ordered or that delivery violates the applicable order, User should contact TI. All refunds will be made in full within thirty (30) working days from the return of the components(s), excluding any postage or packaging costs.
10. *Governing Law:* These terms and conditions shall be governed by and interpreted in accordance with the laws of the State of Texas, without reference to conflict-of-laws principles. User agrees that non-exclusive jurisdiction for any dispute arising out of or relating to these terms and conditions lies within courts located in the State of Texas and consents to venue in Dallas County, Texas. Notwithstanding the foregoing, any judgment may be enforced in any United States or foreign court, and TI may seek injunctive relief in any United States or foreign court.

IMPORTANT NOTICE FOR TI DESIGN INFORMATION AND RESOURCES

Texas Instruments Incorporated ("TI") technical, application or other design advice, services or information, including, but not limited to, reference designs and materials relating to evaluation modules, (collectively, "TI Resources") are intended to assist designers who are developing applications that incorporate TI products; by downloading, accessing or using any particular TI Resource in any way, you (individually or, if you are acting on behalf of a company, your company) agree to use it solely for this purpose and subject to the terms of this Notice.

TI's provision of TI Resources does not expand or otherwise alter TI's applicable published warranties or warranty disclaimers for TI products, and no additional obligations or liabilities arise from TI providing such TI Resources. TI reserves the right to make corrections, enhancements, improvements and other changes to its TI Resources.

You understand and agree that you remain responsible for using your independent analysis, evaluation and judgment in designing your applications and that you have full and exclusive responsibility to assure the safety of your applications and compliance of your applications (and of all TI products used in or for your applications) with all applicable regulations, laws and other applicable requirements. You represent that, with respect to your applications, you have all the necessary expertise to create and implement safeguards that (1) anticipate dangerous consequences of failures, (2) monitor failures and their consequences, and (3) lessen the likelihood of failures that might cause harm and take appropriate actions. You agree that prior to using or distributing any applications that include TI products, you will thoroughly test such applications and the functionality of such TI products as used in such applications. TI has not conducted any testing other than that specifically described in the published documentation for a particular TI Resource.

You are authorized to use, copy and modify any individual TI Resource only in connection with the development of applications that include the TI product(s) identified in such TI Resource. NO OTHER LICENSE, EXPRESS OR IMPLIED, BY ESTOPPEL OR OTHERWISE TO ANY OTHER TI INTELLECTUAL PROPERTY RIGHT, AND NO LICENSE TO ANY TECHNOLOGY OR INTELLECTUAL PROPERTY RIGHT OF TI OR ANY THIRD PARTY IS GRANTED HEREIN, including but not limited to any patent right, copyright, mask work right, or other intellectual property right relating to any combination, machine, or process in which TI products or services are used. Information regarding or referencing third-party products or services does not constitute a license to use such products or services, or a warranty or endorsement thereof. Use of TI Resources may require a license from a third party under the patents or other intellectual property of the third party, or a license from TI under the patents or other intellectual property of TI.

TI RESOURCES ARE PROVIDED "AS IS" AND WITH ALL FAULTS. TI DISCLAIMS ALL OTHER WARRANTIES OR REPRESENTATIONS, EXPRESS OR IMPLIED, REGARDING TI RESOURCES OR USE THEREOF, INCLUDING BUT NOT LIMITED TO ACCURACY OR COMPLETENESS, TITLE, ANY EPIDEMIC FAILURE WARRANTY AND ANY IMPLIED WARRANTIES OF MERCHANTABILITY, FITNESS FOR A PARTICULAR PURPOSE, AND NON-INFRINGEMENT OF ANY THIRD PARTY INTELLECTUAL PROPERTY RIGHTS.

TI SHALL NOT BE LIABLE FOR AND SHALL NOT DEFEND OR INDEMNIFY YOU AGAINST ANY CLAIM, INCLUDING BUT NOT LIMITED TO ANY INFRINGEMENT CLAIM THAT RELATES TO OR IS BASED ON ANY COMBINATION OF PRODUCTS EVEN IF DESCRIBED IN TI RESOURCES OR OTHERWISE. IN NO EVENT SHALL TI BE LIABLE FOR ANY ACTUAL, DIRECT, SPECIAL, COLLATERAL, INDIRECT, PUNITIVE, INCIDENTAL, CONSEQUENTIAL OR EXEMPLARY DAMAGES IN CONNECTION WITH OR ARISING OUT OF TI RESOURCES OR USE THEREOF, AND REGARDLESS OF WHETHER TI HAS BEEN ADVISED OF THE POSSIBILITY OF SUCH DAMAGES.

You agree to fully indemnify TI and its representatives against any damages, costs, losses, and/or liabilities arising out of your non-compliance with the terms and provisions of this Notice.

This Notice applies to TI Resources. Additional terms apply to the use and purchase of certain types of materials, TI products and services. These include; without limitation, TI's standard terms for semiconductor products (<http://www.ti.com/sc/docs/stdterms.htm>), [evaluation modules](#), and [samples](http://www.ti.com/sc/docs/sampterm.htm) (<http://www.ti.com/sc/docs/sampterm.htm>).

Mailing Address: Texas Instruments, Post Office Box 655303, Dallas, Texas 75265
Copyright © 2017, Texas Instruments Incorporated