

THIS IS A C.A.D. GENERATED DRAWING
DO NOT MAKE MANUAL REVISIONS TO MASTER.

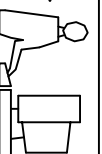

ISSUE NUMBER
ORIGINAL

①

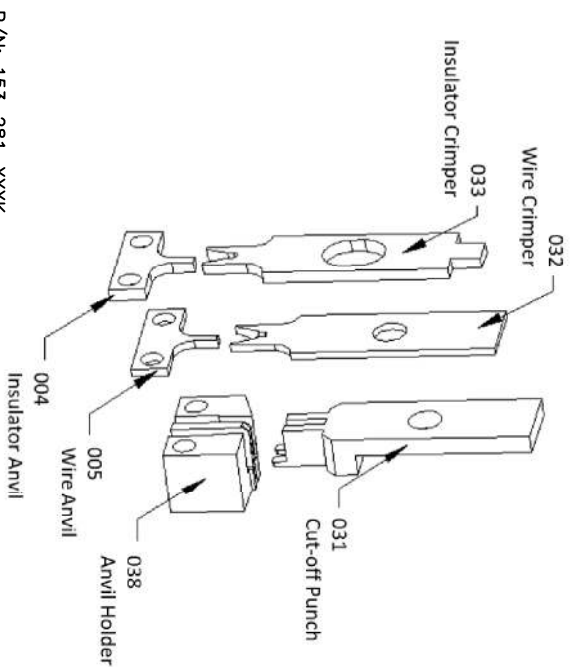
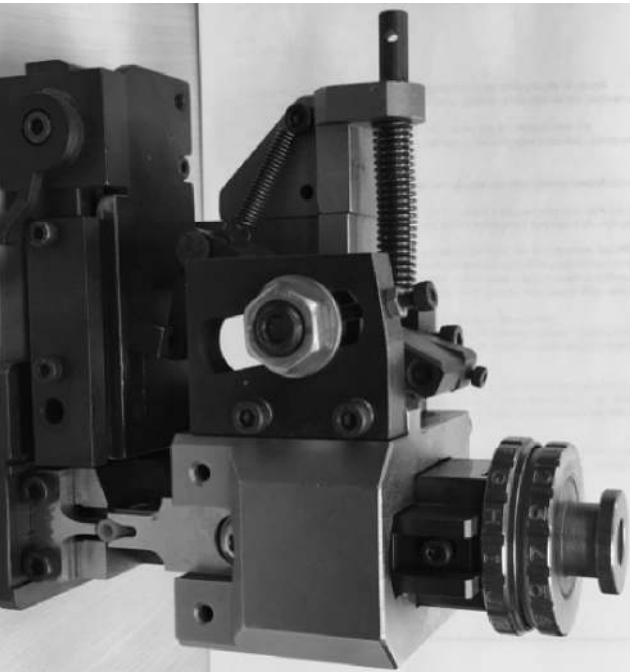

P/N: 153-281-XXXX

PRESS TYPE	K PRESS
STROKE LENGTH	30.00 MM
SHUT HEIGHT	119.55 MM
AWG	22-26

REPLACEMENT PUNCH & DIE PARTS					
INSULATOR ANVIL	WIRE ANVIL	WIRE CRIMPER	INSULATOR CRIMPER	CUT OFF PUNCH	ANVIL HOLDER
153-281-004K	153-281-005K	153-281-032K	153-281-033K	153-281-031K	153-281-038K

NOTES:

- 1- THIS APPLICATOR IS DESIGNED TO BE USED ON A K CRIMPING MACHINE.
- 2- THIS APPLICATOR IS DESIGNED FOR CRIMPING EDAC CONTACT P/N 153-290-291.
- 3- FOR THE DEFINITION OF STROKE LENGTH AND SHUT HEIGHT, APPLICATOR SETUP AND OPERATING INSTRUCTION, PLEASE REFER TO DOCUMENT "APPLICATOR INSTRUCTION MANUAL K PRESS".

K PRESS APPLICATOR FOR 153-290-291

EDAC INC
TORONTO, ONTARIO
CANADA

THESE DRAWINGS AND SPECIFICATIONS
ARE THE PROPERTY OF EDAC INC. AND
SHALL NOT BE REPRODUCED, OR COPIED
OR USED AS THE BASIS FOR THE
MANUFACTURE OR SALE OF APPARATUS
WITHOUT WRITTEN PERMISSION.

ACAD REFERENCE NO.	153-280-750K
DRAWN:	K.L.
CHECKED:	R.S.M.
SCALE:	N.T.S.
DRAWING NUMBER	153-280-750K
SHEET	1 OF 1
ISSUE	1