

13	12	11	10	9	8	7	6	5	4	3	2	1
PART NUMBER	ENGINEERING NUMBER	FINISH LENGTH										
1300620221	114130A56M020	6.56' +3.50"-0 [2M +88.9 -0]										

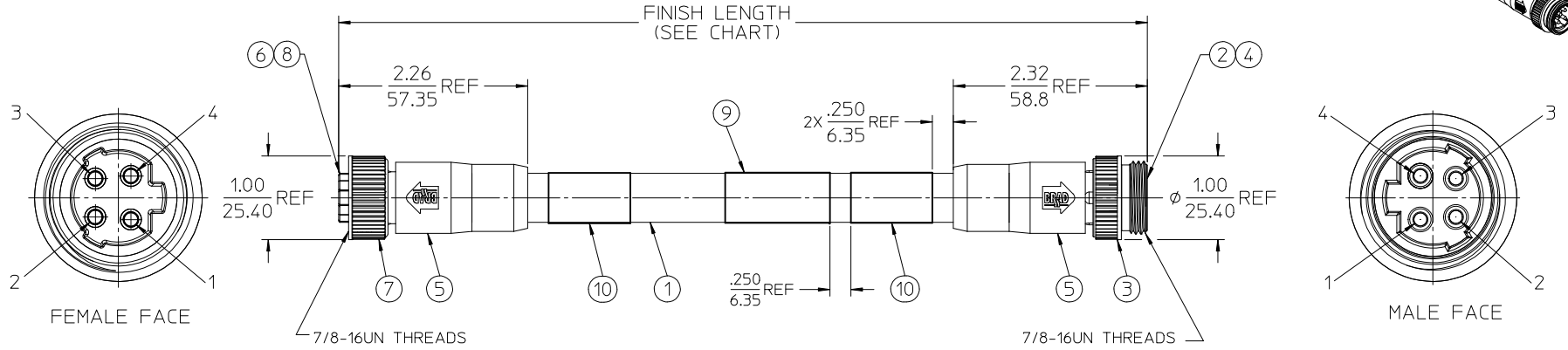
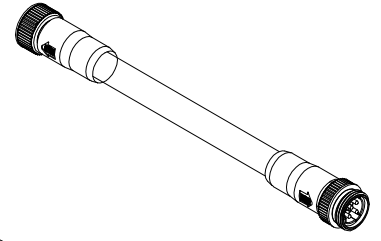

NOTES:

- 1) MATERIAL: SEE TABLE
- 2) FINISHES: SEE TABLE
- 3) WRAP LABEL IS MARKED WITH P/N, DATE CODE VOLTAGE & AMPERAGE
- 4) MATES WITH: MINI CHANGE ALT-KEY, 4 POLE RECEPTACLE
- 5) ELECTRICAL DATA:  
14AWG UL TYPE: TC-ER/ST00W STRANDED CABLE  
POLES: 4  
MAX VOLTAGE: 600V  
MAX CURRENT: 15A  
PROTECTION IP67  
TEMPERATURE RANGE: -20°C TO 90°C
- 6) PACKAGING:  
CABLE ASSEMBLIES ARE BAGGED SEPERATLY IN POLY BAGS WITH BAR CODE LABEL ATTACHED TO OUTSIDE OF BAG.
- 7) ASSEMBLY IS RoHS COMPLIANT
- 8) AGENCY CERTIFICATIONS:  
UL 2237 LISTED, E258922

S1	BLACK	P1
1	WHITE	1
2	RED	2
3	GREEN/YELLOW OR GREEN	3
4		4

WIRING DIAGRAM

CUSTOMER PRODUCTION APPROVAL  
 APPROVED BY: \_\_\_\_\_  
 DATE: \_\_\_\_\_  
 MUST BE SIGNED AND RETURNED BEFORE PRODUCTION WILL BEGIN.

10	2	WARNING LABEL	MYLAR	N/A
9	1	LABEL	MYLAR	BLACK/YELLOW
8	1	FEMALE INSERT	PVC	BLACK
7	1	FEMALE COUPLING NUT	ZINC ALLOY	BLACK
6	4	SOCKET CONTACT	CU ALLOY	GOLD PLATE
5	2	OVERMOLD	PVC	BLACK
4	1	MALE INSERT	PVC	BLACK
3	1	MALE COUPLING NUT	ZINC ALLOY	BLACK
2	4	PIN CONTACT	CU ALLOY	GOLD PLATE
1	SEE TABLE	CABLE 14AWG-TC-ER/ST00W	PVC	BLACK
ITEM	QTY	DESCRIPTION	MATERIAL	FINISH

RELEASED	EC NO: MNA2011-0552	2012/01/16
DRW: BRUPERT	CHKD: JFMURPHY	APPR: JFMURPHY
REV	DESCRIPTION	DATE
A		2012/03/20

QUALITY SYMBOLS	GENERAL TOLERANCES (UNLESS SPECIFIED)
▽=0	
▽=0	
	DRAFT WHERE APPLICABLE MUST REMAIN WITHIN DIMENSIONS

DRAWN BY	DATE
BRUPERT	2011/07/11
CHECKED BY	DATE
JFMURPHY	2012/03/20
APPROVED BY	DATE
JFMURPHY	2012/03/20
MATERIAL NO.	DOCUMENT NO.
SEE CHART	SD-130062-009

SCALE	DESIGN UNITS	THIRD ANGLE PROJECTION
15:1	INCH	
TITLE		
MC 4P FEM/MALE STR/STR 4 POLE ALT KEY 14-4 TC ER BLACK JACKET		
MOLEX INCORPORATED		
SIZE	SHEET NO.	
C	1 OF 1	
THIS DRAWING CONTAINS INFORMATION THAT IS PROPRIETARY TO MOLEX INCORPORATED AND SHOULD NOT BE USED WITHOUT WRITTEN PERMISSION		