

REVISIONS				
P.	LTN	DESCRIPTION	DATE	APVD
F		REVISED PER ECR-14-016951	11FEB2015	J.T W.H

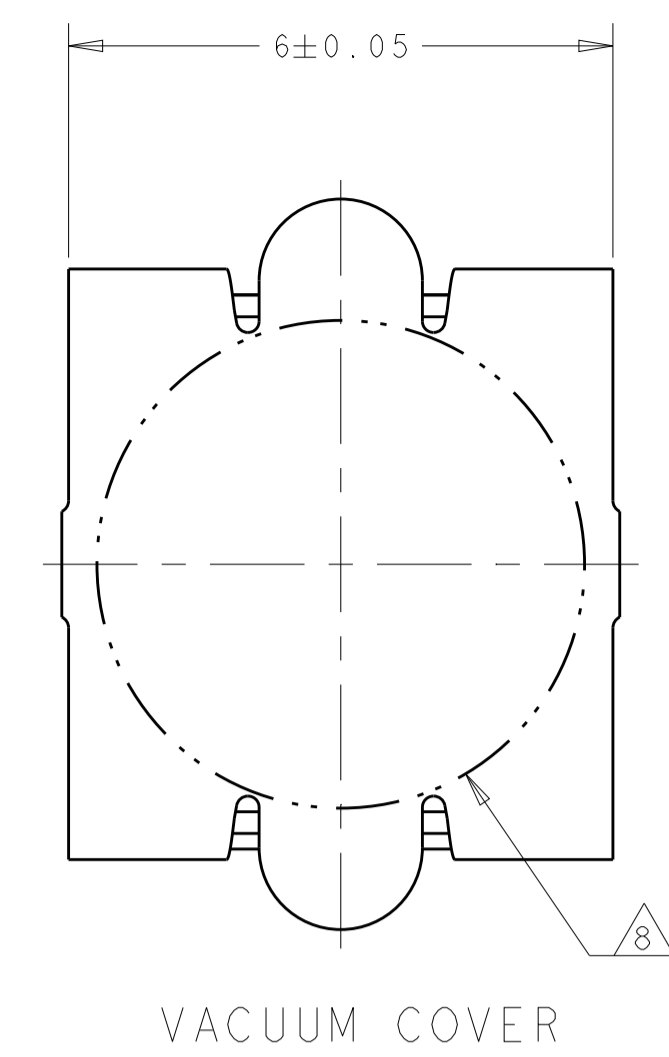

- 1 HOUSING MATERIAL: LIQUID CRYSTAL POLYMER COLOR: BLACK. CONTACT MATERIAL: PHOSPHOR BRONZE.
- 2 CONTACT FINISH: NICKEL UNDERPLATE ALL OVER, MATING SURFACES PLATED TO MEET PLI PERFORMANCE REQUIREMENTS OF INDUSTRY SPECIFICATION EIA-700AAAB, SOLDER TAILS PLATED TIN-LEAD.
- 3 DATUM LOCATIONS AND BASIC DIMENSIONS TO BE ESTABLISHED BY THE CUSTOMER. CONSULT AMP ENGINEERING WHEN PLACING MULTIPLE CONNECTORS ON A PC BOARD.
- 4 PACKAGED IN TAPE ON REELS PER EIA-841.
- 5 1.4±0.05 DIAMETER HOLE WHEN PLACING BY HAND.
- 6 SHORTER SOLDER LANDS MAY BE USED PER EIA 700AAAB, HOWEVER 2.7 LENGTH ASSURES OPTIMUM SOLDER FILLET.
- 7 REFERRED TO AS DIM N IN EIA 700AAAB SPECIFICATION.
- 8 VACUUM COVER NOT SHOWN IN SOME VIEWS FOR CLARITY.
- 9 5.5 MIN DIAMETER TARGET AREA FOR VACUUM PIPCK-UP.
- 10 CONTACT FINISH: 0.002 MINIMUM BRIGHT TIN-LEAD (93-7) ON SOLDER AREA, 0.00127 MINIMUM GOLD ON MATING AREA, BOTH OVER 0.00127 MINIMUM NICKEL ON ENTIRE CONTACT.
- 11 SQUARE AND DIAMOND SHAPED POSTS.
- 12 ROUND SHAPED POSTS.

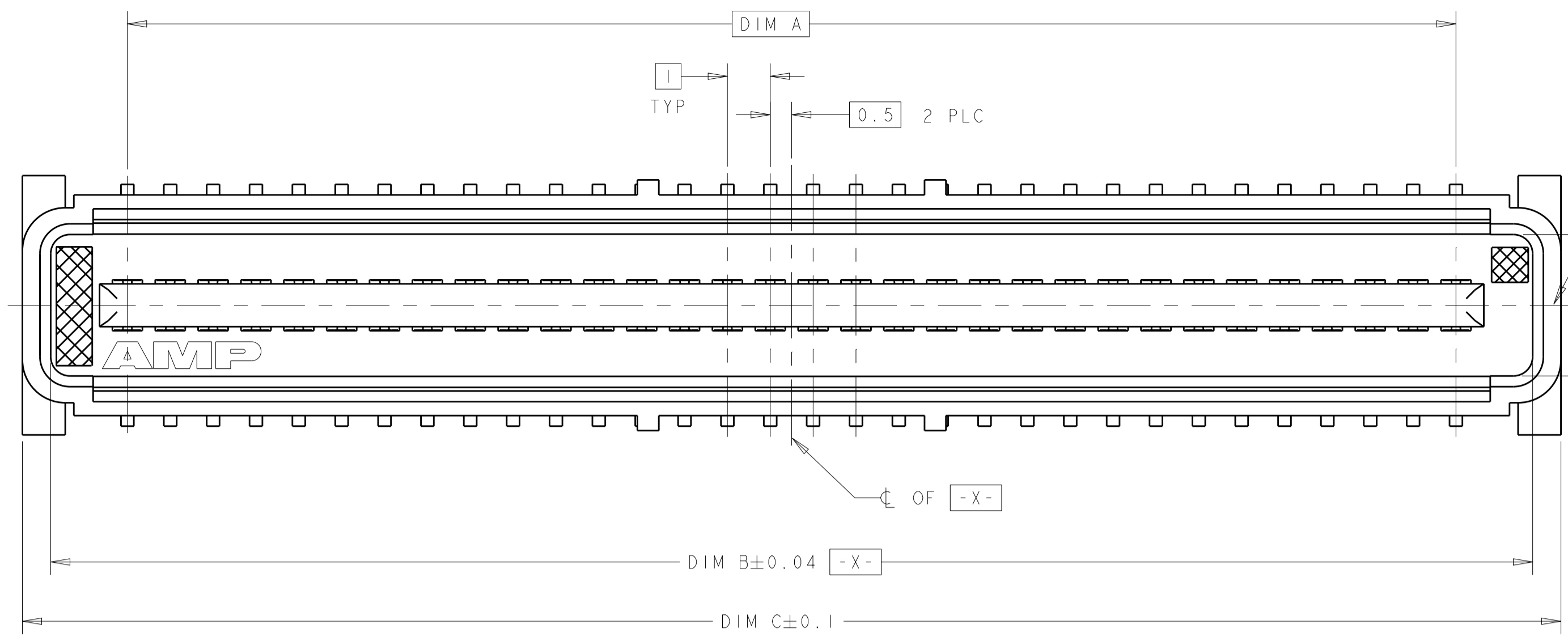
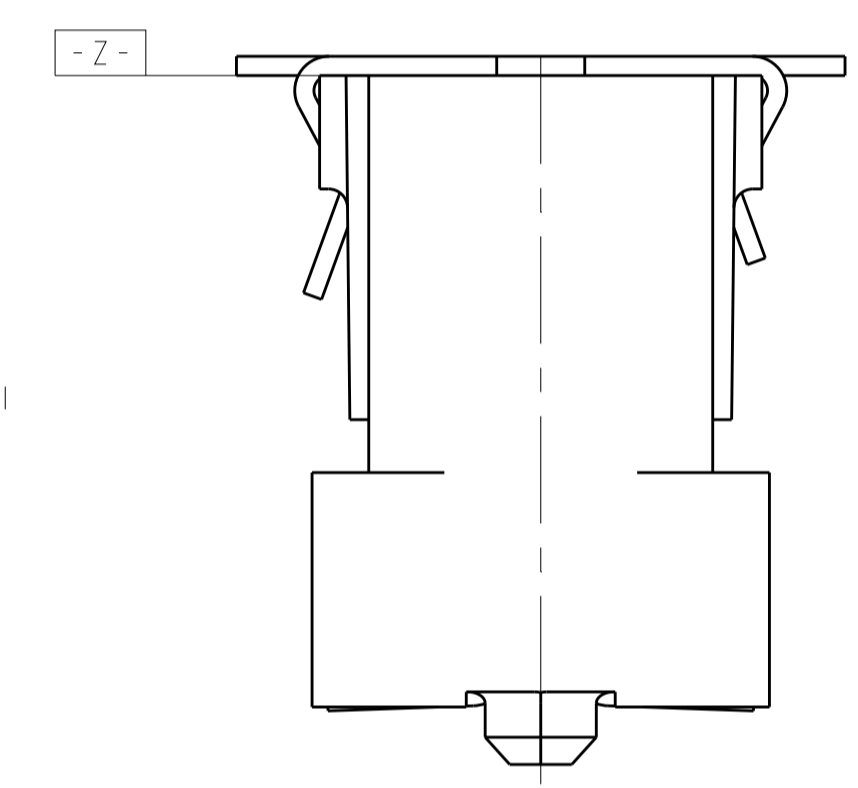
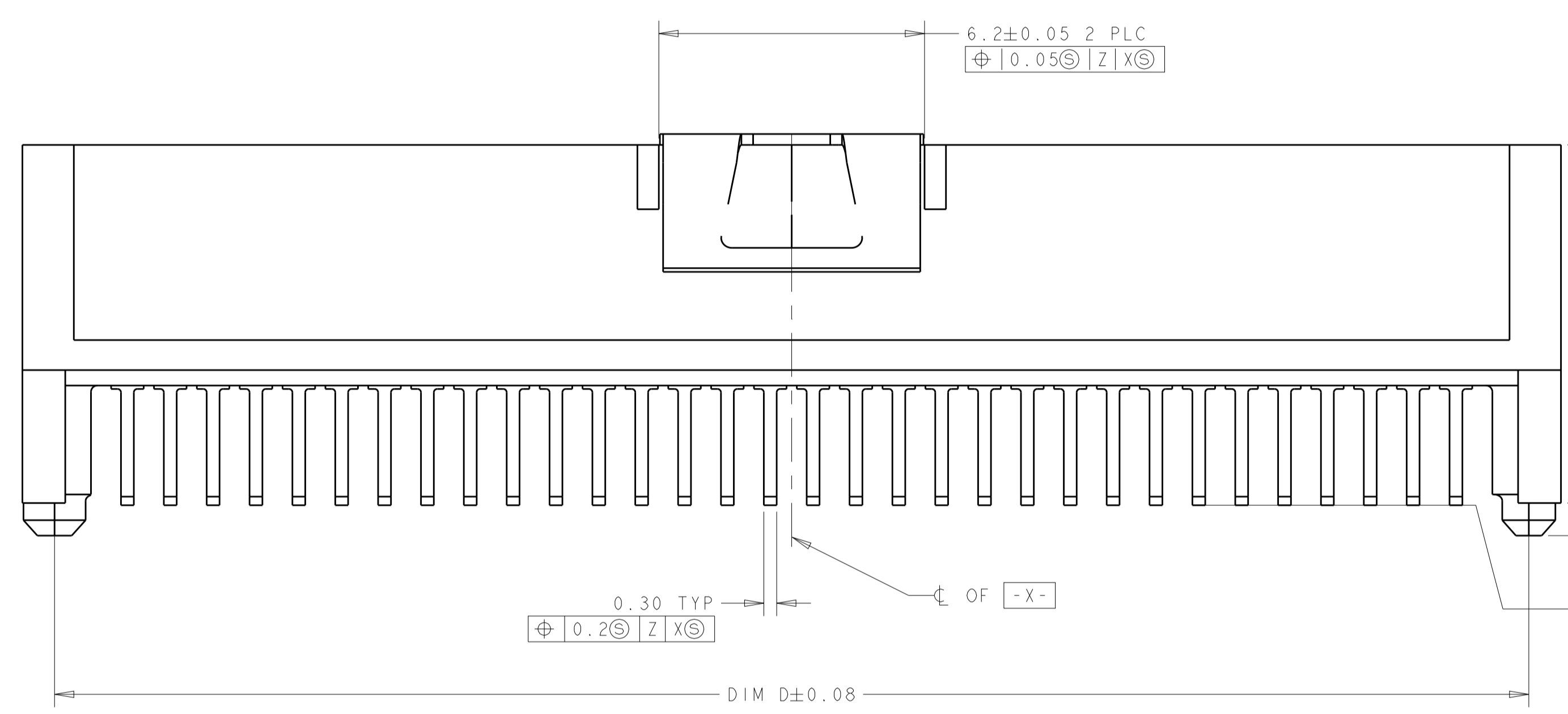

STYLE A POSTS

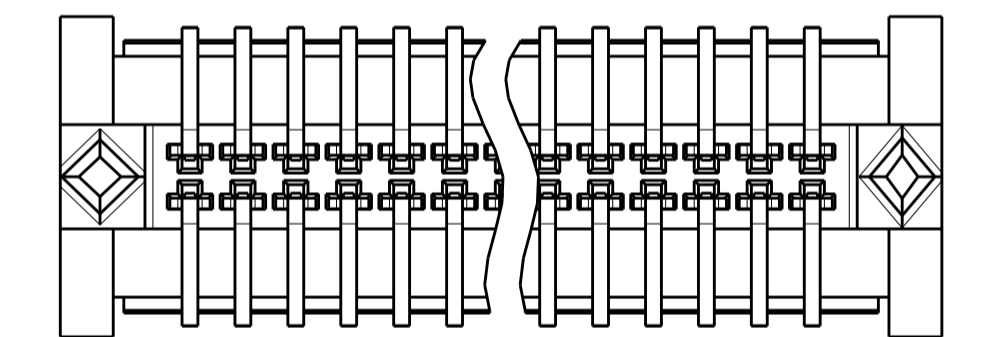

STYLE B POSTS

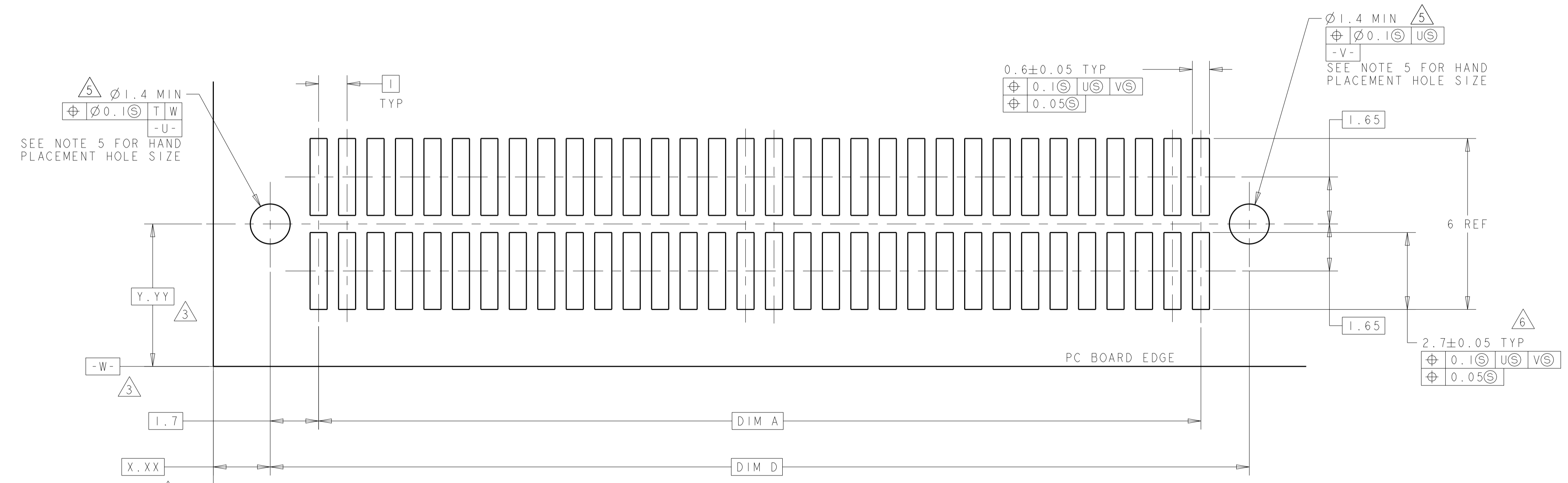
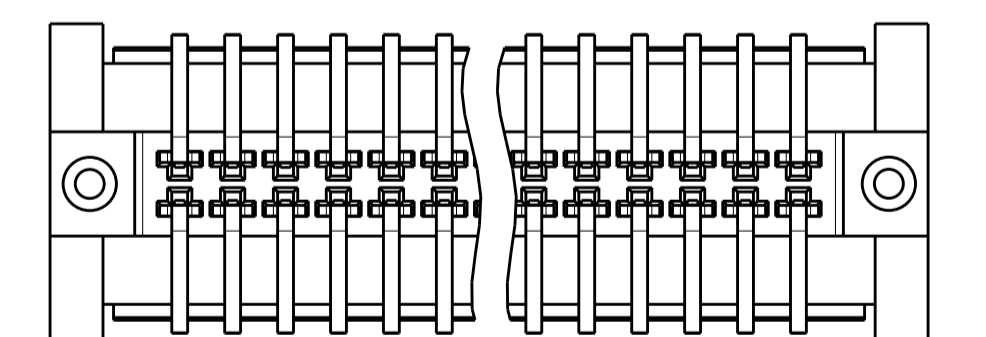

RECOMMENDED PC BOARD LAYOUT

POST STYLE	FINISH	DIM D	DIM C	DIM B	DIM A	STACK HEIGHTS	POS	AMP PART NUMBER
1	10	44.4	45.9	44.58	41	10, 12, 13, 15	84	3-146888-2
2	10	34.4	35.9	34.58	31	10, 12, 13, 15	64	3-146888-1
1	2	44.4	45.9	44.58	41	10, 12, 13, 15	84	2-146888-2
2	2	34.4	35.9	34.58	31	10, 12, 13, 15	64	2-146888-1
1	10	44.4	45.9	44.58	41	10, 12, 13, 15	84	1-146888-2
1	2	34.4	35.9	34.58	31	10, 12, 13, 15	64	1-146888-1
1	2	44.4	45.9	44.58	41	10, 12, 13, 15	84	146888-2
1	2	34.4	35.9	34.58	31	10, 12, 13, 15	64	146888-1

THIS DRAWING IS A CONTROLLED DOCUMENT. DWG: DK_SCHRUM 117SEP98. CHK: CHAD_BAKER 117SEP98. NAME: -

DIMENSIONS: mm. TOLERANCES UNLESS OTHERWISE SPECIFIED: 0 PLC ±. 2 PLC ±0.03. 3 PLC ±0.003. 4 PLC ±. ANGLES 40°±30'.

MATERIAL: SEE TABLE. FINISH: SEE TABLE.

PRODUCT SPEC: 502-1079. APPLICATION SPEC: 114-25045. WEIGHT: -. CAGE CODE: 1100779. DRAWING NO: A100779. CUSTOMER DRAWING.

TE Connectivity. PLUG ASSEMBLY, W/VACUUM COVER, 1.0mm FH(IEEE 1386) CONNECTOR. SCALE: 10:1. SHEET: 1 OF 1. REV: F.