



Ultra Low Noise, Offset Drift ± 1 g Dual Axis Accelerometer with Analog Outputs

MXA2500E

FEATURES

- Better than 1 mg resolution
- Dual axis accelerometer fabricated on a monolithic CMOS IC
- RoHS compliant
- On-chip mixed mode signal processing
- No moving parts
- 50,000 g shock survival rating
- 17 Hz bandwidth expandable to >160 Hz
- 3V to 5.25V single supply continuous operation
- Small (5mm x 5mm x 2mm) surface mount package
- Continuous self test
- Custom programmable specifications
- Independent axis programmability (special order)

APPLICATIONS

- Automotive – Vehicle Security/Active Suspension/ABS
 - Headlight Angle Control/Tilt Sensing
- Security – Gas Line/Elevator/Fatigue Sensing
- Office Equipment – Computer Peripherals/PDA's/
 - Cell Phones
- Gaming – Joystick/RF Interface/Menu Selection/Tilt Sensing
- White Goods – Spin/Vibration Control

GENERAL DESCRIPTION

The MXA2500E is an ultra low noise and low cost, dual axis accelerometer fabricated on a standard, submicron CMOS process. It is a complete sensing system with on-chip mixed mode signal processing. The MXA2500E measures acceleration with a full-scale range of ± 1 g and a sensitivity of 500mV/g @5V at 25°C. It can measure both dynamic acceleration (e.g., vibration) and static acceleration (e.g., gravity). The MXA2500E design is based on heat convection and requires no solid proof mass. This eliminates stiction and particle problems associated with competitive devices and provides shock survival of 50,000 g, leading to significantly lower failure rates and lower loss due to handling during assembly.

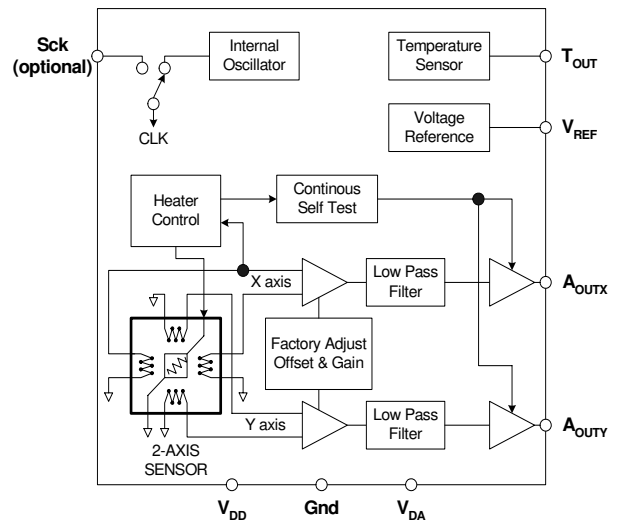

MXA2500E FUNCTIONAL BLOCK DIAGRAM

The MXA2500E provides two absolute analog outputs. The typical noise floor is $0.2 \text{ mg}/\sqrt{\text{Hz}}$ allowing signals below 1 mg to be resolved at 1 Hz bandwidth. The 3dB rolloff of the device occurs at 17 Hz but is expandable to >160 Hz (ref. Application Note AN-00MX-003). The MXA2500E is available in a LCC surface mount package (5 mm x 5 mm x 2 mm). It is hermetically sealed and is operational over a -40°C to +105°C temperature range. It also contains an on-chip temperature sensor and a bandgap voltage reference.

Due to the standard CMOS structure of the MXA2500E, additional circuitry can easily be incorporated into custom versions for high volume applications. Contact the factory for more information.

Information furnished by MEMSIC is believed to be accurate and reliable. However, no responsibility is assumed by MEMSIC for its use, nor for any infringements of patents or other rights of third parties which may result from its use. No license is granted by implication or otherwise under any patent or patent rights of MEMSIC.

©MEMSIC, Inc.
One Technology Drive Suite 325, Andover MA 01810, USA
Tel: +1 978 738 0900 Fax: +1 978 738 0196
www.memsic.com

MXA2500E SPECIFICATIONS (Measurements @ 25°C, Acceleration = 0 g unless otherwise noted; V_{DD}, V_{DA} = 5.0V unless otherwise specified)

Parameter	Conditions	MXA2500E			Units
		Min	Typ	Max	
SENSOR INPUT	Each Axis				
Measurement Range ¹		±1.0			g
Nonlinearity	Best fit straight line		0.5	1.0	% of FS
Alignment Error ²			±1.0		degree
Transverse Sensitivity ³			±2.0		%
SENSITIVITY	Each Axis				
Sensitivity, Analog Outputs at pins A _{OUTX} and A _{OUTY} ⁶		475	500	525	mV/g
Change over Temperature (uncompensated) ⁴	Δ from 25°C, at -40°C			+120	%
	Δ from 25°C, at +105°C	-55			%
Change over Temperature (compensated) ⁴	Δ from 25°C, -40°C to +105°C		<3.0		%
ZERO g BIAS LEVEL	Each Axis				
0 g Offset ⁶		-0.1	0.00	+0.1	g
0 g Voltage ⁶		1.20	1.25	1.30	V
0 g Offset over Temperature	Δ from 25°C		±0.4		mg/°C
	Δ from 25°C, based on 500mV/g		±0.2		mV/°C
NOISE PERFORMANCE					
Noise Density, rms	Without frequency compensation		0.2	0.4	mg/√Hz
FREQUENCY RESPONSE					
3dB Bandwidth - uncompensated			17		Hz
3dB Bandwidth - compensated ⁵			>160		Hz
TEMPERATURE OUTPUT					
T _{out} Voltage		1.15	1.25	1.35	V
Sensitivity		4.6	5.0	5.4	mV/°C
VOLTAGE REFERENCE OUTPUT					
V _{Ref} output	@3V-5.25V supply	2.4	2.5	2.65	V
Change over Temperature			0.1		mV/°C
Current Drive Capability	Source			100	μA
SELF TEST					
Continuous Voltage at A _{OUTX} , A _{OUTY} under Failure	@5.0V Supply, output rails to supply voltage		5.0		V
Continuous Voltage at A _{OUTX} , A _{OUTY} under Failure	@3.0V Supply, output rails to supply voltage		3.0		V
A_{OUTX} and A_{OUTY} OUTPUTS					
Normal Output Range	@5.0V Supply	0.1		4.9	V
	@3.0V Supply	0.1		2.9	V
Current	Source or sink, @ 3.0V-5.25V supply			100	μA
Turn-On Time ⁷	@5.0V Supply		160		mS
	@3.0V Supply		300		mS
POWER SUPPLY					
Operating Voltage Range		3.0		5.25	V
Supply Current	@ 5.0V	2.7	3.3	4.1	mA
Supply Current ⁶	@ 3.0V	3.2	4.0	4.8	mA
TEMPERATURE RANGE					
Operating Range		-40		+105	°C

NOTES

¹ Guaranteed by measurement of initial offset and sensitivity.

² Alignment error is specified as the angle between the true and indicated axis of sensitivity.

³ Transverse sensitivity is the algebraic sum of the alignment and the inherent sensitivity errors.

⁴ The sensitivity change over temperature for thermal accelerometers is based on variations in heat transfer that are governed by the laws of physics and it is highly consistent from device to device. Please refer to the section in this data sheet titled "Compensation for the Change of Sensitivity over Temperature" for more information.

⁵ External circuitry is required to extend the 3dB bandwidth. (ref. Application Note: AN-00MX-003).

⁶ The device operates over a 3.0V to 5.25V supply range. Please note that sensitivity and zero g bias level will be slightly different at 3.0V operation. For devices to be operated at 3.0V in production, they can be trimmed at the factory specifically for this lower supply voltage operation, in which case the sensitivity and zero g bias level specifications on this page will be met. Please contact the factory for specially trimmed devices for low supply voltage operation.

⁷ Output settled to within ±17mg.

ABSOLUTE MAXIMUM RATINGS*

Supply Voltage (V_{DD} , V_{DA})-0.5 to +7.0V
 Storage Temperature-65°C to +150°C
 Acceleration50,000 g

*Stresses above those listed under Absolute Maximum Ratings may cause permanent damage to the device. This is a stress rating only; the functional operation of the device at these or any other conditions above those indicated in the operational sections of this specification is not implied. Exposure to absolute maximum rating conditions for extended periods may affect device reliability.

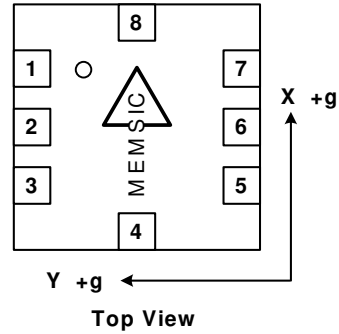

Package Characteristics

Package	θ_{JA}	θ_{JC}	Device Weight
LCC-8	110°C/W	22°C/W	< 1 gram

Pin Description: LCC-8 Package

Pin	Name	Description	I/O
1	T_{OUT}	Temperature (Analog Voltage)	O
2	A_{OUTY}	Y-Axis Acceleration Signal	O
3	Gnd	Ground	I
4	V_{DA}	Analog Supply Voltage	I
5	A_{OUTX}	X-Axis Acceleration Signal	O
6	V_{ref}	2.5V Reference Output	O
7	Sck	Optional External Clock	I
8	V_{DD}	Digital Supply Voltage	I



Note: The MEMSIC logo's arrow indicates the +X sensing direction of the device. The +Y sensing direction is rotated 90° away from the +X direction following the right-hand rule. Small circle indicates pin one (1).

Ordering Guide

Model	Package Style
MXA2500EL	LCC8 RoHS compliant
MXA2500EF	LCC8, Pb-free RoHS compliant

*LCC parts are shipped in tape and reel packaging.

Caution

ESD (electrostatic discharge) sensitive device.

THEORY OF OPERATION

The MEMSIC device is a complete dual-axis acceleration measurement system fabricated on a monolithic CMOS IC process. The device operation is based on heat transfer by natural convection and operates like other accelerometers having a proof mass except it is a gas in the MEMSIC sensor.

A single heat source, centered in the silicon chip is suspended across a cavity. Equally spaced aluminum/polysilicon thermopiles (groups of thermocouples) are located equidistantly on all four sides of the heat source (dual axis). Under zero acceleration, a temperature gradient is symmetrical about the heat source, so that the temperature is the same at all four thermopiles, causing them to output the same voltage.

Acceleration in any direction will disturb the temperature profile, due to free convection heat transfer, causing it to be asymmetrical. The temperature, and hence voltage output of the four thermopiles will then be different. The differential voltage at the thermopile outputs is directly proportional to the acceleration. There are two identical acceleration signal paths on the accelerometer, one to measure acceleration in the x-axis and one to measure acceleration in the y-axis. Please visit the MEMSIC website at www.memsic.com for a picture/graphic description of the free convection heat transfer principle.

PIN DESCRIPTIONS

V_{DD} – This is the supply input for the digital circuits and the sensor heater in the accelerometer. The DC voltage should be between 3.0 volts and 5.25 volts. Refer to the section on PCB layout and fabrication suggestions for guidance on external parts and connections recommended.

V_{DA} – This is the power supply input for the analog amplifiers in the accelerometer. Refer to the section on PCB layout and fabrication suggestions for guidance on external parts and connections recommended.

Gnd – This is the ground pin for the accelerometer.

A_{OUTX} – This pin is the output of the x-axis acceleration sensor. The user should ensure the load impedance is sufficiently high as to not source/sink >100µA. While the sensitivity of this axis has been programmed at the factory to be the same as the sensitivity for the y-axis, the accelerometer can be programmed for non-equal sensitivities on the x- and y-axes. Contact the factory for additional information on this feature.

A_{OUTY} – This pin is the output of the y-axis acceleration sensor. The user should ensure the load impedance is sufficiently high as to not source/sink >100µA. While the sensitivity of this axis has been programmed at the factory to be the same as the sensitivity for the x-axis, the accelerometer can be programmed for non-equal

sensitivities on the x- and y-axes. Contact the factory for additional information on this feature.

T_{OUT} – This pin is the buffered output of the temperature sensor. The analog voltage at T_{OUT} is an indication of the die temperature. This voltage is useful as a differential measurement of temperature from ambient and not as an absolute measurement of temperature. After correlating the voltage at T_{OUT} to 25°C ambient, the change in this voltage due to changes in the ambient temperature can be used to compensate for the change over temperature of the accelerometer offset and sensitivity. Please refer to the section on Compensation for the Change in Sensitivity Over Temperature for more information.

Sck – The standard product is delivered with an internal clock option (800kHz). **This pin should be grounded when operating with the internal clock.** An external clock option can be special ordered from the factory allowing the user to input a clock signal between 400kHz and 1.6MHz.

V_{ref} – This pin is the output of a reference voltage. It is set at 2.50V typical and has 100µA of drive capability.

COMPENSATION FOR THE CHANGE IN SENSITIVITY OVER TEMPERATURE

All thermal accelerometers display the same sensitivity change with temperature. The sensitivity change depends on variations in heat transfer that are governed by the laws of physics. Manufacturing variations do not influence the sensitivity change, so there are no unit-to-unit differences in sensitivity change. The sensitivity change is governed by the following equation (and shown in Figure 1 in °C):

$$S_i \times T_i^{2.90} = S_f \times T_f^{2.90}$$

where S_i is the sensitivity at any initial temperature T_i, and S_f is the sensitivity at any other final temperature T_f with the temperature values in °K.

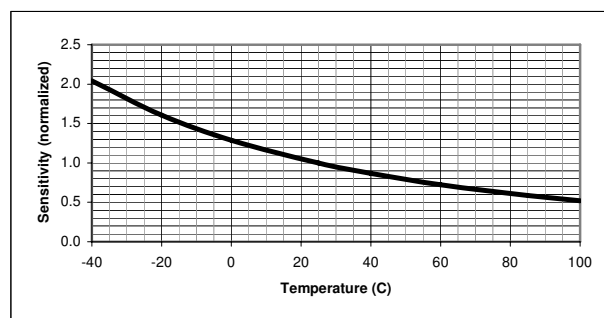

Figure 1: Thermal Accelerometer Sensitivity

In gaming applications where the game or controller is typically used in a constant temperature environment, sensitivity might not need to be compensated in hardware

or software. Any compensation for this effect could be done instinctively by the game player.

For applications where sensitivity changes of a few percent are acceptable, the above equation can be approximated with a linear function. Using a linear approximation, an external circuit that provides a gain adjustment of $-0.9\%/^{\circ}\text{C}$ would keep the sensitivity within 10% of its room temperature value over a 0°C to $+50^{\circ}\text{C}$ range.

For applications that demand high performance, a low cost micro-controller can be used to implement the above equation. A reference design using a Microchip MCU (p/n 16F873/04-SO) and MEMSIC developed firmware is available by contacting the factory. With this reference design, the sensitivity variation over the full temperature range (-40°C to $+105^{\circ}\text{C}$) can be kept below 3%. Please visit the MEMSIC web site at www.memsic.com for reference design information on circuits and programs including look up tables for easily incorporating sensitivity compensation.

DISCUSSION OF TILT APPLICATIONS AND RESOLUTION

Tilt Applications: One of the most popular applications of the MEMSIC accelerometer product line is in tilt/inclination measurement. An accelerometer uses the force of gravity as an input to determine the inclination angle of an object.

A MEMSIC accelerometer is most sensitive to changes in position, or tilt, when the accelerometer's sensitive axis is perpendicular to the force of gravity, or parallel to the Earth's surface. Similarly, when the accelerometer's axis is parallel to the force of gravity (perpendicular to the Earth's surface), it is least sensitive to changes in tilt.

Table 1 and Figure 2 help illustrate the output changes in the X- and Y-axes as the unit is tilted from $+90^{\circ}$ to 0° . Notice that when one axis has a small change in output per degree of tilt (in mg), the second axis has a large change in output per degree of tilt. The complementary nature of these two signals permits low cost accurate tilt sensing to be achieved with the MEMSIC device (reference application note AN-00MX-007).

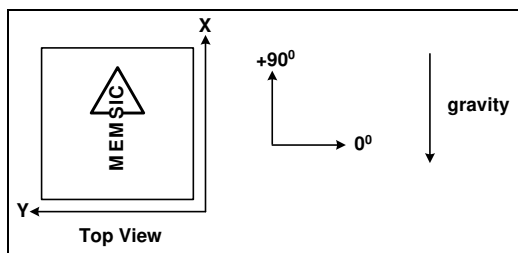

Figure 2: Accelerometer Position Relative to Gravity

X-Axis Orientation To Earth's Surface (deg.)	X-Axis		Y-Axis	
	X Output (g)	Change per deg. of tilt (mg)	Y Output (g)	Change per deg. of tilt (mg)
90	1.000	0.15	0.000	17.45
85	0.996	1.37	0.087	17.37
80	0.985	2.88	0.174	17.16
70	0.940	5.86	0.342	16.35
60	0.866	8.59	0.500	15.04
45	0.707	12.23	0.707	12.23
30	0.500	15.04	0.866	8.59
20	0.342	16.35	0.940	5.86
10	0.174	17.16	0.985	2.88
5	0.087	17.37	0.996	1.37
0	0.000	17.45	1.000	0.15

Table 1: Changes in Tilt for X- and Y-Axes

Resolution: The accelerometer resolution is limited by noise. The output noise will vary with the measurement bandwidth. With the reduction of the bandwidth, by applying an external low pass filter, the output noise drops. Reduction of bandwidth will improve the signal to noise ratio and the resolution. The output noise scales directly with the square root of the measurement bandwidth. The maximum amplitude of the noise, its peak-to-peak value, approximately defines the worst case resolution of the measurement. With a simple RC low pass filter, the rms noise is calculated as follows:

$$\text{Noise (mg rms)} = \text{Noise(mg}/\sqrt{\text{Hz}}) * \sqrt{(\text{Bandwidth(Hz)} * 1.6)}$$

The peak-to-peak noise is approximately equal to 6.6 times the rms value (for an average uncertainty of 0.1%).

EXTERNAL FILTERS

AC Coupling: For applications where only dynamic accelerations (vibration) are to be measured, it is recommended to ac couple the accelerometer output as shown in Figure 3. The advantage of ac coupling is that variations from part to part of zero g offset and zero g offset versus temperature can be eliminated. Figure 3 is a HPF (high pass filter) with a -3dB breakpoint given by the equation: $f = 1/2\pi RC$. In many applications it may be desirable to have the HPF -3dB point at a very low frequency in order to detect very low frequency accelerations. Sometimes the implementation of this HPF may result in unreasonably large capacitors, and the designer must turn to digital implementations of HPFs where very low frequency -3dB breakpoints can be achieved.

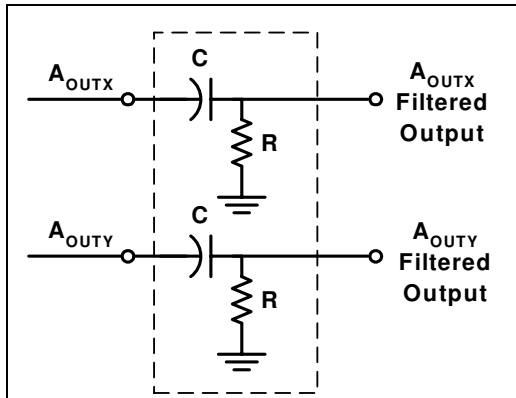

Figure 3: High Pass Filter

Low Pass Filter: An external low pass filter is useful in low frequency applications such as tilt or inclination. The low pass filter limits the noise floor and improves the resolution of the accelerometer. The low pass filter shown in Figure 4 has a -3dB breakpoint given by the equation:

$$f = \frac{1}{2\pi RC}$$

For the 200 Hz ratiometric output device filter, $C=0.1\mu\text{F}$ and $R=8\text{k}\Omega$, $\pm 5\%$, $1/8\text{W}$.

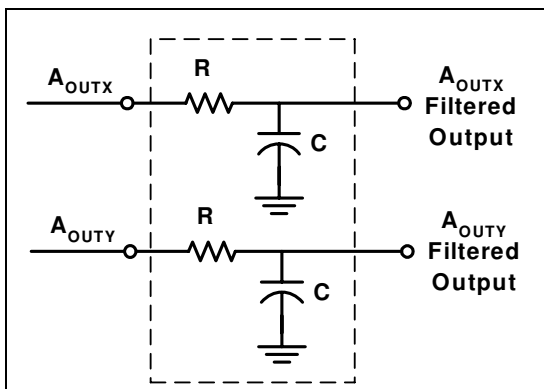

Figure 4: Low Pass Filter

COMPENSATION FOR EXTENDING THE FREQUENCY RESPONSE

The response of the thermal accelerometer is a function of the internal gas physical properties, the natural convection mechanism and the sensor electronics. Since the gas properties of MEMSIC's mass produced accelerometer are uniform, a simple circuit can be used to equally compensate all sensors. For most applications, the compensating circuit does not require adjustment for individual units.

A simple compensating network comprising two operational amplifiers and a few resistors and capacitors provides increasing gain with increasing frequency (see Figure 5). The circuit shown is for an absolute output accelerometer operating at 5 V supply. It provides a DC gain of X2, so the offset at the output is 2.5V and the sensitivity is doubled. The 14.3 K Ω and the 5.9K Ω resistors along with the non-polarized 0.82 μF capacitors tune the gain of the network to compensate for the output

attenuation at the higher frequencies. The resistors and the capacitors provide noise reduction and stability.

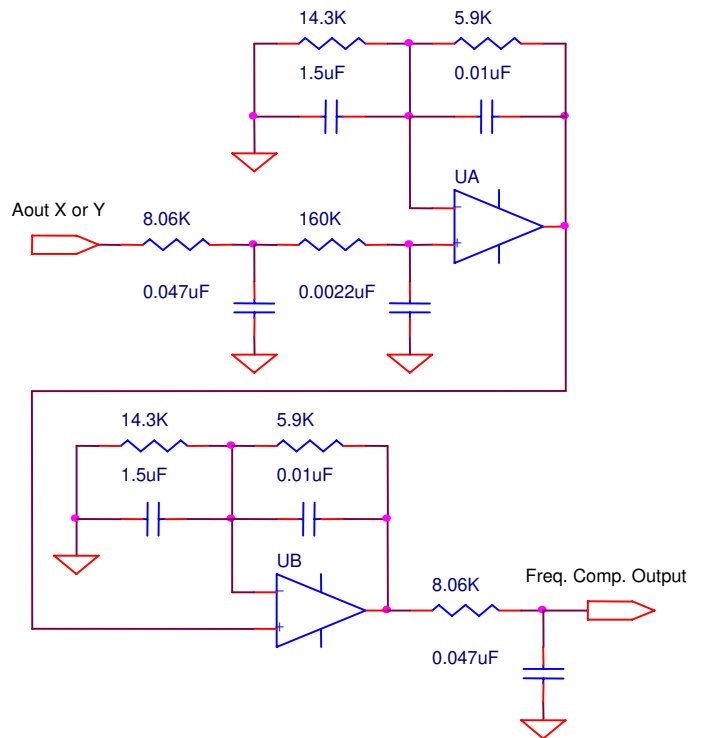

Figure 5: Frequency Response Extension Circuit

The accelerometer response (bottom trace), the network response (top trace) and the compensated response (middle trace) are shown in Figure 6. The amplitude remains above -3db beyond 100 Hz, and there is useable signal well after this frequency.

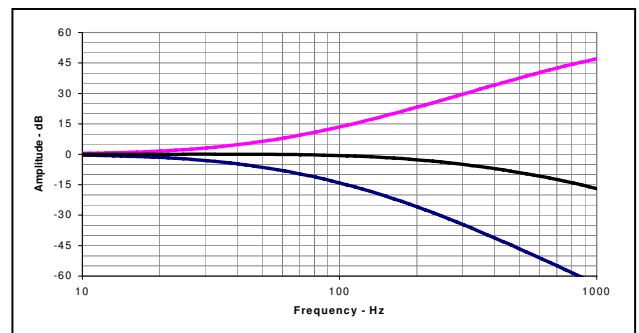

Figure 6: Amplitude Frequency Response

COMPENSATION FOR ZERO G OFFSET CHANGE OVER TEMPERATURE

In applications where a stable zero g offset is required, and where the AC coupling external filter described earlier can not be used, analog or digital temperature compensation can be applied. The compensation requires individual calibration because the magnitude of the zero g offset change over temperature is different for each unit. To

compensate the change, a calibrated temperature dependent signal equal in magnitude but with opposite polarity is added to the accelerometer output. The circuit in Figure 7 shows a circuit example applying an analog linear compensation technique. In this circuit the accelerometer temperature sensor output is added to or subtracted from the accelerometer output. The calibration sequence is: start at room temperature with the 100K pot set so that its wiper is at V_{ref} . Next, soak the accelerometer at the expected extreme temperature and observe the direction of the change. Then set the switch to the non-inverting input if the change is negative or vice versa. Finally, adjust the 100K pot while monitoring the circuit output, until the zero g offset change is removed.

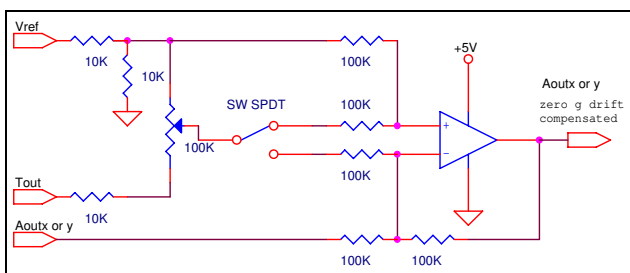

Figure 7: Zero g Offset Temperature Compensation Circuit

Various digital compensation techniques can be applied using a similar concept. Digital techniques can provide better compensation because they can compensate for non-linear zero g offset vs. temperature. A micro-controller or micro-processor would perform the compensation. The acceleration signal and the temperature signal would be digitized using an analog to digital converter. Like in the analog compensation, the first step is to test and characterize the zero g change. The purpose of the characterization is to create a look up table or to estimate a mathematical representation of the change. For example, the change could be characterized by an equation of the form:

$$\text{Change} = a * \text{Temperature}^2 + b * \text{Temperature} + c$$

where a, b, c are unique constants for each accelerometer. In normal operation the processor calculates the output:

$$\text{Compensated Output} = \text{Acceleration} - \text{Change}.$$

For a more detail discussion of temperature compensation reference MEMSIC application note #AN-00MX-002.

TEMPERATURE OUTPUT NOISE REDUCTION

It is recommended that a simple RC low pass filter is used when measuring the temperature output. Temperature output is typically a very slow changing signal, so a very

low frequency filter eliminates erroneous readings that may result from the presence of higher frequency noise. A simple filter is shown in Figure 8.

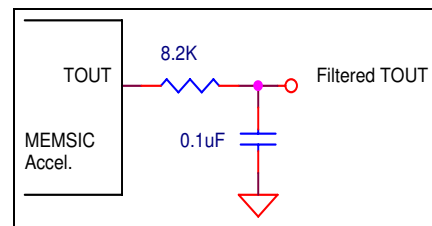

Figure 8: Temperature Output Noise Reduction

POWER SUPPLY NOISE REJECTION

Two capacitors and a resistor are recommended for best rejection of power supply noise (reference Figure 9 below). The capacitors should be located as close as possible to the device supply pins (V_{DA} , V_{DD}). The capacitor lead length should be as short as possible, and surface mount capacitors are preferred. For typical applications, capacitors C1 and C2 can be ceramic 0.1 μF , and the resistor R can be 10 Ω .

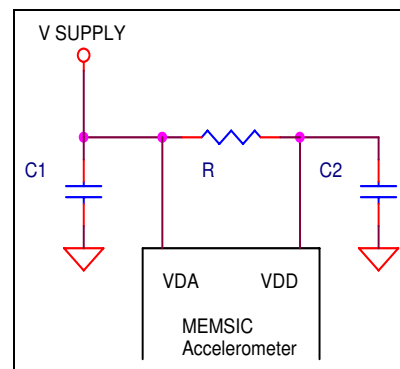

Figure 9: Power Supply Noise Rejection

PCB LAYOUT AND FABRICATION SUGGESTIONS

1. The Sck pin should be grounded to minimize noise.
2. Liberal use of ceramic bypass capacitors is recommended.
3. Robust low inductance ground wiring should be used.
4. Care should be taken to ensure there is "thermal symmetry" on the PCB immediately surrounding the MEMSIC device and that there is no significant heat source nearby.
5. A metal ground plane should be added directly beneath the MEMSIC device. The size of the ground plane should be similar to the MEMSIC device's footprint and be as thick as possible.
6. Vias can be added symmetrically around the ground plane. Vias increase thermal isolation of the device from the rest of the PCB.

PACKAGE DRAWING

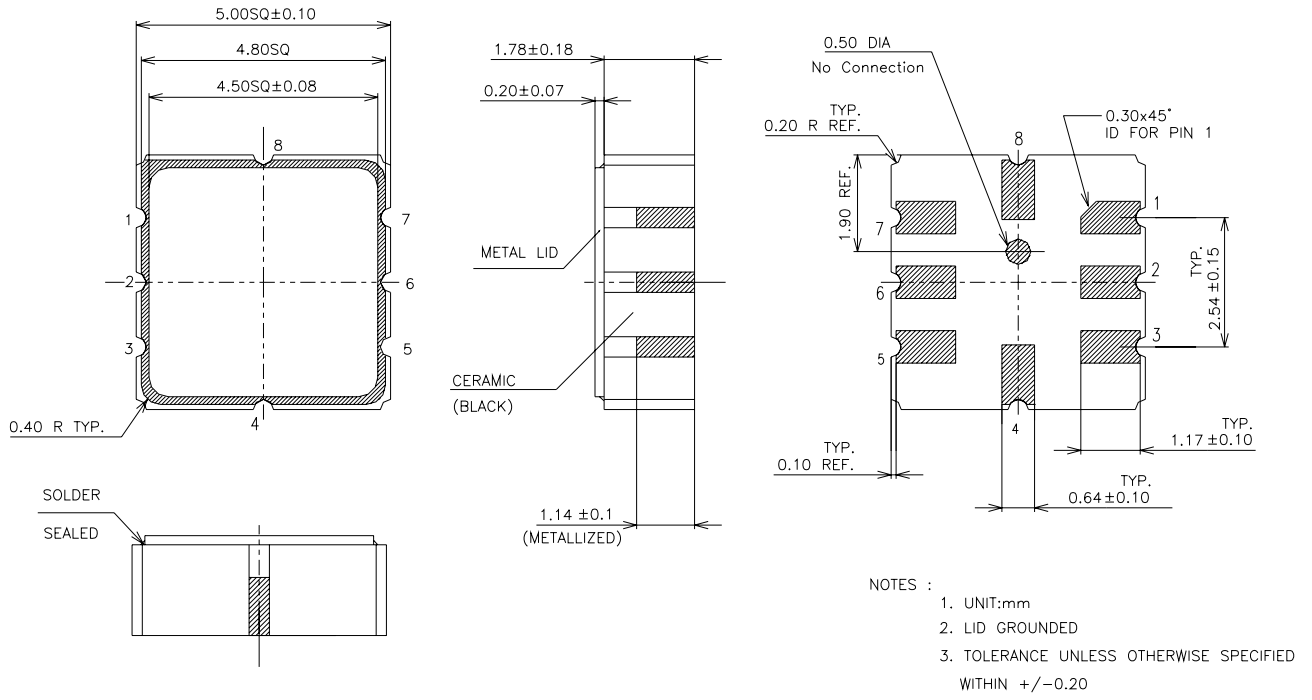

Fig 10: Hermetically Sealed Package Outline