

Datasheet

Fiber delivery system - kineFLEX®

The kineFLEX® is a robust laser beam delivery system for precision measurement applications. Designed around pre-focussed and integrated optical assemblies, the fiber is optically mode-matched to your laser parameters to achieve transmission efficiencies typically greater than 60%.

Single-mode fiber enables the user to decouple the laser beam astigmatism and dynamic beam pointing instability from the measurement application. Fiber also provides a convenient packaging solution by relocating sources of heat and by removing bulk components thereby reducing the number of optical surfaces from the beam alignment scheme.

The kineMATIX® is patented opto-mechanical mount used to align the laser beam into the single-mode fiber. The kinematic design of the kineMATIX coupler enables true 'Plug & Play' benefits for single mode and polarization-maintaining fiber designs. Sub-micron repeatability and sub-microradian stability mean systems can be aligned once only and are stable for multiple remove and insert operations, thus providing true modularity for instrument designs. The kineMATIX manipulator is included in the kineFLEX fiber delivery system.

Qioptiq fiber systems can be customized for exacting OEM specifications. Outputs can be configured to produce pure Gaussian profiles with extremely low wavefront error, as well as engineered spatial profiles and shapes.

Fiber systems may also be minituarized into custom OEM picoFLEX™ fiber designs. In the same way, the kineMATIX manipulator mount and fiber output mechanics can be customized to better suit the application. Contact us to discuss your requirements.

Product feature highlights:

- TEM₀₀ output - diffraction limited, Gaussian, spatially filtered output beam
- Extremely stable output beam, with class leading beam pointing stability at < 1μrad/ °C
- True modularity for instrument design: "Plug & Play"
- Highly insensitive to opto-mechanical thermal effects
- Truly co-linear beams for multiple laser lines
- Custom options available



Technical specification

Fibers for	Operating wavelengths (λ in nm)																Maximum input power (mW)	
Single-λ laser	405	445	458														25	
				473	488	515	520	532	561	594	633	640	660	670	730	780	830	852
Broadband- λ laser	← 405 - 640 →																100 ¹	
	← 488 - 640 →																100	

Operating performance		Units
Polarization ratio	≤ -20	dB
Throughput efficiency ²	≥ 65 (single wavelength fibers) ≥ 60 (broadband systems)	%
Fiber parameters		
Fiber length	1, 2, 3	m
Fiber protective jacket	Stainless steel, 5mm OD, standard	-
Collimated output beam		
Beam diameter	0.7 ± 0.1	mm
M Squared	≤ 1.1	-
Pointing stability	≤ 1	μrad/°C
Output collimator dimensions	Ø12 x 50	mm
Beam position	≤ 0.15	mm
Beam angle	≤ 0.5	mrad
Alternative connectorized output		
Polarization maintaining fiber	FCP (polarization keyed) FCP8, APC (polarization keyed and 8 degree polished)	-
Environmental conditions		
Storage temperature	10 to 50	°C
Operating pressure	Atmospheric	-
Operating temperature	10 to 40	°C
Operating humidity	Non-condensing	-

¹With maximum 25mW in the 405-460nm range. Maximum combined power 100mW.

²Assuming 0.7mm circularized input beam diameter.

See kineFLEX®-HPV-UV datasheet for wavelengths below 400 nm or input laser powers above 100mW CW. More wavelengths on request.

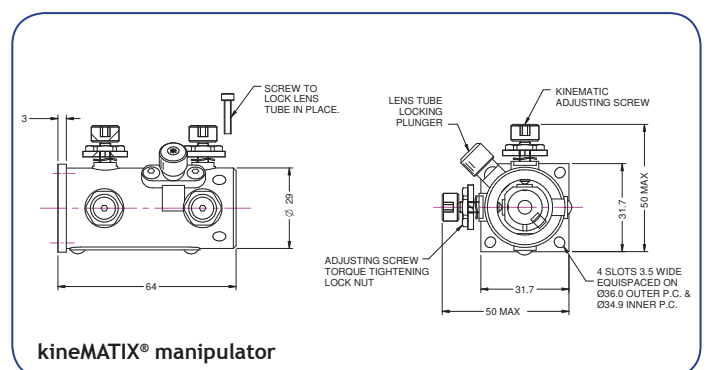

For further information please contact:

Mitchell Point, Ensign Way, Hamble, Hampshire, UK, SO31 4RF
 Email: sales.ham@excelitas.com
 Tel: +44 (0) 23 80 744 500 | Fax: +44 (0) 23 80 744 501
 www.qioptiq.com

