

# THCS251

35-bits GPIO or high speed Bus signal Transceiver

## General description

The THCS251 integrates Serializer and Deserializer onto a single chip, which supports general purpose input and output (GPIO) signals through two pairs of differential signal.

GPIO sampling clock is selectable from external reference clock or internal oscillator clock.

The 8B10B encoding and decoding adopted by THCS251 is easy to connect to optical / wireless communication devices with high robustness and DC balanced signal.

The built-in adaptive equalizer enables flexible cable selection.

## Application

The THCS251 can applicable to any systems which have many control signals between PCBs, for example Multi-function printers, Amusement machines, Factory Automation and TVs.

## Features

- Support up to 35-bits GPIO
- Not required to input GPIO sampling clock in internal oscillator clock mode
- Full duplex communication by two pairs of differential signal
- Output buffer open-drain or push-pull selectable
- Support up to 8-bits low speed GPIO in low power Standby mode
- Integrated adaptive equalizer for long or lossy media
- 8B10B encoding and decoding
- Configurable digital noise filter
- Error detection and indication
- External reference clock frequency: 9-100MHz
- Spread Spectrum Clock Generator to reduce EMI
- Operating single power supply voltage: 1.7 V - 3.6 V
- Wide range IO voltage: 1.7V - 3.6V
- Operating ambient temperature: -40°C to 85°C

## Block diagram

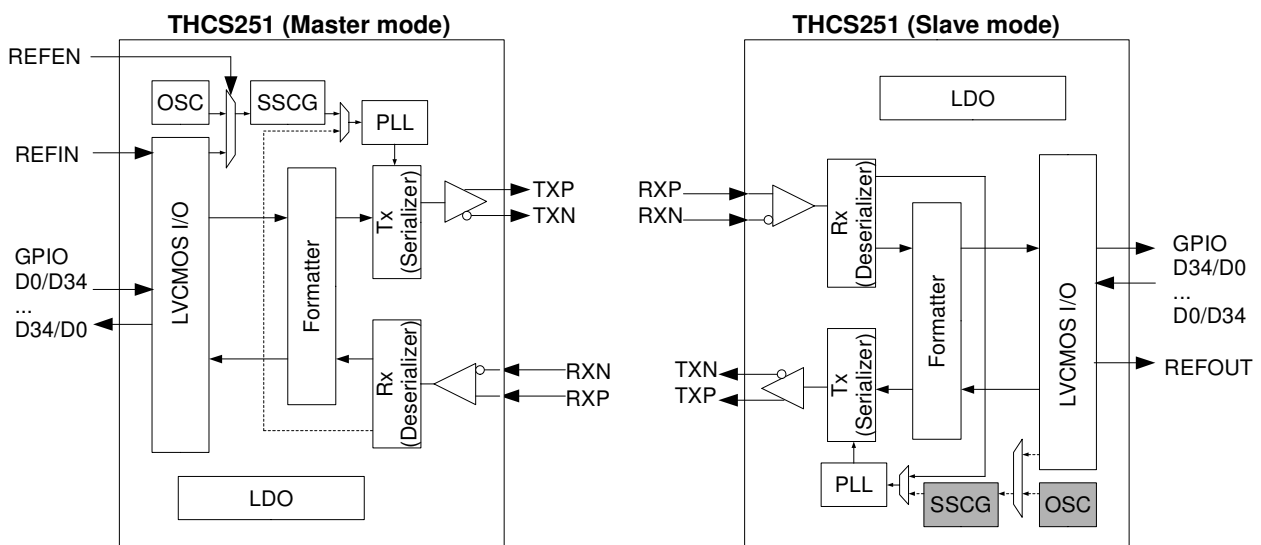

Contents page

General description.....	1
Application .....	1
Features .....	1
Block diagram .....	1
1. Pin configuration .....	3
2. Pin description.....	4
3. Absolute maximum ratings.....	8
4. Recommended operating conditions .....	8
5. Electrical characteristics.....	9
5.1. Current consumption .....	9
5.2. LVCMOS/Analog input DC specifications .....	10
5.3. LVCMOS AC characteristics.....	11
5.4. CML DC characteristics .....	14
5.5. CML AC characteristics .....	14
6. CML Line Eye diagrams .....	19
6.1. CML output Eye diagrams.....	19
6.2. CML input Eye diagrams .....	20
7. Function.....	21
7.1. Functional overview .....	21
7.2. Power supply .....	21
7.2.1. Internal regulator output/input function (CAPOUT, CAPINA, CAPINP) .....	21
7.3. Operating mode .....	21
7.4. Transmission mode.....	22
7.4.1. Full duplex Bi-directional transmission mode.....	22
7.4.2. Unidirectional transmission mode .....	24
7.5. IO configuration .....	25
7.5.1. Input and Output digital noise filter .....	25
7.5.2. LVCMOS output buffer type configuration.....	25
7.5.3. 5V Tolerant I/O.....	25
7.6. Sampling clock configuration.....	26
7.6.1. Sampling clock selection.....	26
7.6.2. Spread Spectrum Clock Generator (SSCG) and REFIN frequency.....	28
7.7. Error detection and indication .....	29
7.8. Standby mode .....	30
8. Package.....	31
Notices and Requests.....	32

1. **Pin configuration**

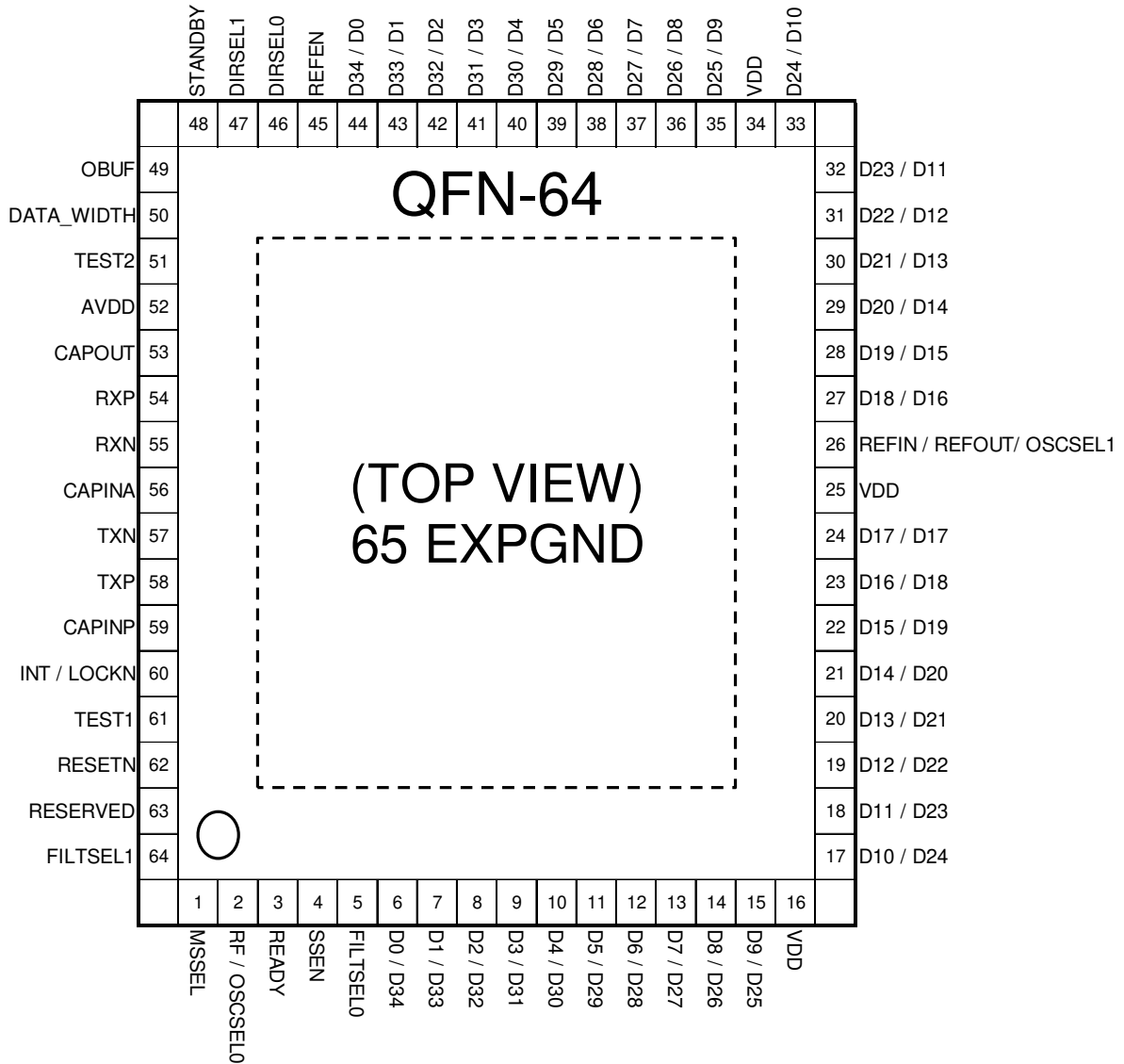

## 2. Pin description

Pin Name	Pin No.	Type	Description	Reference
TXP	58	CO	High-speed CML signal output	-
TXN	57	CO	High-speed CML signal output	-
RXP	54	CI	High-speed CML signal input	-
RXN	55	CI	High-speed CML signal input	-
RESETN	62	IL	Chip reset 0: Chip reset 1: Chip operation	-
STANDBY	48	IL	Standby mode entry 0: Normal mode operation 1: Standby mode operation	-
RESERVED	63	IL	RESERVED shall be tied to Ground.	-
MSSEL	1	IL	Master/Slave mode select 0: Master mode 1: Slave mode	-
FILTSEL1	64	IL	FILTSEL1: digital noise filter select	Table 5
DIRSEL0	46	IL	DIRSEL0: GPIO direction select	Table 2 Table 4
DIRSEL1	47	IL	DIRSEL1: GPIO direction select	Table 2 Table 4
OBUF	49	IL	Output buffer type select 0: open-drain 1: push-pull	-
REFEN	45	IL	Data sampling clock select (Master mode) 0: Internal oscillator clock 1: External reference clock	-
			CDR clock output enable (Slave mode) 0: REFOUT pin is Hi-Z state 1: CDR clock output from REFOUT pin	-
REFIN/ REFOUT/ OSCSEL1	26	B	REFIN: (Master mode) External Reference clock input	-
			REFOUT: (Slave mode) CDR clock output	-
			OSCSEL1: (Master mode) Oscillator clock frequency select	Table 10
			OSCSEL1: (Slave mode) Hi-Z	-
DATA_WIDTH	50	IL	GPIO Aggregator/Deaggregator data width select	Table 2 Table 4 Table 14
RF/ OSCSEL0	2	IL	RF:(Master mode) input clock edge select	Table 11 Figure 14
			RF:(Slave mode) output clock edge select	
			OSCSEL0: (Master mode) Oscillator clock frequency select	Table 10

Pin Name	Pin No.	Type	Description	Reference
			OSCSEL0: (Slave mode) Set to Low	
D0/ D34	6	BT	D0(Master mode): Data input D34(Slave mode): Data output	-
D1/ D33	7	BT	D1(Master mode): Data input D33(Slave mode): Data output	-
D2/ D32	8	BT	D2(Master mode): Data input D32(Slave mode): Data output	-
D3/ D31	9	BT	D3(Master mode): Data input D31(Slave mode): Data output	-
D4/ D30	10	B	D4(Master mode): Data input D30(Slave mode): Data output	-
D5/ D29	11	B	D5(Master mode): Data input D29(Slave mode): Data output	-
D6/ D28	12	B	D6(Master mode): Data input D28(Slave mode): Data output	-
D7/ D27	13	B	D7(Master mode): Data input D27(Slave mode): Data output	-
D8/ D26	14	B	D8(Master mode): Data input D26(Slave mode): Data output	-
D9/ D25	15	B	D9(Master mode): Data input D25(Slave mode): Data output	-
D10/ D24	17	B	D10(Master mode): Data input D24(Slave mode): Data output	-
D11/ D23	18	B	D11(Master mode): Data input D23(Slave mode): Data output	-
D12/ D22	19	B	D12(Master mode): Data input D22(Slave mode): Data output	-
D13/ D21	20	B	D13(Master mode): Data input D21(Slave mode): Data output	-
D14/ D20	21	B	D14(Master mode): Data input/output D20(Slave mode): Data input/output	-
D15/ D19	22	B	D15(Master mode): Data input/output D19(Slave mode): Data input/output	-
D16/ D18	23	B	D16(Master mode): Data input/output D18(Slave mode): Data input/output	-
D17/ D17	24	B	D17(Master mode): Data input/output D17(Slave mode): Data input/output	-
D18/ D16	27	B	D18(Master mode): Data input/output D16(Slave mode): Data input/output	-
D19/ D15	28	B	D19(Master mode): Data input/output D15(Slave mode): Data input/output	-
D20/ D14	29	B	D20(Master mode): Data input/output D14(Slave mode): Data input/output	-
D21/ D13	30	B	D21(Master mode): Data input/output D13(Slave mode): Data input/output	-
D22/ D12	31	B	D22(Master mode): Data input/output D12(Slave mode): Data input/output	-

Pin Name	Pin No.	Type	Description	Reference
D23/ D11	32	B	D23(Master mode): Data input/output D11(Slave mode): Data input/output	- -
D24/ D10	33	B	D24(Master mode): Data input/output D10(Slave mode): Data input/output	- -
D25/ D9	35	B	D25(Master mode): Data input/output D9(Slave mode): Data input/output	- -
D26/ D8	36	B	D26(Master mode): Data input/output D8(Slave mode): Data input/output	- -
D27/ D7	37	B	D27(Master mode): Data input/output D7(Slave mode): Data input/output	- -
D28/ D6	38	B	D28(Master mode): Data input/output D6(Slave mode): Data input/output	- -
D29/ D5	39	B	D29(Master mode): Data input/output D5(Slave mode): Data input/output	- -
D30/ D4	40	B	D30(Master mode): Data input/output D4(Slave mode): Data input/output	- -
D31/ D3	41	BT	D31(Master mode): Data input/output D3(Slave mode): Data input/output	- -
D32/ D2	42	BT	D32(Master mode): Data input/output D2(Slave mode): Data input/output	- -
D33/ D1	43	BT	D33(Master mode): Data input/output D1(Slave mode): Data input/output	- -
D34/ D0	44	BT	D34(Master mode): Data input/output D0(Slave mode): Data input/output	- -
SSEN	4	BL	SSEN(Master mode): SSCG PLL enable 0: SSCG PLL is disabled 1: SSCG PLL is enabled SSEN(Slave mode): Set to Low	-
FILTSEL0	5	BL	FILTSEL0: digital noise filter select	Table 5
INT/ LOCKN	60	BO	INT: Interrupt output when READY=1 0: Error occurred 1(pull-up): No Error LOCKN(Master mode): Lock detect input 0: Lock state 1(pull-up): Unlock state LOCKN(Slave mode): Lock detect output 0: Lock state 1(pull-up): Unlock state	- - -
READY	3	B	CML Link communication status 0: Unlock state 1: Lock state	-
TEST1	61	IL	TEST1 shall be tied to Ground.	-
TEST2	51	AI	TEST2 shall be tied to Ground.	-
CAPOUT	53	PWR	Decoupling capacitor Pin, 1.2V output.	Figure 9
CAPINA	56	PWR	1.2V Analog power supply input.	Figure 9

Pin Name	Pin No.	Type	Description	Reference
CAPINP	59	PWR	1.2V Analog power supply input.	Figure 9
VDD	16 25 34	PWR	1.7-3.6V Digital power supply input for LVCMOS I/O.	-
AVDD	52	PWR	1.7-3.6V Analog power supply input for on-chip regulator.	Figure 9
EXPGND	65	GND	Exposed Pad Ground. Must be tied to the PCB ground plane through an array of vias.	-

#### Pin Type definition

##### Analog Buffer

CO : CML Output buffer

CI : CML Input buffer

AI : Analog Input buffer

##### LVCMOS buffer

IL : Low speed schmitt trigger LVCMOS Input buffer

B : LVCMOS Bi-directional buffer

BO : Open-drain LVCMOS Bi-directional buffer

BL : Low speed 5V tolerant schmitt trigger LVCMOS Bi-directional buffer

BT : Low speed 5V tolerant LVCMOS Bi-directional buffer

##### Power/Ground

PWR : Power supply

GND : Ground

### 3. Absolute maximum ratings

Parameter	Min	Typ	Max	Unit
Supply voltage(VDD,AVDD)	-0.3	-	4.0	V
LVC MOS input voltage	-0.3	-	VDD+0.3	V
LVC MOS output voltage	-0.3	-	VDD+0.3	V
5V tolerant Bi-directional buffer input voltage	-0.3	-	VDD+2.5	V
5V tolerant Bi-directional buffer output voltage	-0.3	-	VDD+2.5	V
Open-drain output voltage	-0.3	-	4.0	V
CML receiver input voltage	-0.3	-	CAPINA+0.3	V
CML transmitter output voltage	-0.3	-	CAPINP+0.3	V
Output current	-50	-	50	mA
Storage temperature	-55	-	125	°C
Junction temperature	-	-	125	°C
Reflow peak temperature/time	-	-	260/10	°C/sec
Theta-ja (Junction-to-Ambient)	29.1 [*1]			°C/W
Psi-jt (Junction-to-Top of Package)	1.1 [*1]			°C/W
Maximum power dissipation @+25°C	3.4[*1]			W

“Absolute maximum ratings” are those values beyond which the safety of the device cannot be guaranteed.

They are not meant to imply that the device should be operated at these limits. The tables of “Electrical Characteristics” specify conditions for device operation.

\*1: Thermal parameters are not guaranteed value. This value assists board and system level designers.

### 4. Recommended operating conditions

Parameter	Min	Typ	Max	Unit
Supply voltage(VDD,AVDD)	1.7	-	3.6	V
Operating ambient temperature	-40	-	85	°C

VDD and AVDD supply voltage shall be the same voltage.



## 5. Electrical characteristics

### 5.1. Current consumption

Symbol	Parameter	Pin Type	Condition	Min	Typ	Max	Unit
Idd_w1	Normal mode current Low current use case [*1]	PWR	AVDD=3.3V VDD=3.3V	-	80	-	mA
Idd_w2	Normal mode current High current use case [*2]	PWR	AVDD=3.3V VDD=3.3V	-	260	-	mA
Idda_stby	Standby mode current	PWR	AVDD=3.3V VDD=3.3V	-	4	-	mA
Idda_slp	Sleep mode current	PWR	AVDD=3.3V VDD=3.3V	-	3	-	mA
Idda_rst	Reset mode current	PWR	AVDD=3.3V VDD=3.3V	-	3	-	mA

PWR : Power supply

\*1: Master mode of Unidirectional transmission mode, 35-bits GPIO input, 80MHz of REFIN clock

\*2: Slave mode of Unidirectional transmission mode, 35-bits GPIO output, 80MHz of REFOUT clock

## 5.2. LVC MOS/Analog input DC specifications

Symbol	Parameter	Pin Type	Condition	Min	Typ	Max	Unit
VIH	High level input voltage	B,BT,BO	$1.7V \leq VDD < 2.0V$	0.65 VDD	-	VDD	V
			$2.0V \leq VDD < 3.0V$	0.70 VDD	-	VDD	V
			$3.0V \leq VDD \leq 3.6V$	2.0	-	VDD	V
		IL,BL	$1.7V \leq VDD \leq 3.6V$	0.70 VDD	-	VDD	V
VIL	Low level input voltage	B,BT,BO	$1.7V \leq VDD < 2.0V$	0	-	0.35 VDD	V
			$2.0V \leq VDD < 3.0V$	0	-	0.30 VDD	V
			$3.0V \leq VDD \leq 3.6V$	0	-	0.8	V
		IL,BL	$1.7V \leq VDD \leq 3.6V$	0	-	0.30 VDD	V
		AI	$1.7V \leq VDD \leq 3.6V$	0	-	0.15 VDD	V
VOH	High level output voltage	B,BT,BL	$1.7V \leq VDD < 2.0V$ IOH=-2mA	VDD - 0.30	-	VDD	V
			$2.0V \leq VDD \leq 3.6V$ IOH=-4mA	VDD - 0.45	-	VDD	V
VOL	Low level output voltage	B,BT,BL	$1.7V \leq VDD < 2.0V$ IOL=2mA	0	-	0.30	V
			$2.0V \leq VDD \leq 3.6V$ IOL=4mA	0	-	0.45	V
		BO	$1.7V \leq VDD \leq 3.6V$ IOL=2mA	0	-	0.27	V
I <sub>IH</sub>	Input leak current high	IL	VIN=VDD	-10	-	10	μA
I <sub>IL</sub>	Input leak current low	IL	VIN=0V	-10	-	10	μA
I <sub>OZH</sub>	Output leak current high in Hi-Z state	B,BT,BL,BO	VIN=VDD	-10	-	10	μA
I <sub>OZL</sub>	Output leak current low in Hi-Z state	B,BT,BL,BO	VIN=0V	-10	-	10	μA

AI : Analog Input buffer

IL : Low speed schmitt trigger LVC MOS Input buffer

B : LVC MOS Bi-directional buffer

BO : Open-drain LVC MOS Bi-directional buffer

BL : Low speed 5V tolerant schmitt trigger LVC MOS Bi-directional buffer

BT : Low speed 5V tolerant LVC MOS Bi-directional buffer

### 5.3. LVC MOS AC characteristics

Symbol	Parameter	Condition	Min	Typ	Max	Unit	
tRSN	RESETN low time	-	3	-	-	us	
tTCIP	REFIN period	DATA_WIDTH=0	10	-	66.6	ns	
		DATA_WIDTH=1	12.5	-	111	ns	
tTCH	REFIN high time	-	0.35 tTCIP	0.5 tTCIP	0.65 tTCIP	ns	
tTCL	REFIN low time	-	0.35 tTCIP	0.5 tTCIP	0.65 tTCIP	ns	
tTS	Data input setup to REFIN	Pin type: B	1.7V≤VDD≤3.6V	2.0	-	-	ns
			1.7V≤VDD<2.25V	25	-	-	ns
		Pin type: BT	2.25V≤VDD≤2.75V	2.5	-	-	ns
			2.75V<VDD≤3.6V	2.0	-	-	ns
tTH	Data input hold to REFIN	-	1.0	-	-	ns	
tTPD	Power on to RESETN high delay	-	0	-	-	ns	
tOSC	Internal oscillator clock period	OSCSEL1=0 OSCSEL0=0	41.67	50	62.5	ns	
		OSCSEL1=1 OSCSEL0=0	20.84	25	31.25	ns	
		OSCSEL1=1 OSCSEL0=1	10.42	12.5	15.62	ns	
tDCP	Data sampling clock period	REFEN=0	-	tOSC	-	ns	
		REFEN=1	-	tTCIP	-	ns	
tFLTCK	Noise filter clock period	REFEN=0	10.42	12.5	15.62	ns	
		REFEN=1	-	tTCIP	-	ns	
tTCD	Input data to output data delay (Master mode to Slave mode)	SSEN=0	FILTSEL1=0 FILTSEL0=0	12 tDCP	-	25 tDCP	ns
			FILTSEL1=0 FILTSEL0=1	19 tDCP	-	35 tDCP	ns
			FILTSEL1=1 FILTSEL0=0	24 tDCP	-	43 tDCP	ns
			FILTSEL1=1 FILTSEL0=1	34 tDCP	-	59 tDCP	ns
		SSEN=1	FILTSEL1=0 FILTSEL0=0	57 tDCP	-	110 tDCP	ns
			FILTSEL1=0 FILTSEL0=1	64 tDCP	-	120 tDCP	ns
			FILTSEL1=1 FILTSEL0=0	69 tDCP	-	128 tDCP	ns
			FILTSEL1=1 FILTSEL0=1	79 tDCP	-	144 tDCP	ns
tRCP	REFOUT period	-	-	tDCP	-	ns	
tRCH	REFOUT high time	-	-	0.5 tDCP	-	ns	
tRCL	REFOUT low time	-	-	0.5 tDCP	-	ns	
tDOUT	Data output period	-	-	tDCP	-	ns	
tRS	Data output setup to REFOUT	-	0.45 tDCP - 0.675	-	-	ns	
tRH	Data output hold to REFOUT	-	0.45 tDCP - 2.175	-	-	ns	
tRCD	Input data to output data delay (Slave mode to Master mode)	FILTSEL1=0 FILTSEL0=0	12 tDCP	-	25 tDCP	ns	
		FILTSEL1=0 FILTSEL0=1	19 tDCP	-	35 tDCP	ns	
		FILTSEL1=1 FILTSEL0=0	24 tDCP	-	43 tDCP	ns	
		FILTSEL1=1	34 tDCP	-	59 tDCP	ns	

Symbol	Parameter	Condition	Min	Typ	Max	Unit
		FILTSEL0=1				
tRRDY	RESETN high to READY high delay	-	0	-	10	ms
tNRDY	STANDBY low to READY high delay	-	0	-	10	ms
tSRDY	STANDBY high to READY high delay	-	0	-	10	ms
tSSKW	STANDBY high of Master mode and Slave mode skew margin	-	-400	-	+400	us
tTLH	Clock and Data output low to high transition time	Clock	-	-	2.1	ns
		Data(Pin type=B)	-	-	4.2	ns
		Data(Pin type=BT)	-	-	5.9	ns
tTHL	Clock and data output high to low transition time	Clock	-	-	2.1	ns
		Data(Pin type=B)	-	-	4.3	ns
		Data(Pin type=BT)	-	-	6.1	ns

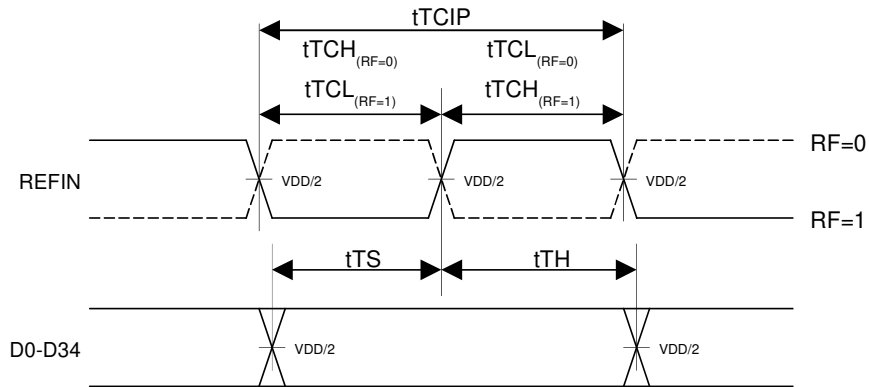
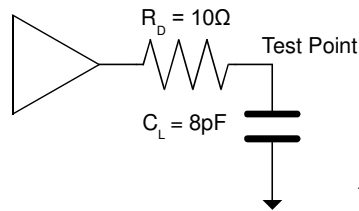

Figure 1 LVC MOS input timing diagram



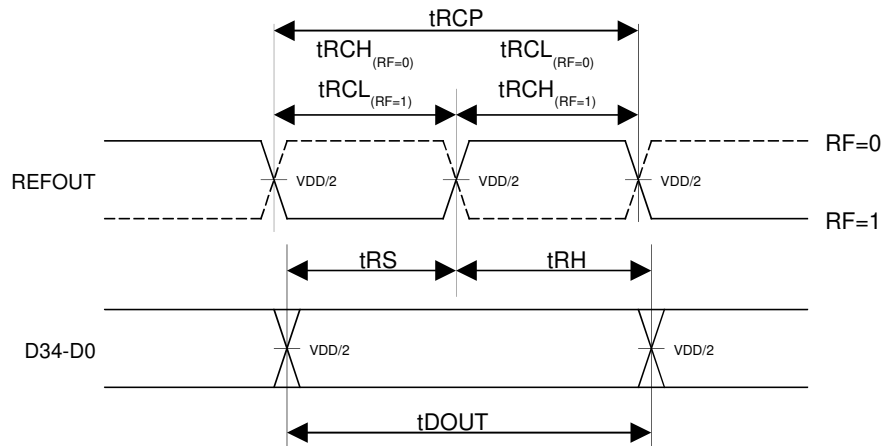

Figure 2 LVC MOS output timing diagram

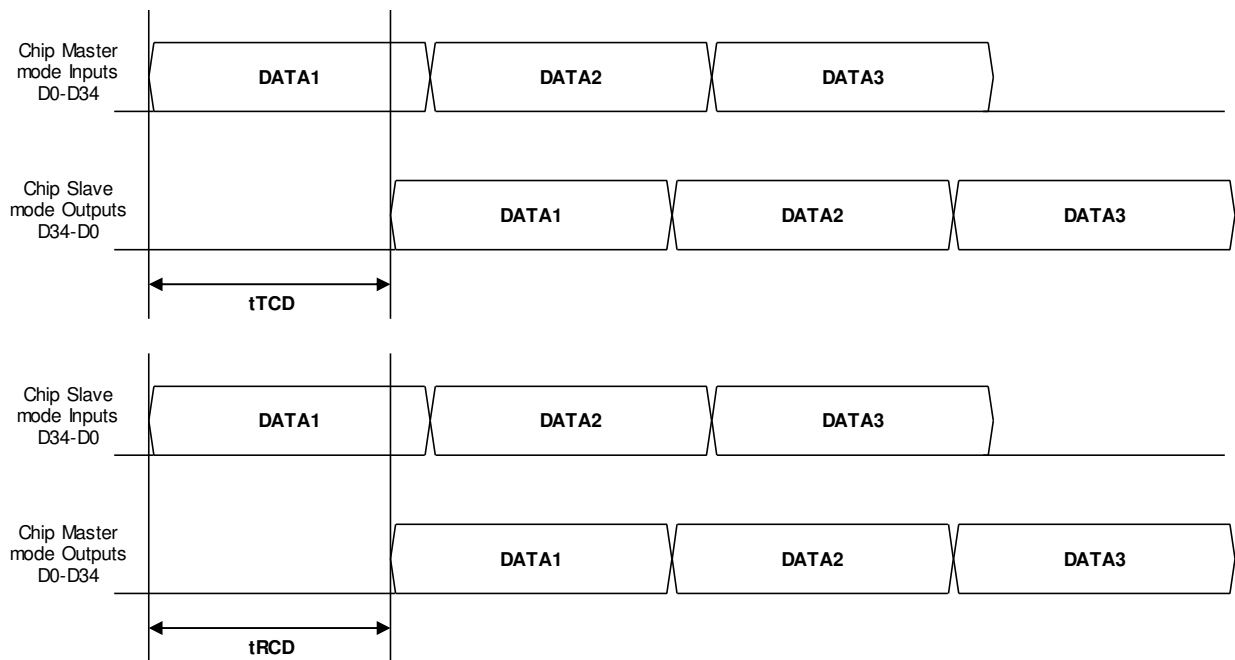

Figure 3 GPIO Input to Output delay timing diagram

#### 5.4. CML DC characteristics

Symbol	Parameter	Condition	Min	Typ	Max	Unit
VTOD	CML differential output peak to peak signal	-	600	800	1000	mVpp
VTOC	CML common mode output voltage	-	-	1200 - 0.5 VTOD	-	mV
ITOH	CML output leak current high	RESETN=0 TXP/N=CAPINA	-30	-	30	uA
ITOS	CML output short current	RESETN=0 TXP/N=0V	-80	-	-	mA
VRTH	CML differential input high threshold	-	-	-	50	mV
VRTL	CML differential input low threshold	-	-50	-	-	mV
IRIH	CML input leak current high	RESETN=0 RXP/N=CAPINA	-10	-	10	uA
IRIL	CML input leak current low	RESETN=0 RXP/N=0V	-10	-	10	uA
IRRIH	CML input current high	RXP/N=CAPINA	-	-	2	mA
IRRIL	CML input current low	RXP/N=0V	-6	-	-	mA
RRIN	CML differential input resistance	-	80	100	120	Ω

#### 5.5. CML AC characteristics

Symbol	Parameter	Condition	Min	Typ	Max	Unit
tTRF	CML output rise and fall time (20%-80%)	-	50	-	150	ps
tTPLLO	RESETN=1 to CML output delay	-	-	-	10	ms
tTPLL1	RESETN=0 to CML output high fix delay	-	-	-	500	ns
tTNP0	READY low to training pattern output delay	-	-	-	100	us
tTBIT	Output unit interval	DATA_WIDTH=0	-	tDCP±30	-	ns
		DATA_WIDTH=1	-	tDCP±50	-	ns
tRBIT	Input unit interval	-	250	-	2222	ps
tRPLL0	Training pattern input to LOCKN low delay	Unidirectional mode	-	-	10	ms
tRPLL1	RESETN low to LOCKN High delay	Unidirectional mode	-	-	10	us
tRLCK0	LOCKN low to data output delay	Unidirectional mode	-	-	5	ms

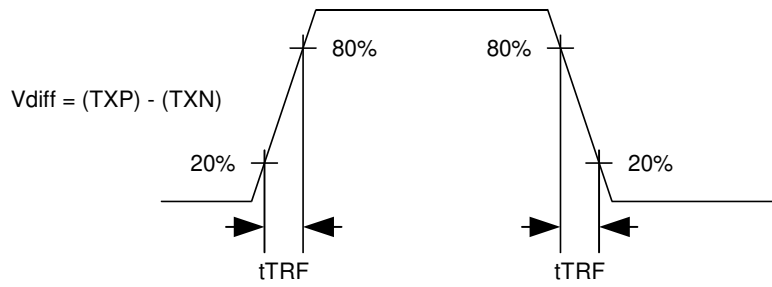
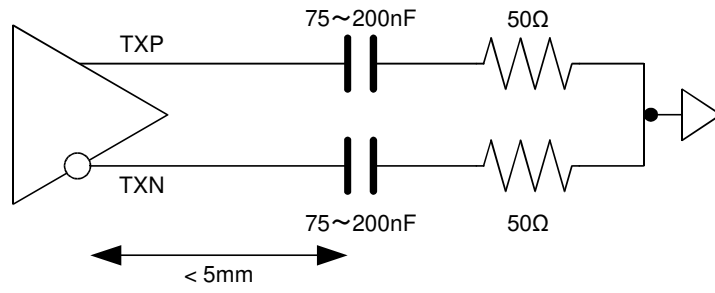

Figure 4 CML output AC characteristics diagram

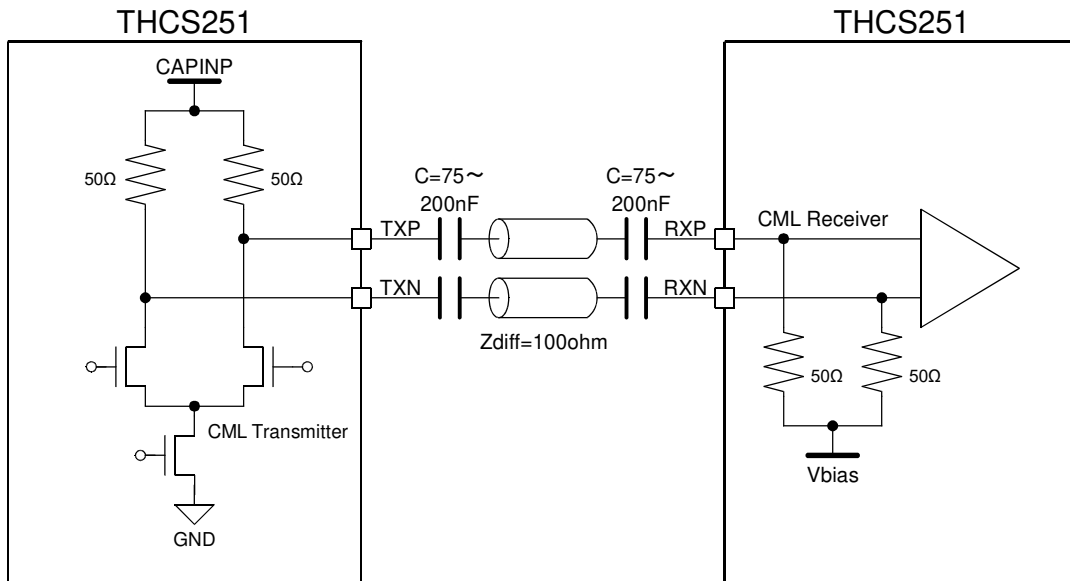
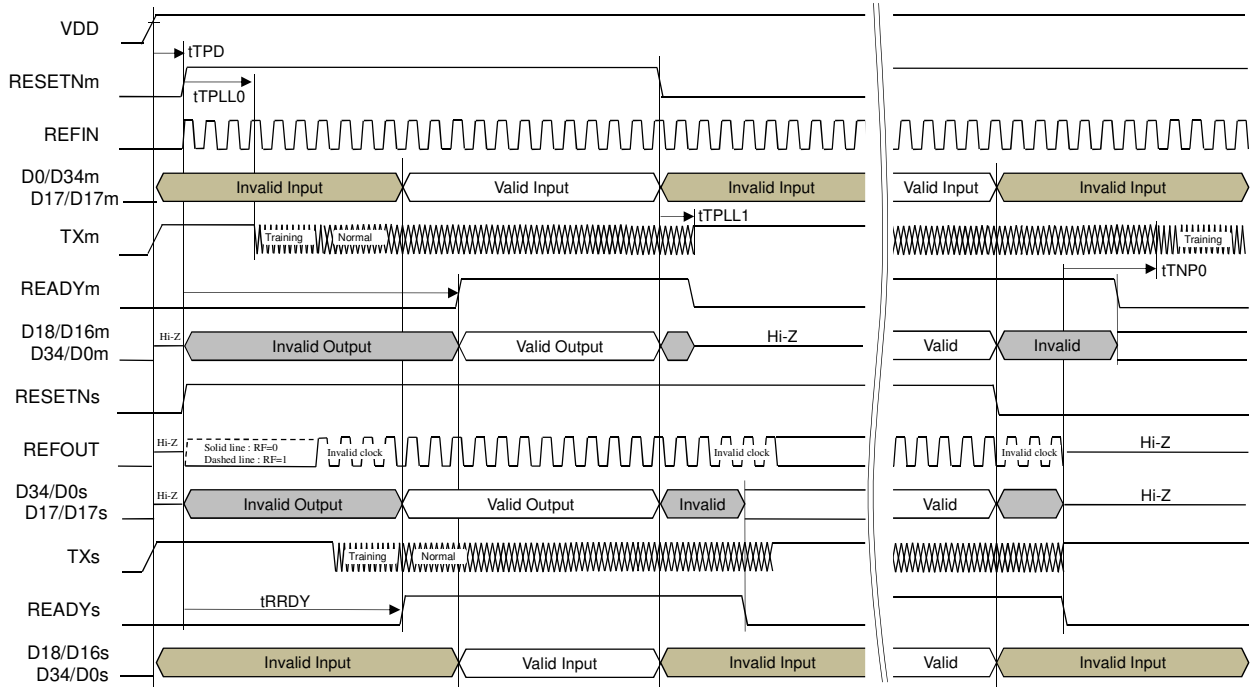
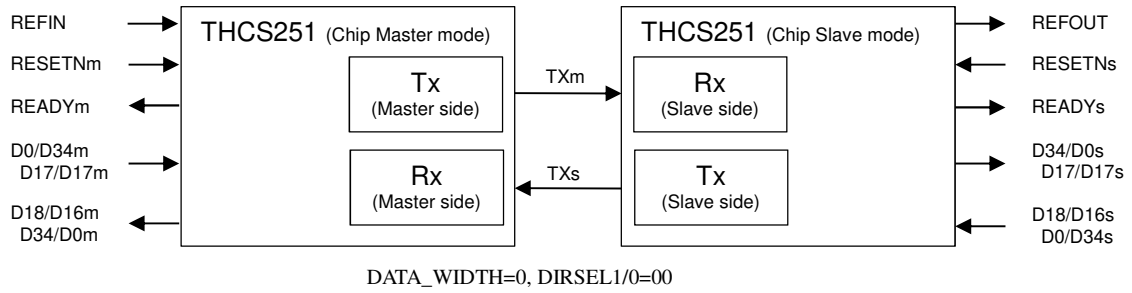
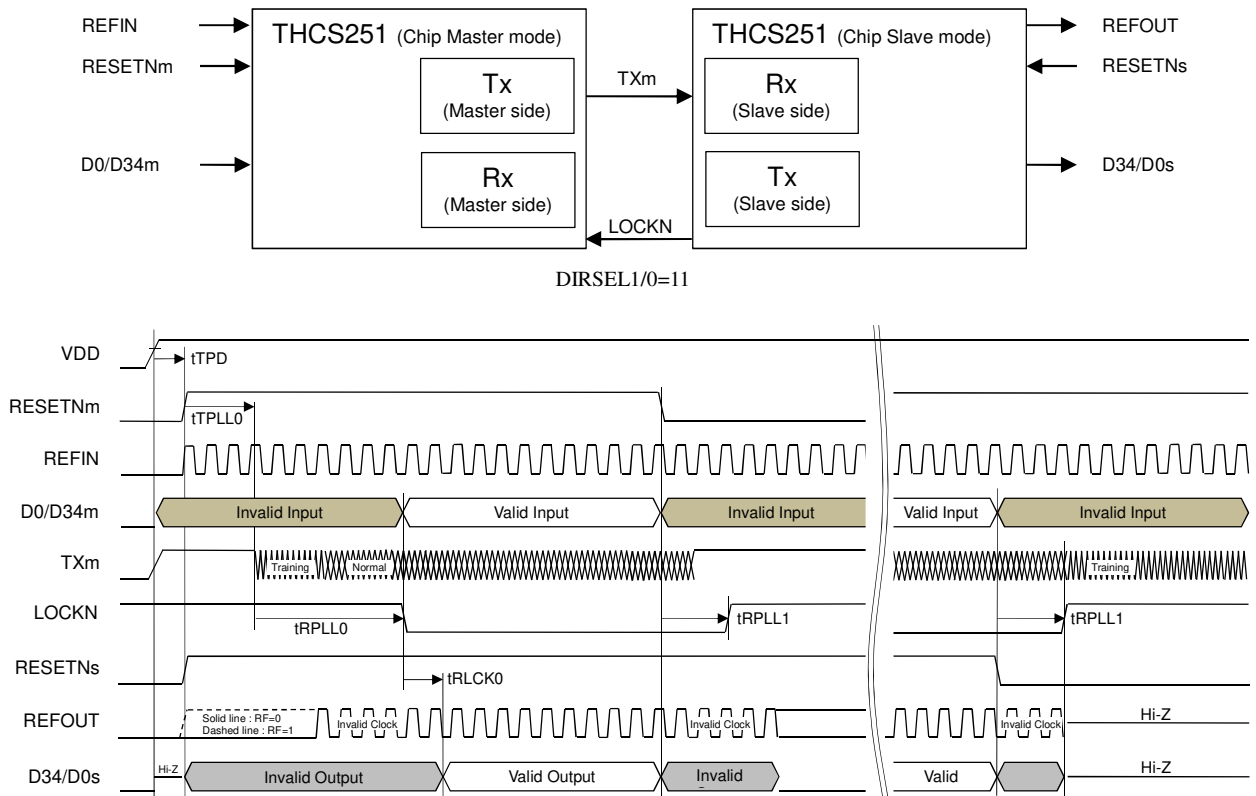

Figure 5 CML buffer equivalent circuit

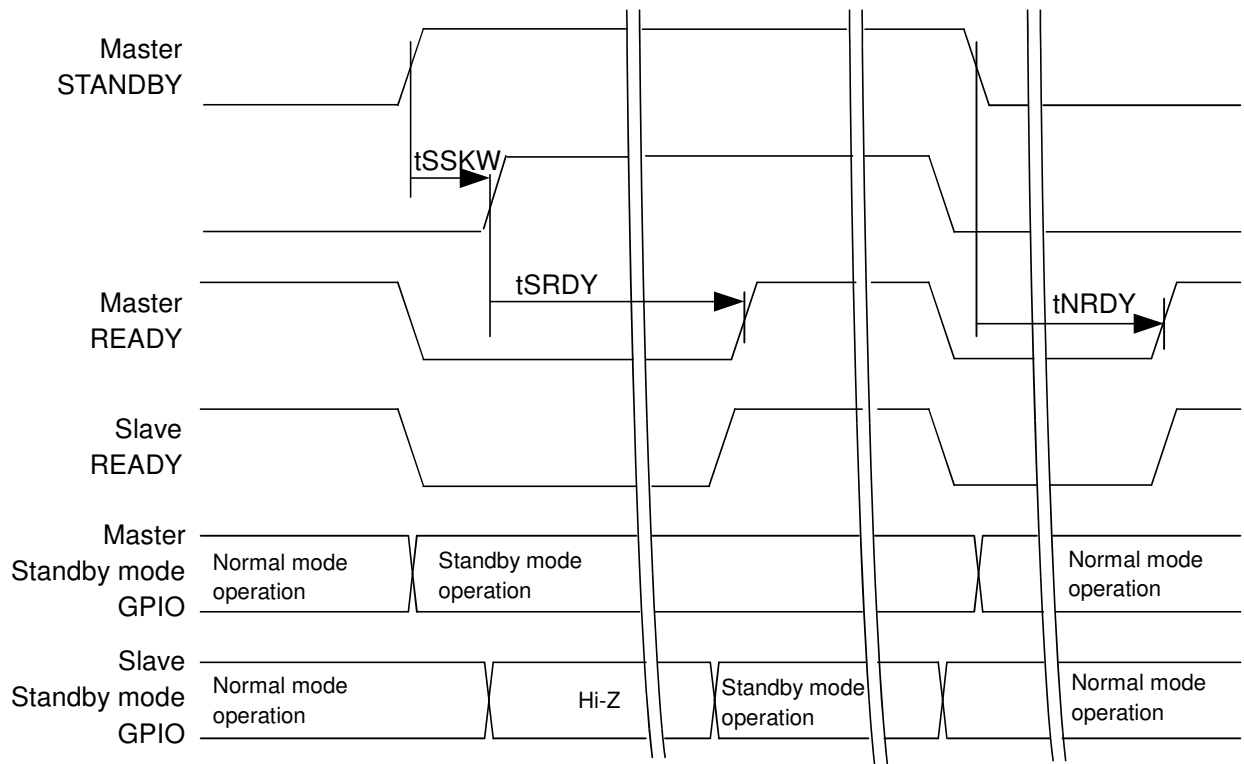

**Figure 6 GPIO/CML Bi-directional mode Power on & Reset timing diagram**





**Figure 7 GPIO/CML Unidirectional mode lock & unlock timing diagram**



**Figure 8 Standby mode timing diagram**

**6. CML Line Eye diagrams**

**6.1. CML output Eye diagrams**

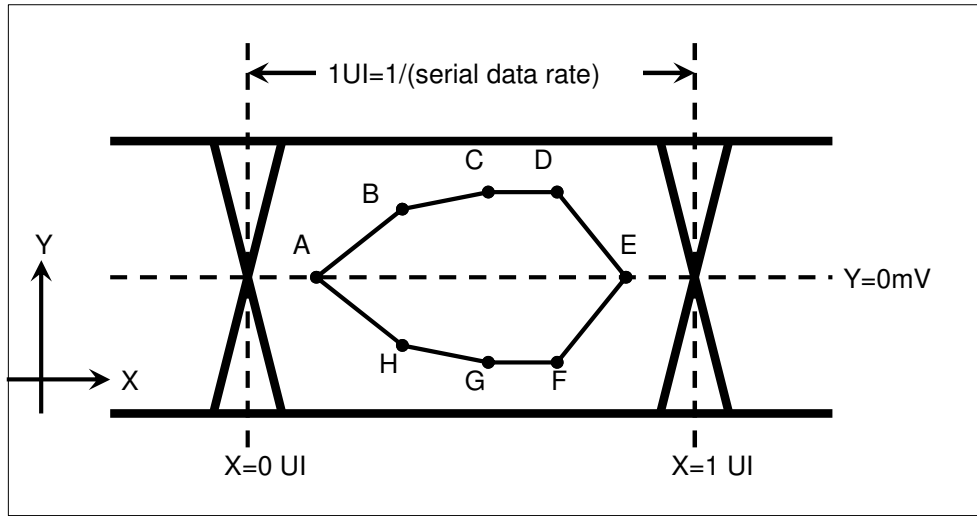

	X[UI]	Y[mV]
A	0.15	0
B	0.355	140
C	0.5	175
D	0.645	175
E	0.85	0
F	0.645	-175
G	0.5	-175
H	0.355	-140

**6.2. CML input Eye diagrams**

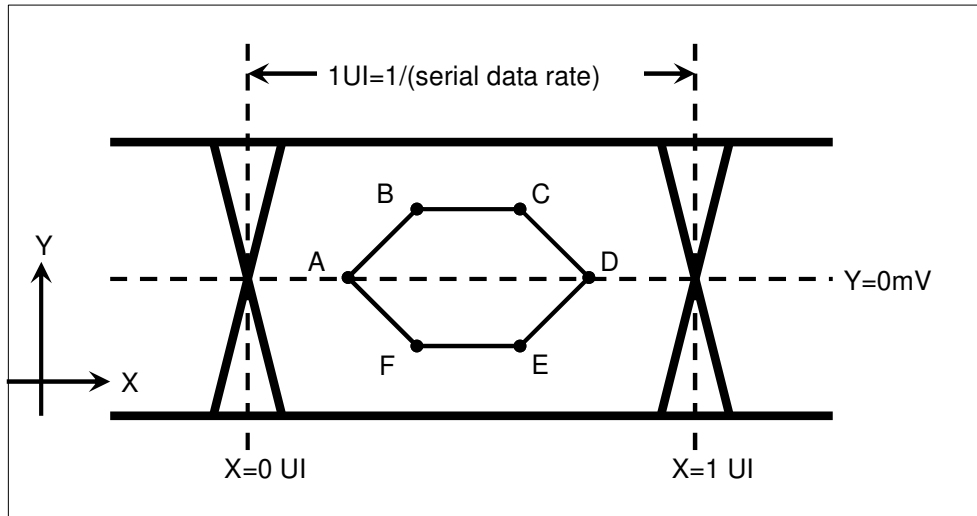

	X[UI]	Y[mV]
A	0.25	0
B	0.3	50
C	0.7	50
D	0.75	0
E	0.7	-50
F	0.3	-50

**7. Function**

**7.1. Functional overview**

With high speed CML Serializer and Deserializer integrated onto a single chip, THCS251 enables Aggregation/Deaggregation up to 35-bits parallel General-Purpose I/O (GPIO) signal through full-duplex communication by two pairs of differential signal with minimal external components. THCS251 supports up to 8-bits low speed GPIO signal in low power Standby mode. It does not require any external clock generators e.g. a crystal oscillator. A pair of THCS251 enables to monitor and control peripheral devices via GPIOs. In case communication errors occur, they keep the GPIO signals and report by an interrupt signal.

**7.2. Power supply**

**7.2.1. Internal regulator output/input function (CAPOUT, CAPINA, CAPINP)**

An internal regulator produces 1.2V (CAPOUT) only for internal use. It shall not be used for any other external loads. Bypass CAPOUT to GND with 10uF as a power supply pin. Bypass AVDD to GND with >10uF. CAPINP and CAPINA supply reference voltage for internal analog circuits. Bypass CAPINP/CAPINA to GND with 0.1uF as power supply pins to reduce high frequency noise. CAPOUT, CAPINA and CAPINP must be tied together as Figure 9.

It is recommended to place ferrite bead for AVDD pins to reduce noise as Figure 9.

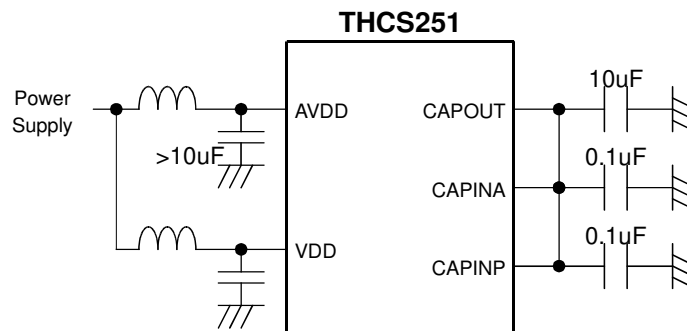

**Figure 9 Connection of CAPOUT, CAPINA, CAPINP and decoupling capacitor**

**7.3. Operating mode**

Table 1 shows operating mode setting.

**Table 1 Operating mode setting**

Operating mode	Setting		description
	RESETN	STANDBY	
Reset	0	-	Chip reset All outputs are Hi-Z
Normal	1	0	Normal operating mode
Standby	1	1	Low power and low frequency sampling rate transmission through up to 8-bits GPIO.

**7.4. Transmission mode**

THCS251 has a Bi-directional transmission mode with full-duplex communication and a Unidirectional communication mode.

**7.4.1. Full duplex Bi-directional transmission mode**

THCS251 can be used a pair of Master mode and Slave mode. Master mode samples data by external reference clock or internal oscillator clock. Slave mode samples data by CDR (Clock Data Recovery) clock generated by Rx. Same configuration of MSSEL between Master mode and Slave mode is prohibited. See Figure 10.

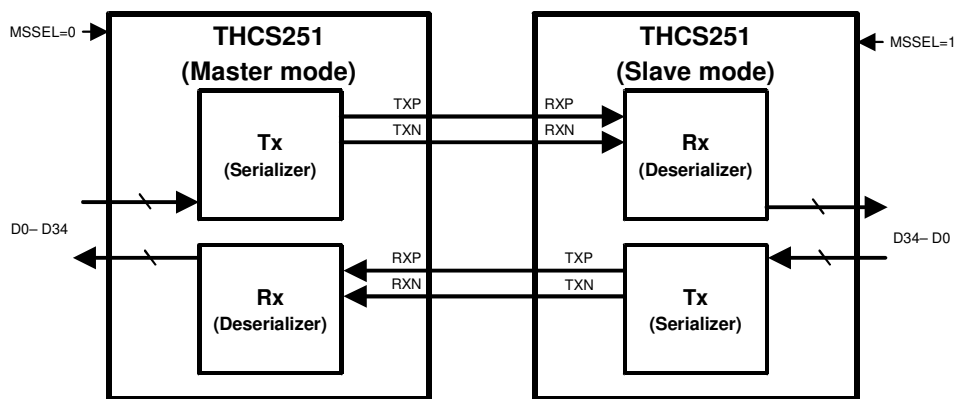

**Figure 10 Setting for Bi-directional transmission mode**

**Table 2 Common setting of Master/Slave mode for Full duplex mode**

Use case	A-1	A-2	A-3	B-1	B-2	B-3	
<b>Setting</b>							
DATA_WIDTH	0	0	0	1	1	1	
DIRSEL1, DIRSEL0	00	01	10	00	01	10	
<b>Mode</b>							
Downstream bit count	18	21	14	24	30	34	
Upstream bit count	17	14	21	11	5	1	
CML line data rate	External reference clock mode: 1/tTCIP x 30 Internal oscillator clock mode: 1/tOSC x 30			External reference clock mode: 1/tTCIP x 50 Internal oscillator clock mode: 1/tOSC x 50			
<b>Data pin for Master mode</b>							<b>Data pin for Slave mode</b>
D0/D34	=>	=>	=>	=>	=>	=>	D34/D0
D1/D33	=>	=>	=>	=>	=>	=>	D33/D1
D2/D32	=>	=>	=>	=>	=>	=>	D32/D2
D3/D31	=>	=>	=>	=>	=>	=>	D31/D3
D4/D30	=>	=>	=>	=>	=>	=>	D30/D4
D5/D29	=>	=>	=>	=>	=>	=>	D29/D5
D6/D28	=>	=>	=>	=>	=>	=>	D28/D6
D7/D27	=>	=>	=>	=>	=>	=>	D27/D7
D8/D26	=>	=>	=>	=>	=>	=>	D26/D8
D9/D25	=>	=>	=>	=>	=>	=>	D25/D9
D10/D24	=>	=>	=>	=>	=>	=>	D24/D10
D11/D23	=>	=>	=>	=>	=>	=>	D23/D11
D12/D22	=>	=>	=>	=>	=>	=>	D22/D12
D13/D21	=>	=>	=>	=>	=>	=>	D21/D13
D14/D20	=>	=>	<=>	=>	=>	=>	D20/D14
D15/D19	=>	=>	<=>	=>	=>	=>	D19/D15
D16/D18	=>	=>	<=>	=>	=>	=>	D18/D16
D17/D17	=>	=>	<=>	=>	=>	=>	D17/D17
D18/D16	<=>	=>	<=>	=>	=>	=>	D16/D18
D19/D15	<=>	=>	<=>	=>	=>	=>	D15/D19
D20/D14	<=>	=>	<=>	=>	=>	=>	D14/D20
D21/D13	<=>	<=>	<=>	=>	=>	=>	D13/D21
D22/D12	<=>	<=>	<=>	=>	=>	=>	D12/D22
D23/D11	<=>	<=>	<=>	=>	=>	=>	D11/D23
D24/D10	<=>	<=>	<=>	<=>	=>	=>	D10/D24
D25/D9	<=>	<=>	<=>	<=>	=>	=>	D9/D25
D26/D8	<=>	<=>	<=>	<=>	=>	=>	D8/D26
D27/D7	<=>	<=>	<=>	<=>	=>	=>	D7/D27
D28/D6	<=>	<=>	<=>	<=>	=>	=>	D6/D28
D29/D5	<=>	<=>	<=>	<=>	=>	=>	D5/D29
D30/D4	<=>	<=>	<=>	<=>	<=>	=>	D4/D30
D31/D3	<=>	<=>	<=>	<=>	<=>	=>	D3/D31
D32/D2	<=>	<=>	<=>	<=>	<=>	=>	D2/D32
D33/D1	<=>	<=>	<=>	<=>	<=>	=>	D1/D33
D34/D0	<=>	<=>	<=>	<=>	<=>	<=>	D0/D34

"=>" means Downstream (GPIO input in Master mode and GPIO output in Slave mode).

"<=>" means Upstream (GPIO input in Slave mode and GPIO output in Master mode).

Start communication after setting each "Use case" in both Master/Slave.

**7.4.2. Unidirectional transmission mode**

THCS251 operates in Unidirectional transmission mode by setting DIRSEL1=1 and DIRSEL0=1. A pair of differential signal from Slave mode to Master mode shall not be connected. LOCKN connection from Slave mode to Master mode is required.

**Table 3 INT/LOCKN function in Unidirectional transmission mode**

Setting			LOCKN	Description
DIRSEL1	DIRSEL0	MSSEL		
1	1	0	LOCKN Input	Master mode
		1	LOCKN Output (open-drain)	Slave mode

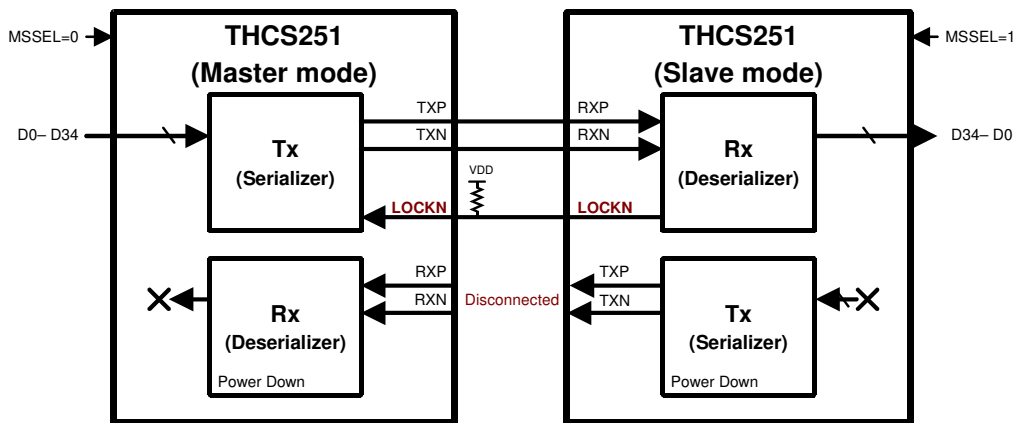

**Figure 11 Setting for Unidirectional transmission mode**

**Table 4 Common setting of Master/Slave mode for Unidirectional transmission mode**

Use case		U-1	U-2		
Setting	DATA WIDTH	0	1		
	Downstream bit count	22	35		
	Upstream bit count	0	0		
Mode	CML line data rate	External reference clock mode: 1/tTCIP x 30	External reference clock mode: 1/tTCIP x 50		
		Internal oscillator clock mode: 1/tOSC x 30	Internal oscillator clock mode: 1/tOSC x 50		
Data pin for Master mode	D0/D34	=>	=>	D34/D0	Data pin for Slave mode
	D21/D13	-	=>	D13/D21	
	D22/D12	-	=>	D12/D22	
	D34/D0	-	=>	D0/D34	

"=>" means Downstream (GPIO input in Master mode and GPIO output in Slave mode). Start communication after setting each "Use case" in both Master/Slave.



**7.5. IO configuration**

**7.5.1. Input and Output digital noise filter**

THCS251 has digital noise filters for GPIO input (for CMOS input noise immunity) and output (for CML Line noise immunity) which are configured by setting FILTSEL1 and FILTSEL0 shown in Table 5 and Table 6. The data width less than (tap\_num - 1) tFLTCK is filtered. tap\_num is shown in Table 5 and Table 6.

**Table 5 Input digital noise filter setting**

FILTSEL1	FILTSEL0	Function	Filter number of taps (tap_num)
0	0	All digital noise filter setting	Disable
	1		4
1	0		8
	1		16

**Table 6 Output digital noise filter setting**

FILTSEL1	FILTSEL0	Function	Filter number of taps (tap_num)
0	0	All digital noise filter setting	Disable
	1		4
1	0		8
	1		16

**7.5.2. LVCMOS output buffer type configuration**

GPIO output buffer types are selectable from open-drain or push-pull by setting OBUF.

**Table 7 Output buffer type configuration**

Setting OBUF	Function
0	All GPIO outputs buffer type are selected to open-drain.
1	All GPIO outputs buffer type are selected to push-pull.

**7.5.3. 5V Tolerant I/O**

Figure 12 shows the 5V tolerant I/O. Master and Slave has eight 5V tolerant I/O each.

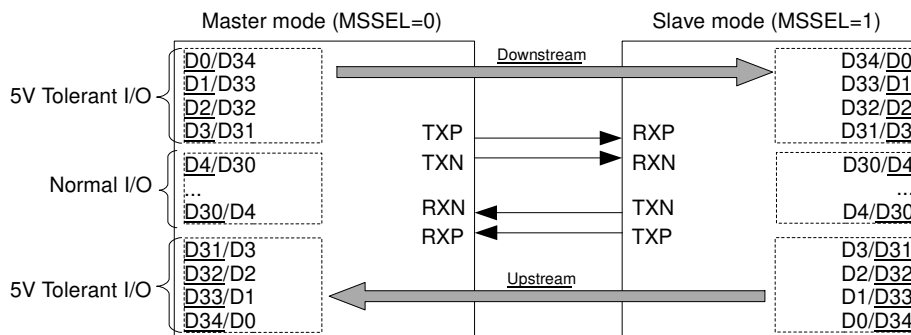

**Figure 12 5V tolerant I/O**

**7.6. Sampling clock configuration**

**7.6.1. Sampling clock selection**

GPIO sampling clock is always supplied from the Master mode and Master mode is selectable from internal oscillator clock or external reference clock input as shown in Figure 13, Table 8 and Table 9. Internal oscillator frequency is selectable from 20MHz, 40MHz or 80MHz.

Table 10 shows internal oscillator frequency and CML Line data rate. REFEN of Master mode and Slave mode shall be the same setting. GPIO data sampling clock of Slave mode is CDR clock from Rx.

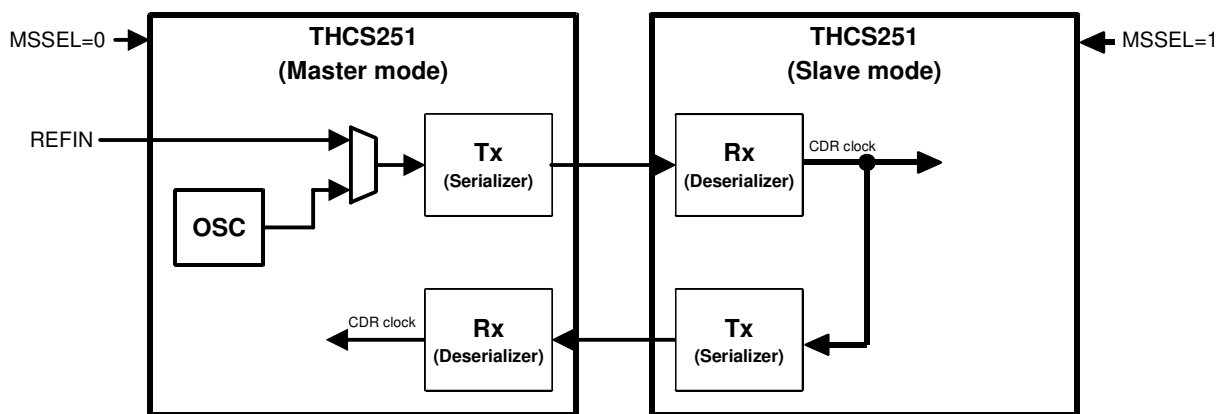

**Figure 13 GPIO sampling clock source**

**Table 9 Sampling clock and REFEN/REFOUT/OSCSEL1 and RF/OSCSEL0 function**

Setting		Sampling clock	REFEN/REFOUT/OSCSEL1	RF/OSCSEL0	Description
REFEN	MSSEL				
0	0 (Master mode)	Internal oscillator clock	Internal oscillator clock setting OSCSEL1, OSCSEL0		GPIO inputs are sampled by internal oscillator clock. Internal oscillator clock frequency is selected by setting of OSCSEL1 and OSCSEL0 (See Table 10)
	1 (Slave mode)	CDR clock	Hi-Z	- (Set to Low)	-
1	0 (Master mode)	External reference clock	External reference clock input REFEN	Sampling clock edge selection RF	GPIO inputs are sampled by external reference clock
	1 (Slave mode)	CDR clock	CDR clock output REFOUT	GPIO output clock edge selection RF	CDR clock output

**Table 10 Oscillator Clock Frequency and CML Line data rate**

Setting				Sampling frequency [*1]	CML Line data rate[*1]		Description
REFEN	MSSEL	OSCSEL1	OSCSEL0		DATA_WIDTH=0	DATA_WIDTH=1	
0	0 (Master mode)	0	0	20MHz	600Mbps	1Gbps	-
		0	1	-	-	-	Prohibition
		1	0	40MHz	1.2Gbps	2.0Gbps	-
		1	1	80MHz	2.4Gbps	Prohibition	-

\*1 Typical value, Spec is typical±20%

When REFEN=1, RF selects REFIN sampling clock edge of Master mode and REFOUT output clock edge of Slave mode.

**Table 11 RF Function**

Setting RF	Description	
	REFIN sampling edge	REFOUT output edge
0	Fall edge	Fall edge
1	Rise edge	Rise edge

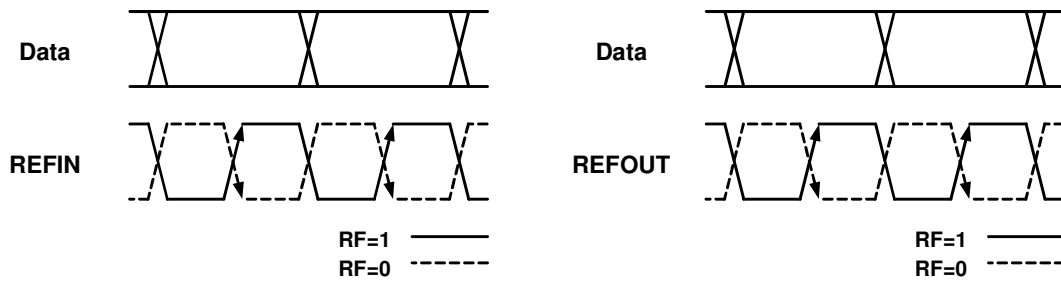

**Figure 14 Input / Output clock edge**

**7.6.2. Spread Spectrum Clock Generator (SSCG) and REFIN frequency**

THCS251 CML serial data output, GPIO data output and clock output are modulated by integrated SSCG. Only Master mode operates SSCG function. The SSCG is enabled by setting SSEN. When SSCG is enabled and operated with an external REF clock, RESET should be released after the input clock has stabilized.

**Table 12 SSCG setting registers**

Setting	Description
SSEN	
0	SSCG is off.
1	SSCG is on and fixed setting. Modulation rate is ±0.5%. Modulation frequency is 12kHz when fCLKSSCG = FREF = 20MHz. ( 20MHz / 1664 ) = 12kHz )

**Table 13 fCLKSSCG**

Setting			Sampling clock	Sampling clock frequency	fCLKSSCG
REFEN	OSCSEL1	OSCSEL0			
0	0	0	Internal oscillator clock	Low	FREF <sup>(*)</sup>
	0	1		-	-
	1	0		Low	FREF <sup>(*)</sup>
	1	1		High	FREF <sup>(*)</sup> /2
1	-		External reference clock input REFIN	15 – 57MHz	FREF <sup>(*)</sup>

\*1 FREF : Sampling clock frequency

**Table 14 External reference clock input frequency range and SSCG setting**

Setting		External reference clock input frequency range [MHz]	CML Line multiply ratio	CML Line data rate [Gbps]	SSCG
DATA_WIDTH	SSEN				
0	0	15 - 100	x30	0.45- 3.0	Disable
	1	15 - 57	x30	0.45 - 1.71	Enable
1	0	9 - 80	x50	0.45 - 4.0	Disable
	1	9 - 32.5	x50	0.45 - 1.625	Enable

### 7.7. Error detection and indication

THCS251 has READY and INT for indicating Link status of CML Line communication.

READY indicates establishment of communication for GPIOs. INT indicates CML Link communication error.

**Table 15 READY and INT**

Status		Description
READY	INT [*1]	
0	1 (pull-up)	CML Link communication unlock state GPIO cannot transmit
1	0	CML Link communication lock state Bit level error occurred
	1 (pull-up)	CML Link communication lock state No error

\*1 INT buffer type is open-drain. "1" output means pull-up.

**7.8. Standby mode**

THCS251 operates in Standby mode by setting STANDBY=1. The Standby mode is low power consumption and low frequency sampling rate transmission mode. In Standby mode, THCS251 can transmit up to 8-bits GPIO through handshake communication between Master mode and Slave mode. Polling period is 100ms. READY is also enabled in Standby mode. When handshake communication is completed, READY goes from low to high.

The GPIO pins shown in Table 16 are configured to Downstream, Upstream or Static state. On the other hand D4/D30 - D30/D4 are fixed to Static state as Hi-Z.

**Table 16 Standby mode direction setting**

Data Pin for Master mode	D0/D34	=>	D34/D0	Data Pin for Slave mode
	D1/D33	=>	D33/D1	
	D2/D32	=>	D32/D2	
	D3/D31	=>	D31/D3	
	D4/D30 - D30/D4	Static	D30/D4 - D4/D30	
	D31/D3	<=	D3/D31	
	D32/D2	<=	D2/D32	
	D33/D1	<=	D1/D33	
	D34/D0	<=	D0/D34	

“=>” means Downstream (GPIO input in Master mode and GPIO output in Slave mode).  
 “<=” means Upstream (GPIO input in Slave mode and GPIO output in Master mode).  
 “Static” means GPIO pins are Static state.

8. Package

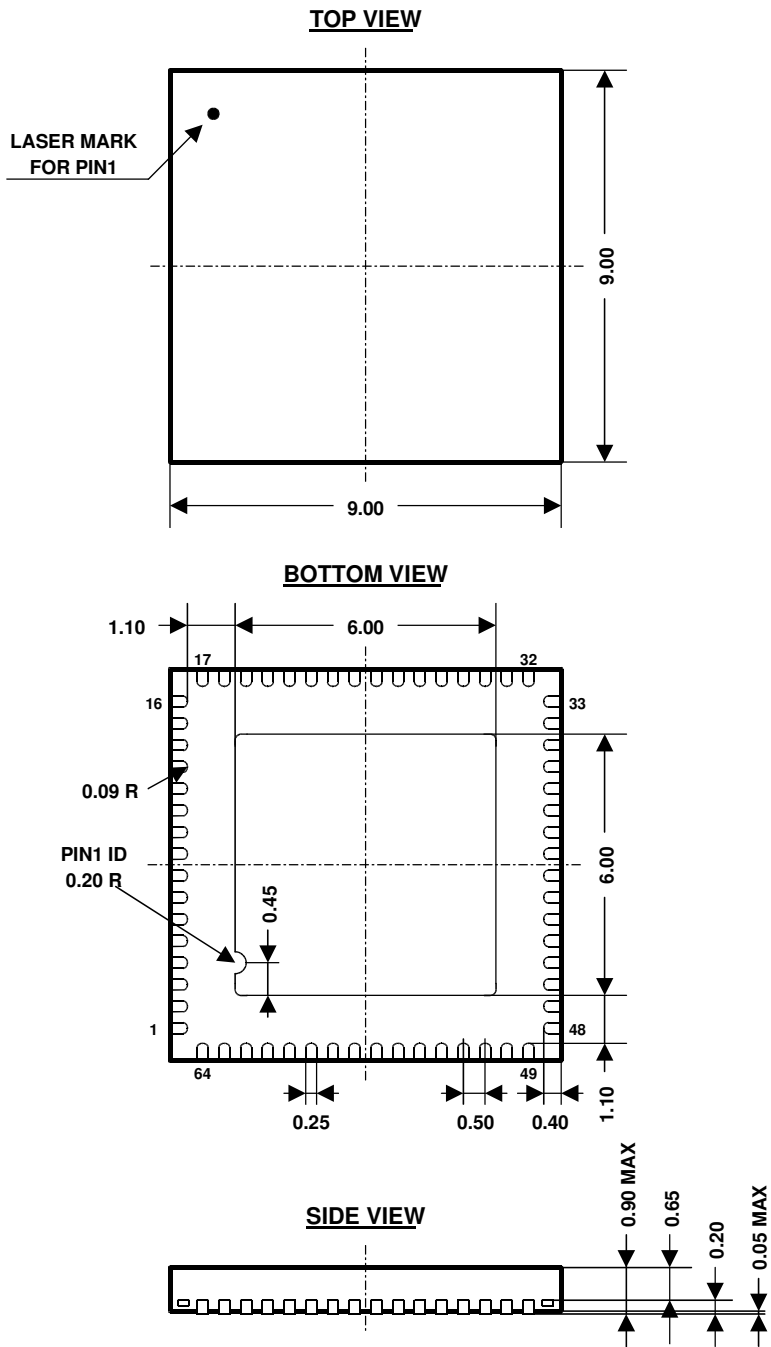

Figure 15 64-pin QFN package physical dimension

Unit : mm

---

### **Notices and Requests**

1. The product specifications described in this material are subject to change without prior notice.
2. The circuit diagrams described in this material are examples of the application which may not always apply to the customer's design. THine Electronics, Inc. ("THine") is not responsible for possible errors and omissions in this material. Please note even if errors or omissions should be found in this material, THine may not be able to correct them immediately.
3. This material contains THine's copyright, know-how or other intellectual property rights. Copying, reverse-engineering or disclosing to third parties the contents of this material without THine's prior written permission is prohibited.
4. Note that even if infringement of any third party's intellectual property rights should occur by using this product, THine will be exempted from the responsibility unless it directly relates to the production process or functions of the product.
5. This product is not designed for applications that require extremely high-reliability/safety such as aerospace device, nuclear power control device, or medical device related to critical care, excluding when this product is specified for automotive use by THine and used it for that purpose. THine accepts no liability whatsoever for any damages, claims or losses arising out of the uses set forth above.
6. Despite our utmost efforts to improve the quality and reliability of the product, faults will occur with a certain small probability, which is inevitable to a semi-conductor product. Therefore, you are encouraged to have sufficiently fail-safe design principles such as redundant or error preventive design applied to the use of the product so as not to have our product cause any social or public damage.
7. This product may be permanently damaged and suffer from performance degradation or loss of mechanical functionality if subjected to electrostatic charge exceeding capacity of the ESD (Electrostatic Discharge) protection circuitry. Safety earth ground must be provided to anything in contact with the product, including any operator, floor, tester and soldering iron.
8. Please note that this product is not designed to be radiation-proof.
9. Testing and other quality control techniques are used to this product to the extent THine deems necessary to support warranty for performance of this product. Except where mandated by applicable law or deemed necessary by THine based on the user's request, testing of all functions and performance of the product is not necessarily performed.
10. Customers are asked, if required, to judge by themselves if this product falls under the category of strategic goods under the Foreign Exchange and Foreign Trade Act in Japan and the Export Administration Regulations in the United States of America on export or transit of this product. This product is prohibited for the purpose of developing military modernization, including the development of weapons of mass destruction (WMD), and the purpose of violating human rights.
11. The product or peripheral parts may be damaged by a surge in voltage over the absolute maximum ratings or malfunction, if pins of the product are shorted by such as foreign substance. The damages may cause a smoking and ignition. Therefore, you are encouraged to implement safety measures by adding protection devices, such as fuses. THine accepts no liability whatsoever for any damage or loss caused to the user due to use under a condition exceeding the limiting values.



12. All patents or pending patent applications, trademarks, copyrights, layout-design exploitation rights or other intellectual property rights concerned with this product belong to THine or licensor(s) of THine. No license or right is granted to the user for any intellectual property right or other proprietary right now or in the future owned by THine or THine's licensor. The user must enter into a license agreement with THine or THine's licensor to be granted of such license or right.

***THine Electronics, Inc.***

<https://www.thine.co.jp>