



Model Description

FPD — 10 12 A3 — S B
 ① ② ③ ④ ⑤ ⑥

- ① Base model
- ② External diameter
- ③ Stroke
- ④ Symbol indicating characteristics
A3: Medium-load specifications
- ⑤ Symbol indicating form
S: S type (Standard)
- * Please refer to the external dimensions
- ⑥ Color symbol B: Black

SPECIFICATIONS

Model	Load (kg)	Max Absorption Energy J(kgf·m)	Speed Range (m/s)	Stroke mm
FPD-1012A3-SB	3	0.8(0.08)	0.5 or lower	12

Extension Force N(kgf)	Mass g	Main Unit Material	Operating Temp. C°	Cylinder Cap Color
3(0.3) or less	4.5	Resin	5~40	Black

IMPACT RATE AND MASS

FPD-1012A3

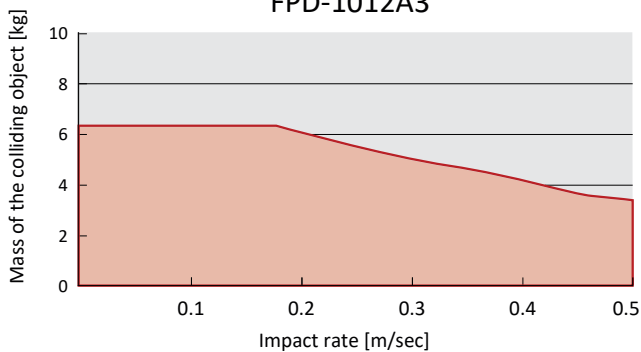

CHARACTERISTICS GRAPH

Changes in Operating Time for Each Load

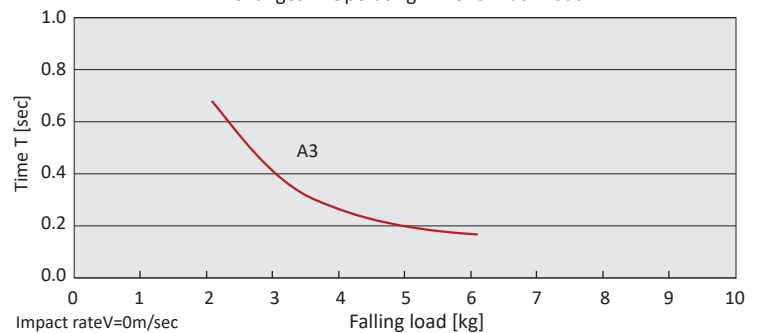

OPTIONAL PARTS

OP-200-01B/W S/C/R type

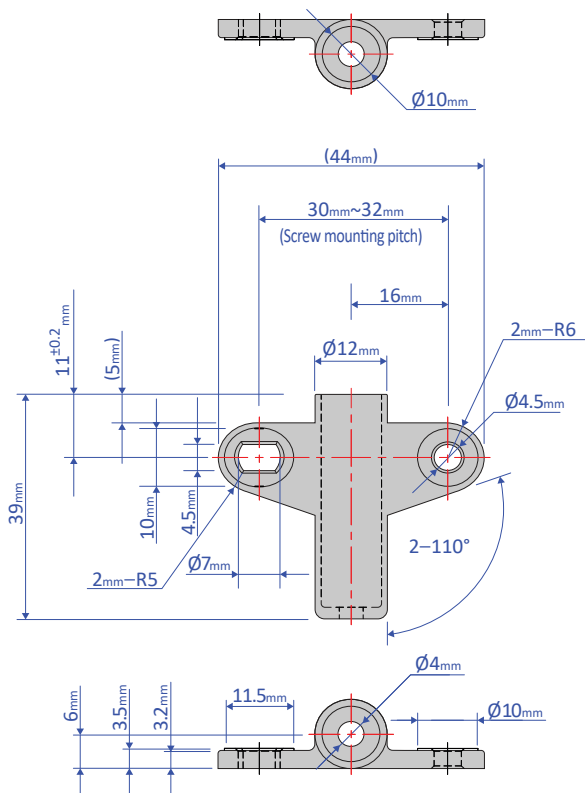

Screw: M4 (Truss screw)
Recommended tightening torque : 0.5N·m

OP-200-03B/W S/C/R/D type

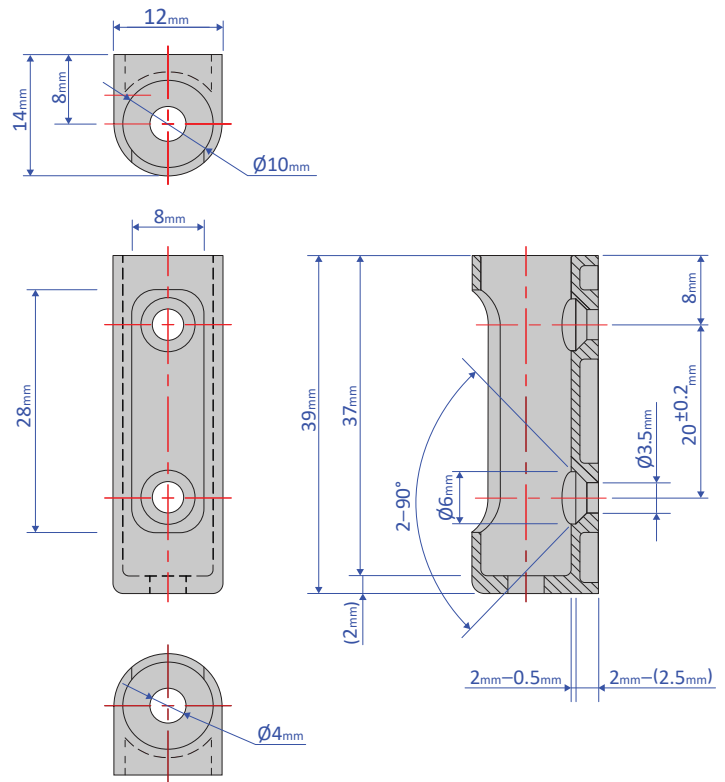

Screw: M3 (Flat head screw)
Recommended tightening torque : 0.3N·m

- These adaptors are dedicated for FPD-1012A series ■ They make it easy to install absorbers
- There are 2 colors: white and black ■ Material : Polyacetal (POM)

PRECAUTIONS FOR USE

- Do not use this product without carefully reading the attached owner's manual.
- Use with an external stopper.
- Ensure that sufficient mounting strength is secured for this product.
- 2 or more of this product can be used in parallel.
- Do not use this product in a vacuum or a location where it may come in contact with oil.
- Ensure that an eccentric load is not applied to the soft absorber.
 - S/C/R type ... Allowable eccentric angle: $\pm 2.5^\circ$ or less
 - D type Allowable eccentric angle: $\pm 6^\circ$ or less
- Do not pull the piston rod of the soft absorber. (This will cause air to get inside the soft absorber, causing ineffective stroke, abnormal sounds, and other damage to the soft absorber.)
- The difference between the speed of stroke and return of piston rod might influence the durability of the damper. So, please confirm sufficient performance on actual machine before use.

