

FEMALE STRAIGHT PLUG SOLDER TYPE

R222.051.000

CABLE .047

Series : SMP

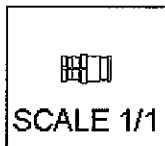
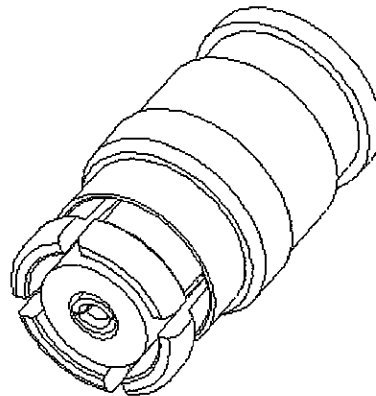
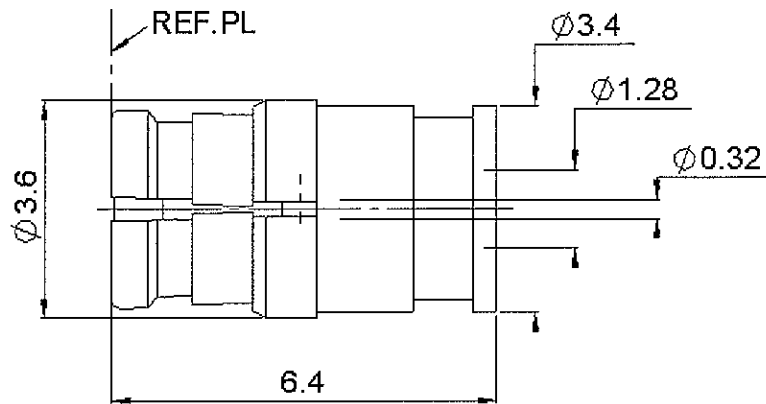

All dimensions are in mm.

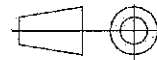

COMPONENTS	MATERIALS	PLATINGS (µm)
BODY	BERYLLIUM COPPER	GOLD 1.3 OVER NICKEL 2
CENTER CONTACT	BERYLLIUM COPPER	GOLD 1.27 OVER NICKEL 1.27
OUTER CONTACT	-	-
INSULATOR	PTFE	-
GASKET	-	-
OTHERS PARTS	BERYLLIUM COPPER	GOLD 1.3 OVER NICKEL 2
-	-	-
-	-	-

Issue : 0606 C

In the effort to improve our products, we reserve the right to make changes judged to be necessary.



FEMALE STRAIGHT PLUG SOLDER TYPE

R222.051.000

CABLE .047

Series : SMP

PACKAGING

Standard	Unit	Other
100	'W' option	Contact us

SPECIFICATION

CABLE ASSEMBLY

ELECTRICAL CHARACTERISTICS

Impedance		50 Ω
Frequency		0-40 GHz
VSWR	1.35 +	0 x F(GHz) Maxi
Insertion loss		0.12 √F(GHz) dB Maxi
RF leakage	- (- F(GHz)) dB mini
Voltage rating		335 Veff Maxi
Dielectric withstanding voltage		500 Veff mini
Insulation resistance		5000 MΩ mini

Stripping	a	b	c	d	e	f
mm	1.3	0	0	0	0	0

Assembly instruction :

Recommended cable(s)
UT47 M17/151-00001

Cable retention

- pull off 45 N mini
- torque NA N.cm

MECHANICAL CHARACTERISTICS

Center contact retention		
Axial force – Mating end	NA	N mini
Axial force – Opposite end	NA	N mini
Torque	NA	N.cm mini
Recommended torque		
Mating	NA	N.cm
Panel nut	NA	N.cm
Clamp nut	NA	N.cm
A/F clamp nut	0	mm
Mating life	100	Cycles mini
Weight	0.29	g

TOOLING

Part Number	Description	Hexagon
R282.740.030	SOLDERING MOUNTING	
R282.743.120	POSITIONER FOR SOLDERING SMP	
R282.744.253	POSITIONER FOR SOLDERING SMP	
R282.862.050	SOLDER GAUGE THCK .012	

ENVIRONMENTAL

Operating temperature	-65/+165 °C
Hermetic seal	NA Atm.cm3/s
Panel leakage	NA

OTHERS CHARACTERISTICS

RF leakage : -80dB DC-3GHz
-65dB 3-26.5GHz
Compliant with MIL-STD-348

Issue : 0606 C

In the effort to improve our products, we reserve the right to make changes judged to be necessary.



RADIALL®

FEMALE STRAIGHT PLUG SOLDER TYPE

R222.051.000

CABLE .047

Series : SMP

COMPONENTS

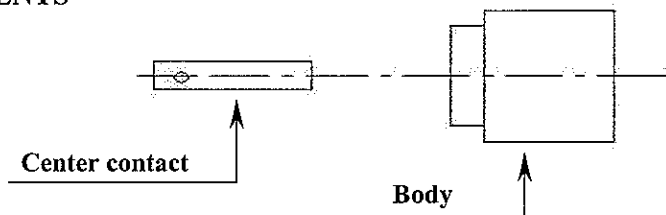

STRIPPING DIMENSIONS

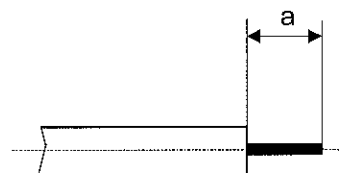

We recommend a thermal preconditioning cable

1

Strip the dielectric of the cable .
Trim the cable cone.
Clean the cable .
The iron temperature shall not exceeded 250°c

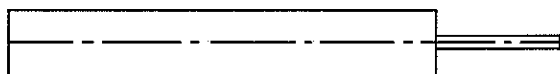

2

Screw the positioner onto the soldering jig.
Slide the center contact into positioner.
Insert the solder gauge between contact and the cable .
Tighten and solder the center contact.

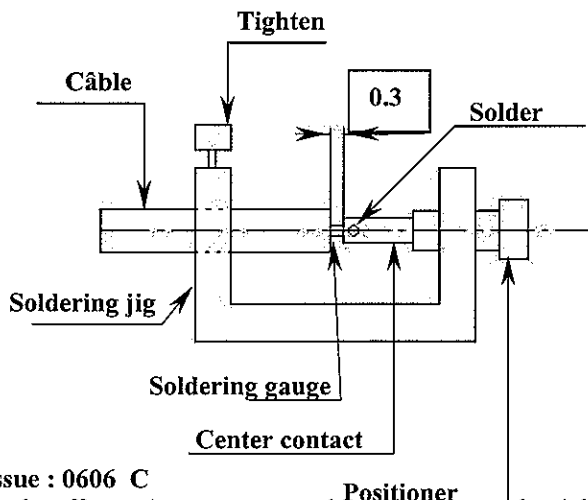

3

After cooling remove cable assembly from the jig.
Slide body into the positioner .
Slide cable into the connector until it bottoms against the positioner .
Tighten.
Solder the body onto the cable.
After cooling remove cable assembly from the jig.

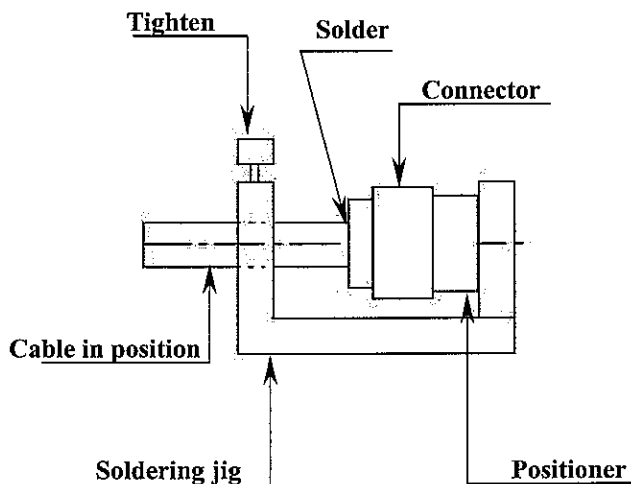

Issue : 0606 C

In the effort to improve our products, we reserve the right to make changes judged to be necessary.

