



# DIN signal male connector with special contacts



### General information

Design	IEC 60603-2		types: M invers male
No. of contacts (signal+special)	78+2, 60+4, 42+6, 24+8, 6+10		
Contact spacing	2,54 mm for signal contacts	7,62 mm for special contacts	
Test voltage	1000V		
Contact resistance	max. 20mOhm for crimp termination max. 15mOhm for wire wrap		
Insulation resistance	min. 10 <sup>10</sup> Ohm		
Working current	2A at 20°C (see derating diagram) for signal contacts for special contacts refer to corresponding data sheet		
Temperature range	-55°C ... +125°C -40°C ... +105°C for press-in connectors (due to limitations of PCB material)		
Termination technology	solder pins, press-in, wirewrap		
Clearance & creepage distance	min. 1,2mm		
Insertion and withdrawal force without special contacts	6pole max. 6N 24pole max. 23N	42pole max. 40N 60pole max. 57N	78pole max. 74N
Mating cycles	acc. to performance level, see table below		
UL file	E102079		
RoHS - compliant	Yes		
Leadfree	Yes		
Hot plugging	No		

### Insulator material

Material	PBT (thermoplastics, glass fiber reinforcement 30%)
Color	RAL 7032 (grey)
UL classification	UL 94-V0
Material group acc. IEC 60664-1	IIIa (175 ≤ CTI < 400)
NFF classification	I3, F4

### Contact material

Contact material	Copper alloy
Plating termination zone signal contacts	Sn over Ni for solder, Ni for press-in, Ni for wirewrap
Plating contact zone signal contacts	acc. to performance level, see table below
Plating special contacts	refer to corresponding data sheet

performance level	mating cycles		plating contact zone signal contacts
	acc. to IEC 60603-2	complementary acc. to IEC 60603-2	
1	500		<i>Au over PdNi over Ni</i>
2	400		<i>Au over PdNi over Ni</i>
3	50		<i>Au over PdNi over Ni</i>
NM30 (S4)		500	min. 0,76µm (30µinch) noble metal (alloy) over Ni

Standard plating options highlighted in *italic*, other plating options are available on request.

### Recommended configuration of plated through holes for press-in termination

In addition to the hot-air-level (HAL), other PCB surfaces are getting more important. Due to their different properties - such as mechanical strength and coefficient of friction - we recommend the following configuration of PCB through holes.

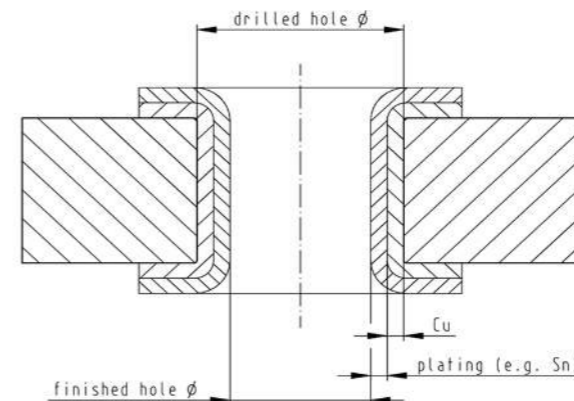

Tin plated PCB (HAL) acc. to EN 60352-5	Drilled hole Ø	1,15±0,025mm
	Cu	min. 25 µm
	Sn	max. 15µm
Chemical tin plated PCB	Drilled hole Ø	1,15±0,025 mm
	Cu	min. 25 µm
	Sn	min. 0,8 µm
Gold /Nickel plated PCB	Drilled hole Ø	1,15±0,025 mm
	Cu	min. 25 µm
	Ni	3-7 µm
Silver plated PCB	Drilled hole Ø	1,15±0,025 mm
	Cu	min. 25 µm
	Ag	0,1 - 0,3 µm
Copper plated PCB (OSP)	Drilled hole Ø	1,15±0,025 mm
	Cu	min. 25 µm
	plated hole Ø	1,00 - 1,10 mm

### Assembly instructions

It is highly recommended to use HARTING press-in tools to ensure a reliable press-in process. Please refer to the catalogue for tools, machines and further information about the press-in process.

### Soldering instructions

The connectors should be protected when being soldered in a dip, flow or film soldering baths. Otherwise, they might become contaminated as a result of soldering operations or deformed as a result of overheating.

(1) For prototypes and short runs protect the connectors with an industrial adhesive tape, e.g. Tesaband 4331 (www.tesa.de). Cover the underside of the connector moulding and the adjacent parts of the pcb as well as the open sides of the connector. This will prevent heat and gases of the soldering apparatus from damaging the connector. About 140 + 5 mm of the tape should suffice.

(2) For large series a jig is recommended. Its protective cover with a fast action mechanical locking device shields the connectors from gas and heat generated by the soldering apparatus. As an additional protection a foil can be used for covering the parts that should not be soldered.

### Cross section of solder terminations

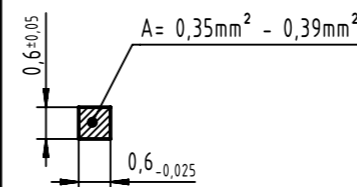

### Derating diagram acc. to IEC 60512-5 (Current carrying capacity)

The current carrying capacity is limited by maximum temperature of materials for inserts and contacts including terminals.

The current capacity curve is valid for continuous, non interrupted current loaded contacts of connectors when simultaneous power on all contacts is given, without exceeding the maximum temperature.

Control and test procedures according to DIN IEC 60512-5

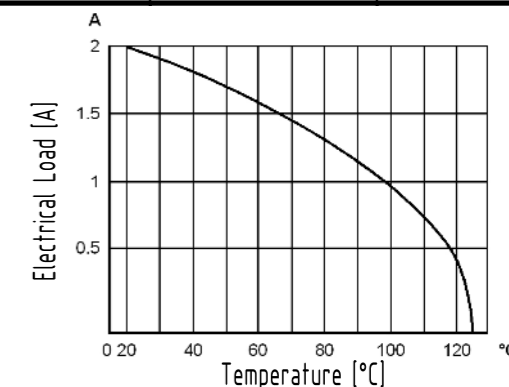

	All Dimensions in mm Original Size DIN A3	Scale 1:1	Free size tol.	Ref.
				Sub.
	All rights reserved Department EL PD	Created by STORCK	Inspected by LEHNERT	Standardisation 302077
				Date 2020-10-14
HARTING Electronics GmbH D-32339 Espelkamp	Title DIN signal male connector with special contacts			Doc-Key / ECM-Nr. 100580759/UGD/000/B 500000180986
	Type DS	Number 09731100002	Rev. B	Page 1/1