

APPLICATIONS

- Power source for hand-held equipment
- Power source for LCD and CCD

SELECTION GUIDE

The UVLO threshold voltage is user-selectable.

Product Name	Package	Quantity per Reel	Pb Free	Halogen Free
R1294L10xA-E2	QFN0404-24B	1,000 pcs	Yes	Yes

x: Specify the UVLO threshold voltage

1: 1.8 V

2: 2.2 V

3: 2.8 V

BLOCK DIAGRAM

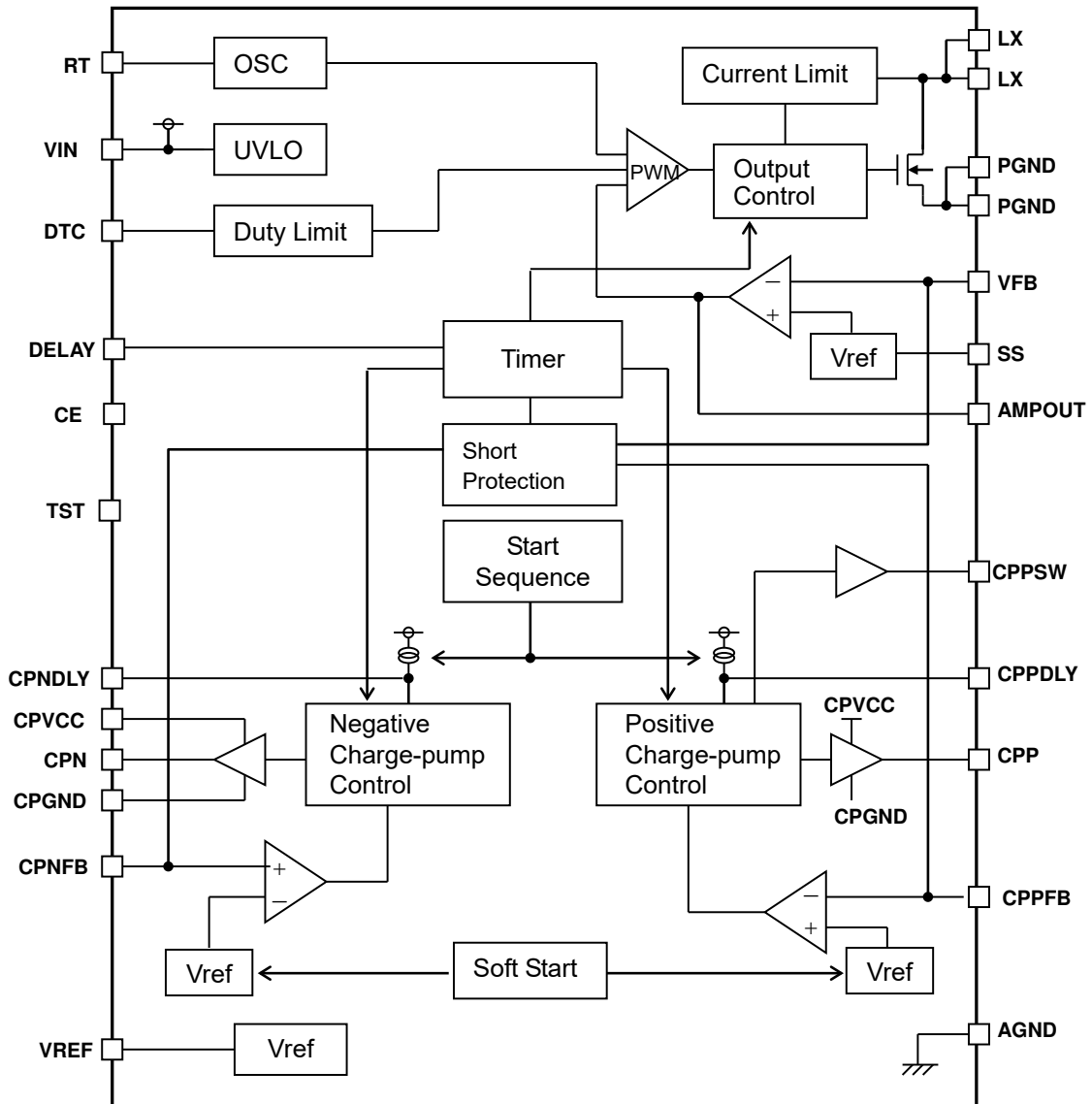

R1294L Block Diagram

PIN DESCRIPTIONS

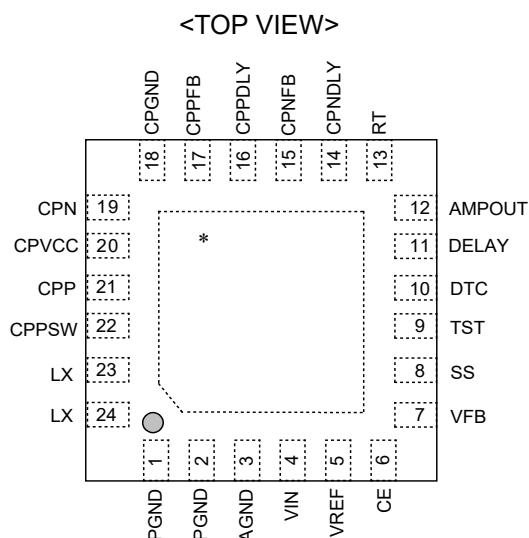

R1294L(QFN0404-24B) Pin Configuration

Pin No.	Symbol	Description
1	PGND	Power GND Pin
2	PGND	Power GND Pin
3	AGND	Analog GND Pin
4	VIN	Power Input Pin
5	VREF	Reference Voltage Output Pin
6	CE	Chip Enable Pin
7	VFB	Step-up DC/DC Feedback Pin
8	SS	Step-up DC/DC Soft-start Pin
9	TST	TEST Pin
10	DTC	Step-up DC/DC Maxduty Setting Pin
11	DELAY	Short Protection Delay Setting Pin
12	AMPOUT	Amplifier Output Pin For Phase Compensation
13	RT	Oscillator Frequency Setting Pin
14	CPNDLY	Negative Charge-pump Delay Setting Pin
15	CPNFB	Negative Charge-pump Feedback Pin
16	CPPDLY	Positive Charge-pump Delay Setting Pin
17	CPPFB	Positive Charge-pump Feedback Pin
18	CPGND	Charge-pump GND Pin
19	CPN	Negative Charge-pump Driver Output Pin
20	CPVCC	Power Pin for Charge-pump
21	CPP	Positive Charge-pump Driver Output Pin
22	CPPSW	Output Control Pin for Positive Charge-pump
23	LX	Step-up DC/DC Driver Output Pin
24	LX	Step-up DC/DC Driver Output Pin

* The tab on the bottom of the package enhances thermal performance and is electrically connected to GND (substrate level). It is recommended that the tab be connected to the ground plane on the board, or otherwise be left floating.

ABSOLUTE MAXMUM RATINGS

(GND = 0 V)

Symbol	Item	Ratings	Unit
V_{IN}	V_{IN} pin voltage	6.5	V
V_{DTC}	DTC pin voltage	-0.3 to $V_{IN} + 0.3$	V
V_{FB}	V_{FB} pin voltage	-0.3 to $V_{IN} + 0.3$	V
V_{SS}	SS pin voltage	-0.3 to $V_{IN} + 0.3$	V
V_{DELAY}	DELAY pin voltage	-0.3 to $V_{IN} + 0.3$	V
V_{AMP}	AMPOUT pin voltage	-0.3 to $V_{IN} + 0.3$	V
V_{LX}	L_x pin voltage	-0.3 to 24	V
I_{LX}	L_x pin current	Internally limited	A
V_{REF}	V_{REF} pin voltage	-0.3 to $V_{IN} + 0.3$	V
V_{CPVCC}	CPVCC pin voltage	-0.3 to 24	V
V_{CE}	CE pin voltage	-0.3 to $V_{IN} + 0.3$	V
V_{RT}	RT pin voltage	-0.3 to $V_{IN} + 0.3$	V
V_{CPPDLY}	CPPDLY pin voltage	-0.3 to $V_{IN} + 0.3$	V
V_{CPNDLY}	CPNDLY pin voltage	-0.3 to $V_{IN} + 0.3$	V
V_{PFEB}	CPPFB pin voltage	-0.3 to $V_{IN} + 0.3$	V
V_{NFEB}	CPNFB pin voltage	-0.3 to $V_{IN} + 0.3$	V
V_{CPP}	CPP pin voltage	-0.3 to 24	V
V_{CPN}	CPN pin voltage	-0.3 to 24	V
V_{PSW}	CPPSW pin voltage	-0.3 to 24	V
I_{PSW}	CPPSW pin current-A	20	mA
P_D	Power dissipation ⁽¹⁾ (QFN0404-24B, JEDEC STD. 51.7)	3400	mW
T_j	Junction Temperature	-40 to 125	°C
T_{stg}	Storage temperature range	-55 to 125	°C

ABSOLUTE MAXIMUM RATINGS

Electronic and mechanical stress momentarily exceeded absolute maximum ratings may cause the permanent damages and may degrade the lifetime and safety for both device and system using the device in the field. The functional operation at or over these absolute maximum ratings are not assured.

⁽¹⁾ Refer to *POWER DISSIPATION* in the APPENDIX for detailed information.

RECOMMENDED OPERATING CONDITIONS

Symbol	Item		Rating	Unit
V_{IN}	Input voltage	R1294L101A	2.0 to 5.5	V
		R1294L102A	2.5 to 5.5	V
		R1294L103A	3.3 to 5.5	V
CPVCC	CPVCC operating voltage		6 to 20	V
Ta	Operating temperature		-40 to 95	°C

RECOMMENDED OPERATING CONDITIONS

All of electronic equipment should be designed that the mounted semiconductor devices operate within the recommended operating conditions. The semiconductor devices cannot operate normally over the recommended operating conditions, even if when they are used over such conditions by momentary electronic noise or surge. And the semiconductor devices may receive serious damage when they continue to operate over the recommended operating conditions.

ELECTRICAL CHARACTERISTICS

V_{IN} is set as shown below for every version, unless otherwise noted.

R1294L101A: $V_{IN} = 2.5\text{ V}$

R1294L102A: $V_{IN} = 2.5\text{ V}$

R1294L103A: $V_{IN} = 3.5\text{ V}$

The specifications surrounded by are guaranteed by design engineering at $-40^{\circ}\text{C} \leq T_a \leq 95^{\circ}\text{C}$.

R1294L Electrical Characters

($T_a = 25^{\circ}\text{C}$)

Symbol	Item	Conditions	Min.	Typ.	Max.	Unit	
I_{IN}	V_{IN} Supply Current	$V_{IN} = 5.5\text{ V}$, $R_T = 24\text{ k}\Omega$		3.5		mA	
V_{UVLO1}	UVLO Detect Voltage V_{IN} Falling	R1294L101A	1.7	1.8	1.9	V	
		R1294L102A	2.05	2.2	2.35	V	
		R1294L103A	2.6	2.8	3.0	V	
V_{UVLO2}	UVLO Release Voltage V_{IN} Rising	R1294L101A		$V_{UVLO1} + 0.09$	2.0	V	
		R1294L102A		$V_{UVLO1} + 0.15$	2.5	V	
		R1294L103A		$V_{UVLO1} + 0.22$	3.2	V	
V_{FB}	V_{FB} Voltage		0.985	1.0	1.015	V	
$\Delta V_{FB}/\Delta T$	V_{FB} Voltage Temperature Coefficient	$-40^{\circ}\text{C} \leq T_a \leq 95^{\circ}\text{C}$		± 150		ppm/ $^{\circ}\text{C}$	
V_{FBL}	V_{FB} Fault Voltage			$V_{FB} \times 0.85$		V	
I_{FB}	V_{FB} Input Current	$V_{IN} = 5.5\text{ V}$, $V_{FB} = 0\text{ V}$ or 5.5 V	-0.1		0.1	μA	
V_{DTC0}	Duty = 0% DTC Voltage	$R_T = 24\text{ k}\Omega$	0.27	0.37	0.47	V	
V_{DTC20}	Duty = 20% DTC Voltage	$R_T = 24\text{ k}\Omega$		0.49		V	
V_{DTC80}	Duty = 80% DTC Voltage	$R_T = 24\text{ k}\Omega$		0.91		V	
Maxduty	Maximum Duty Limit	$R_T = 24\text{ k}\Omega$, $V_{DTC} = V_{IN}$	86	91	96	%	
I_{AMPH}	AMP "H" Output Current	$V_{FB} = 0.9\text{ V}$	R1294L101A/10 2A	1.6	3.2	5.8	mA
			R1294L103A	4.7		14.5	mA
I_{AMPL}	AMP "L" Output Current	$V_{FB} = 1.1\text{ V}$	40	80	120	μA	
R_{ON}	Switch ON Resistance			150		m Ω	
I_{LXOFF}	Leakage Current	$V_{IN} = 5.5\text{ V}$, $V_{LX} = 20\text{ V}$			5	μA	
I_{LIMDC}	Switch Limit Current		2.0			A	

V_{IN} is set as shown below for every version, unless otherwise noted.

R1294L101A: $V_{IN} = 2.5\text{ V}$

R1294L102A: $V_{IN} = 2.5\text{ V}$

R1294L103A: $V_{IN} = 3.5\text{ V}$

The specifications surrounded by are guaranteed by design engineering at $-40^{\circ}\text{C} \leq T_a \leq 95^{\circ}\text{C}$

R1294L Electrical Characters (Continued)

($T_a = 25^{\circ}\text{C}$)

Symbol	Item	Conditions	Min.	Typ.	Max.	Unit
f_{REQ}	Oscillator Frequency	RT = 110 k Ω	175	210	245	kHz
		RT = 24 k Ω	736	800	864	kHz
		RT = 12 k Ω	1300	1400	1500	kHz
V_{REF}	V_{REF} Voltage		1.182	1.2	1.218	V
$\Delta V_{REF}/\Delta T$	V_{REF} Voltage Temperature Coefficient			150		ppm/ $^{\circ}\text{C}$
I_{OUT}	V_{REF} Current		2.0			mA
$\Delta V_{REF}/\Delta V_{IN}$	V_{REF} Line Regulation	R1294L101A $V_{IN} = 2.0$ to 5.5 V		5	10	mV
		R1294L102A $V_{IN} = 2.5$ to 5.5 V				
		R1294L103A $V_{IN} = 3.3$ to 5.5 V				
$\Delta V_{REF}/\Delta I_{OUT}$	V_{REF} Load Regulation	$I_{OUT} = 0.1\text{ mA}$ to 2.0 mA		6	20	mV
I_{LIM}	Short Current Limit			15		mA
I_{CPVCC}	CPVCC Supply Current	CPVCC = 9 V, RT = 24 k Ω		500		μA
I_{SS}	Soft-Start Current	CPVCC = 9 V	2.5	5.0	7.5	μA
t_{PSS}	CPP Soft-Start Time	CPVCC = 9 V		4.0		ms
t_{NSS}	CPN Soft-Start Time	CPVCC = 9 V		4.0		ms
I_{PDLY}	CPPDLY Charge Current	CPVCC = 9 V	2.5	5.0	7.5	μA
I_{NDLY}	CPNDLY Charge Current	CPVCC = 9 V	2.5	5.0	7.5	μA
V_{PDLY}	CPPDLY Detector Threshold	CPVCC = 9 V	0.95	1.00	1.05	V
V_{NDLY}	CPNDLY Detector Threshold	CPVCC = 9 V	0.95	1.00	1.05	V
V_{PFB}	CPPFB Voltage	CPVCC = 9 V	1.475	1.500	1.525	V
$\Delta V_{PFB}/\Delta T$	CPPFB Voltage Temperature Coefficient	CPVCC = 9 V $-40^{\circ}\text{C} \leq T_a \leq 95^{\circ}\text{C}$		150		ppm/ $^{\circ}\text{C}$
V_{NFB}	CPNFB Voltage	CPVCC = 9 V	-0.03	0.00	0.03	V
V_{PFB}	CPPFB Fault Voltage	CPVCC = 9 V		$V_{PFB} \times 0.85$		V

V_{IN} is set as shown below for every version, unless otherwise noted.

R1294L101A: $V_{IN} = 2.5\text{ V}$

R1294L102A: $V_{IN} = 2.5\text{ V}$

R1294L103A: $V_{IN} = 3.5\text{ V}$

The specifications surrounded by are guaranteed by design engineering at $-40^{\circ}\text{C} \leq T_a \leq 95^{\circ}\text{C}$

R1294L Electrical Characters (Continued)

($T_a = 25^{\circ}\text{C}$)

Symbol	Item	Conditions	Min.	Typ.	Max.	Unit	
V_{NFBL}	CPNFB Fault Voltage	CPVCC = 9 V		0.15		V	
R_{CPPH}	CPP "H" ON Resistance	CPVCC = 9 V		5		Ω	
R_{CPPL}	CPP "L" ON Resistance	CPVCC = 9 V		10		Ω	
R_{CPNH}	CPN "H" ON Resistance	CPVCC = 9 V		5		Ω	
R_{CPNL}	CPN "L" ON Resistance	CPVCC = 9 V		10		Ω	
f_{REQCP}	Charge-pump Frequency	CPVCC = 9 V		$f_{REQ}/4$		kHz	
I_{DELAY1}	DELAY Charge Current	CPVCC = 9 V	2.5	5.0	7.5	μA	
I_{DELAY2}	DELAY Discharge Current	CPVCC = 9 V		200		μA	
V_{DELAY}	DELAY Detector Threshold	CPVCC = 9 V	0.95	1.0	1.05	V	
V_{PSW}	CPPSW "L" Output Voltage	CPVCC = 9 V, $I = 1\text{ mA}$		0.2		V	
$I_{standby1}$	Standby Current			0.1	5	μA	
$I_{standby2}$	CPVCC Standby Current			0.1	5	μA	
V_{CEL}	CE "L" Input Voltage	R1294L101A	$V_{IN} = 2.0\text{ V}$			0.3	V
		R1294L102A	$V_{IN} = 2.5\text{ V}$				
		R1294L103A	$V_{IN} = 3.3\text{ V}$				
V_{CEH}	CE "H" Input Voltage	$V_{IN} = 5.5\text{ V}$	1.5			V	

THEORY OF OPERATION

Overcurrent Protection

R1294L monitors the Nch-switch current of the step-up DCDC converter and limits the current. If Nch-switch current reaches the current limit, the R1294L immediately turns off Nch-switch. Nch-switch turns on every internal cycle, and the R1294L monitors Nch-switch current and turns off Nch-switch if Nch-switch current reaches the current limit again. By repeating this operation, the R1294L protects itself from the overcurrent.

Under Voltage Lock Out (UVLO)

If V_{IN} pin voltage becomes equal to or lower than UVLO detector threshold, the R1294L immediately disables all the switching outputs (L_x , CPP, and CPN) as well as discharges the external capacitors on DTC pin and SS pin down to 0 V immediately, and the system will be reset.

Operation and Output Current of Step-up DC/DC Converter

< Typical Circuit >

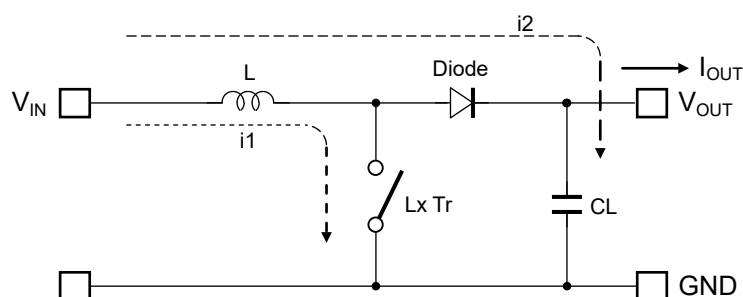

< Current through L >

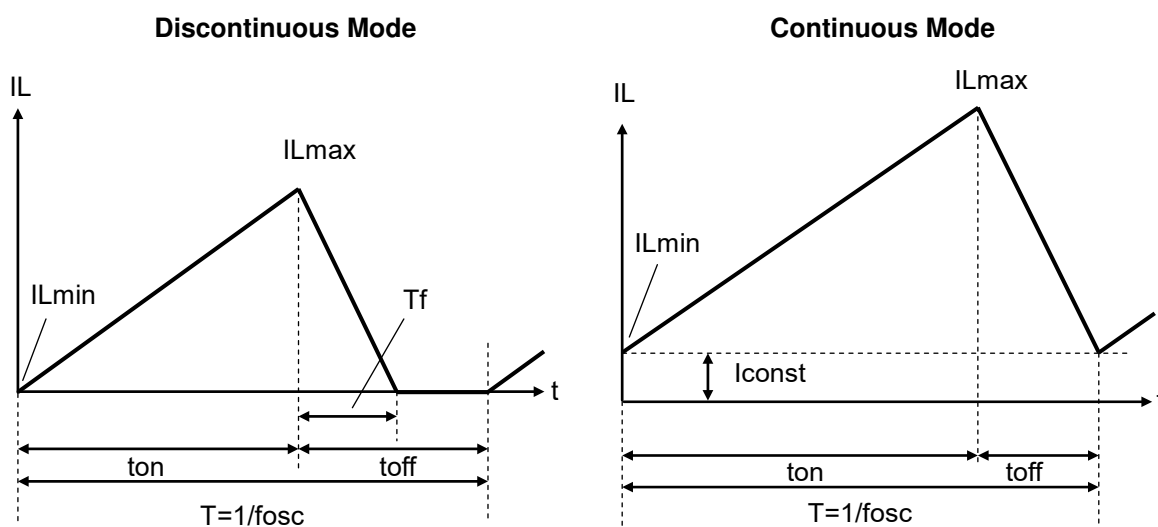

In PWM step-up DC/DC converter, there are two modes; the discontinuous mode and the continuous mode. These two modes depend upon the continuous characteristic of the inductor current.

While PWM step-up DC/DC converter is turned on, the voltage into the inductance L will be V_{IN} , and the additional current (i_1) can be calculated by the next formula.

$$\Delta i_1 = V_{IN} \times t_{on} / L$$

In the circuit of the step-up DC/DC converter, during the off time of the switching, the power is supplied. In this case, the decrease of input current (i_2) can be calculated by the next formula:

$$\Delta i_2 = (V_{OUT} - V_{IN}) \times T_f / L$$

In the PWM switching method, the current of inductor becomes continuous when it is $T_f = t_{off}$. The operating of DC/DC converter becomes continuous mode. In the continuous mode, the variance of the ratio of current is equal ($\Delta i_1 = \Delta i_2$), therefore the DUTY in the continuous mode is calculated by the next formula.

$$\text{duty (\%)} = t_{on} / (t_{on} + t_{off}) = (V_{OUT} - V_{IN}) / V_{OUT}$$

If the input power and the output power are equal, the mode becomes continuous when the I_{OUT} value is larger than the next formula.

$$V_{IN}^2 \times t_{on} / (2 \times L \times V_{OUT})$$

The average of the inductor current when $T_f = t_{off}$ is calculated by the next formula.

$$i_1 (\text{Ave.}) = V_{IN} \times t_{on} / (2 \times L)$$

The peak current (I_{Lxmax}) of the inductor in the continuous mode can be calculated by the next formula:

$$\begin{aligned} I_{Lxmax} &= I_{OUT} \times V_{OUT} / V_{IN} + V_{IN} \times t_{on} / (2 \times L) \\ I_{Lxmax} &= I_{OUT} \times V_{OUT} / V_{IN} + V_{IN} \times T \times (V_{OUT} - V_{IN}) / (2 \times L \times V_{OUT}) \end{aligned}$$

As stated above, the value of the peak current becomes larger than the I_{OUT} value, therefore note that the I_{Lxmax} to determine the I/O condition and the components around the I/O.

The actual maximum output current is 50 to 80% of the above-mentioned. Especially, in case that the I_L is large, or V_{IN} is low, the loss of V_{IN} will be the amount of the ON resistance of the switch. As for the V_{OUT} , it is necessary to consider the V_F of the diode (approximately 0.3 V).

Note: The above-mentioned explanation is based on the calculations of the ideal case. The external components or the loss of L_x switching are not included.

TIMING CHART

Overall Sequence

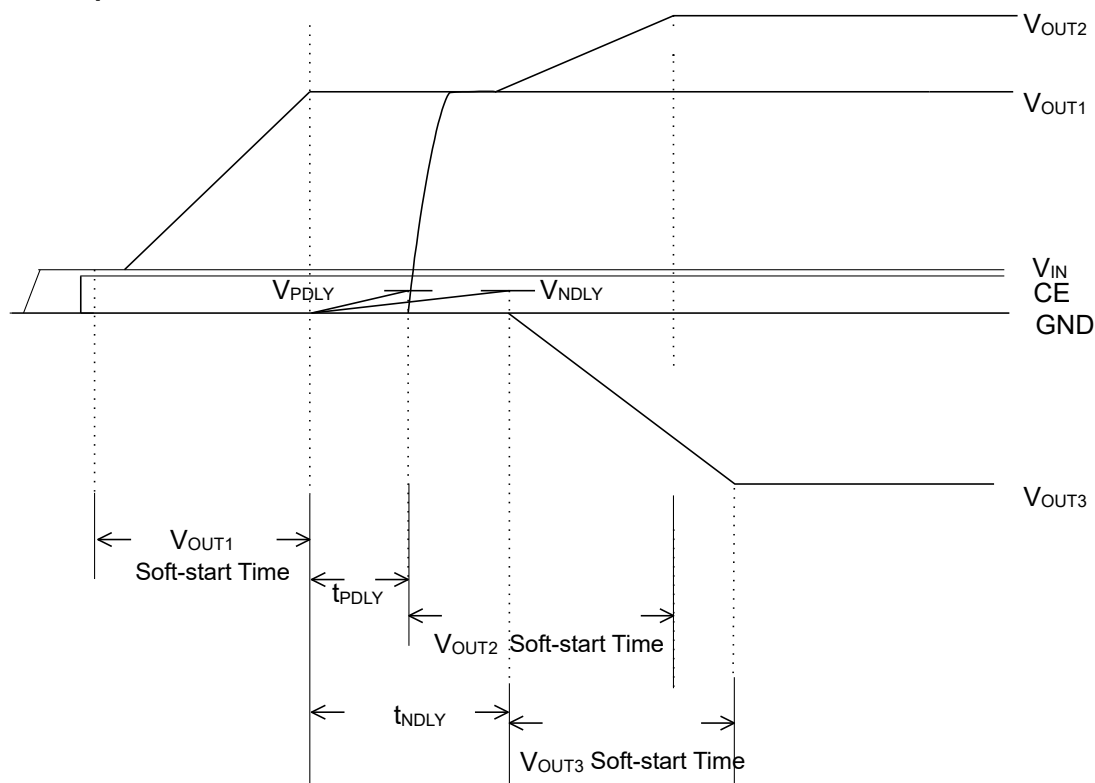

Overall Sequence Timing Chart

The timing chart above describes from the power on to the V_{OUT1} , V_{OUT2} , and V_{OUT3} turn on and until they are stable.

By releasing from the standby mode, V_{OUT1} begins the soft-start, and the output voltage rises gradually. After preset soft-start time passes, and the V_{OUT1} reaches the preset output voltage, the charge to capacitors set to CPPDLY pin and CPNDLY pin will start. CPPDLY pin and CPNDLY pin voltage reach respectively to the CPPDLY detector threshold (V_{PDLY}) and CPNDLY detector threshold (V_{NDLY}), then the soft-start of the charge-pump will begin. The delay time for soft-start of charge pump (t_{PDLY} , t_{NDLY}) can be set respectively.

When each delay time has passed, the soft-start of the charge-pump begins. V_{OUT2} and V_{OUT3} gradually turn on, and when the soft-start time ends, V_{OUT2} and V_{OUT3} reach the preset output voltage.

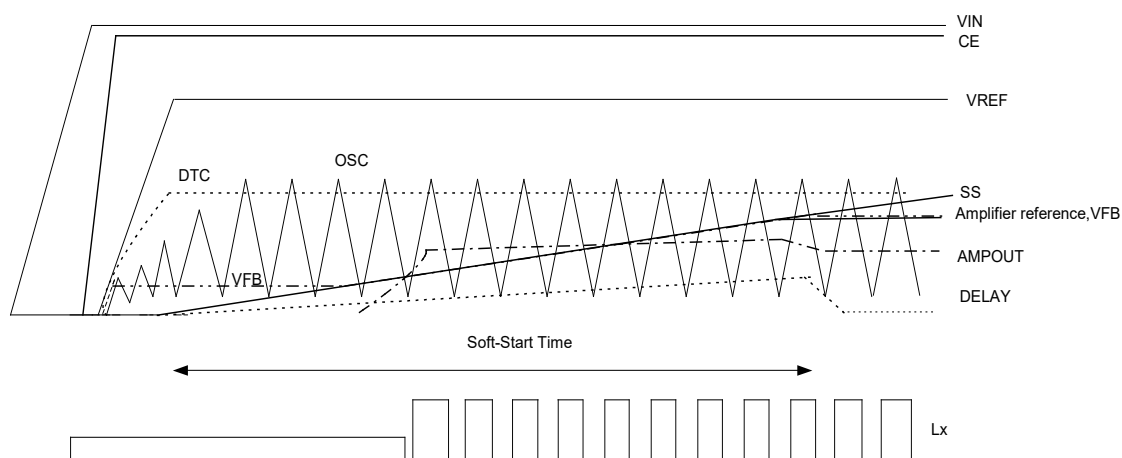
V_{OUT1} Soft-start Operation**V_{OUT1} Soft-start Timing Chart**

The timing chart above describes from the CE signal turns on until the soft-start of V_{OUT1} ends.

(STEP1)

SS voltage gradually increases with the internal IC's constant current and the external capacitor. During the soft-start time, the amplifier's reference input to the OP AMP becomes an equal voltage as SS, and it gradually increases. Since V_{OUT} reaches to the input voltage just after the power on, the VFB voltage rises at the specific voltage determined by the resistance ratio of the input voltage and the feedback part. However, the switching does not begin since AMPOUT is "L".

(STEP2)

When the SS becomes the specified voltage determined with the resistance ratio of the input voltage and the feedback part, the switching begins. In this case, the amplifier reference rises as well as SS, therefore V_{OUT} rises to balance the amplifier reference and VFB. The DUTY in this case is determined by the three inputs PWM comparator, among the AMPOUT and DTC, the lowest voltage is selected.

(STEP3)

When the SS becomes 1 V, the soft-start ends. After that, the amplifier reference becomes the constant voltage (= 1 V), and the operation changes to the normal switching. At this time, the voltage of the AMPOUT becomes constant. The AMPOUT value is determined by the I/O voltage and the output current.

During the soft-start period, the soft-start time needs to be set shorter than the timer latch delay time due to the charging of DELAY pin. When the preset soft-start time finishes, the charging of DELAY pin stops and discharges to the GND.

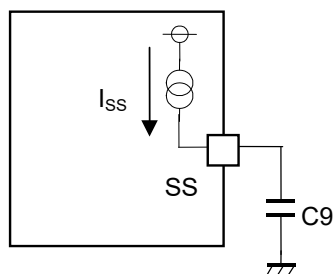

SS Pin

APPLICATION INFORMATION

TYPICAL APPLICATION

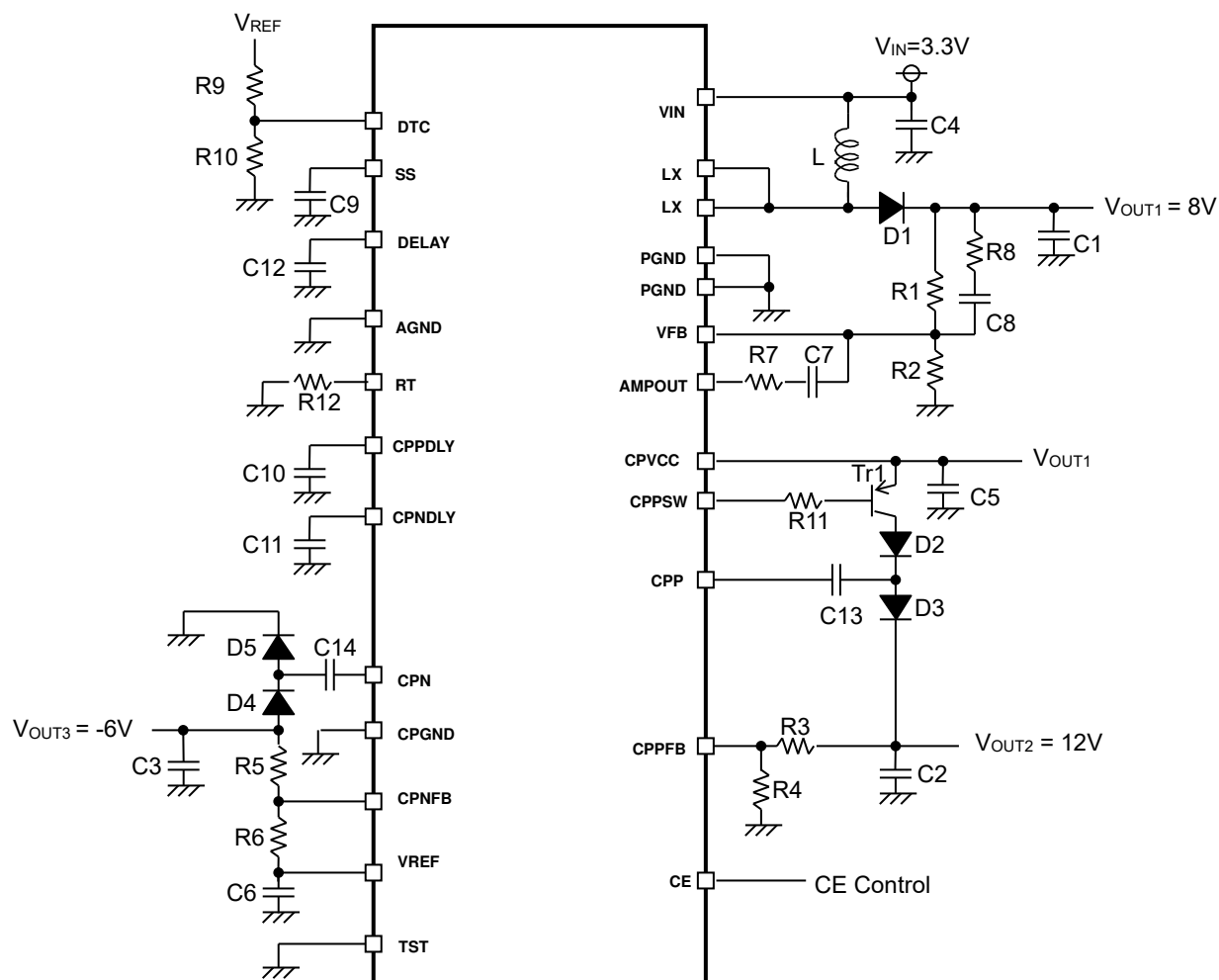

R1294L10xA Typical Application 1

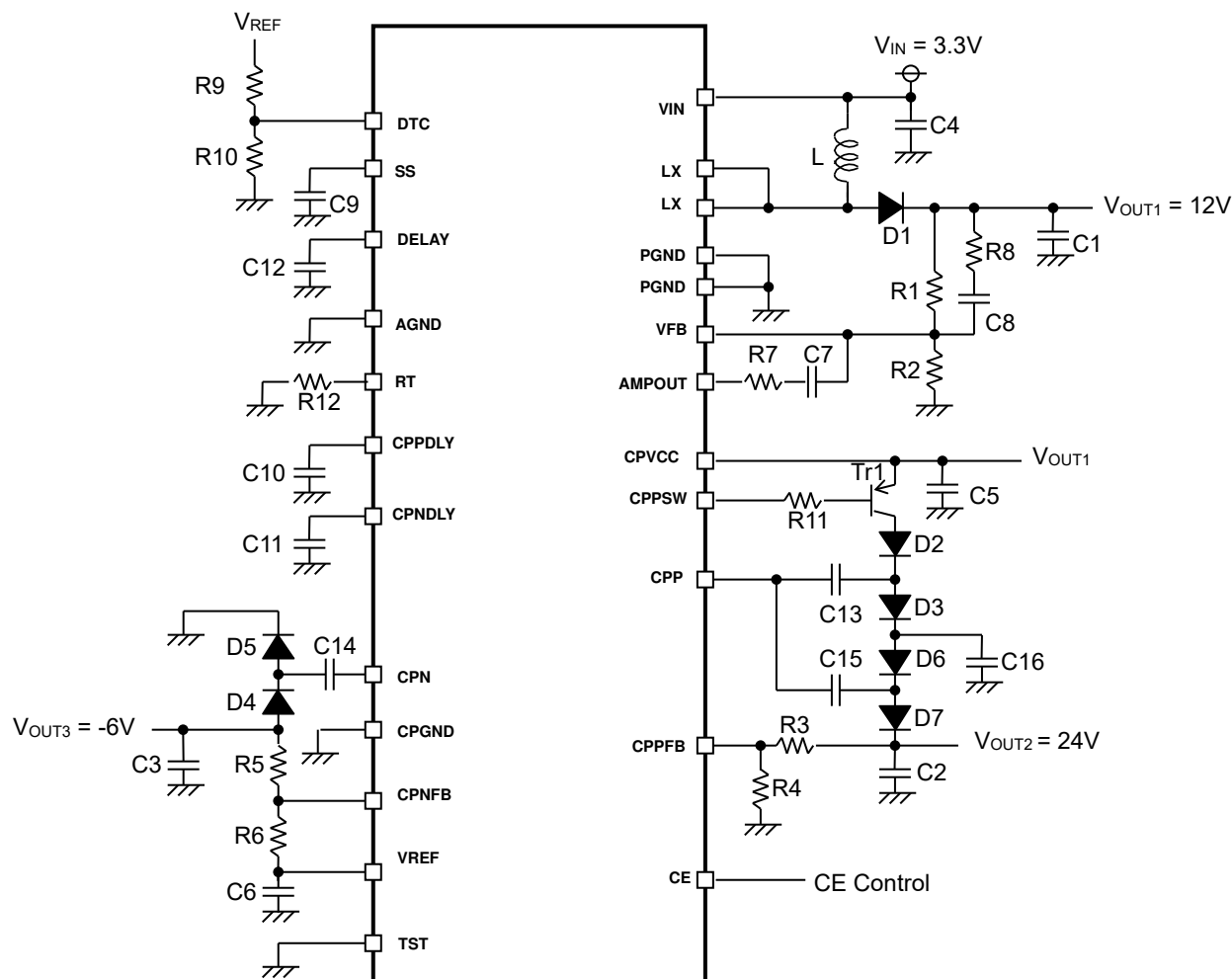

R1294L10xA Typical Application 2

Recommended External Components

Symbol	Description
L	NR4018T100M (for 210 kHz) / NR4018T4R7M (for 700 kHz) / NR4018T2R2M (for 1.4 MHz), Taiyo Yuden CLF7045T-100M-D (for 210 kHz) / CLF6045NIT-2R2N-D (for 1.4 MHz), TDK
D1	CRS10I30A, TOSHIBA CRS10, TOSHIBA
D2-D7	1SS374, TOSHIBA
Tr1	2SA1586, TOSHIBA

Precautions for Selecting External Components

How to Set the Step-up Converter Output Voltage

V_{OUT1} of the step-up converter controls the voltage of V_{FB} pin, which should be $V_{FB} = 1.0$ V. It is possible to set V_{OUT1} voltage according to the following formula of R1 and R2 (refer to the *Typical Application*). V_{OUT1} voltage should be equal to or lower than 20 V. R1 + R2 should be equal to or lower than 500 k Ω .

$$V_{OUT1} = V_{FB} \times (R1 + R2) / R2$$

How to Set the Step-up Charge-pump Output Voltage

V_{OUT2} of the positive charge pump controls the voltage of C_{PPFB} pin, which should be $V_{PFB} = 1.5$ V. It is possible to set V_{OUT2} voltage according to the following formula of R3 and R4 (refer to the *Typical Application*). R3 + R4 should be equal to or less than 500 k Ω .

$$V_{OUT2} = V_{PFB} \times (R3 + R4) / R4$$

In the case of *Typical Application 1*, the maximum output voltage can be described as the following formula.

$$V_{OUT2} (\text{Max.}) = CPVCC \times 2 - V_F \times 2 \dots\dots\dots (V_F \text{ is the forward voltage for the diodes D2-D3})$$

Set C15, D6 and D7 of diodes, and C16 (1 μ F) (refer to the *Typical Application 2*) if the output voltage needs more than the range above. In this case, the maximum output voltage can be described as the following formula.

$$V_{OUT2} (\text{Max.}) = CPVCC \times 3 - V_F \times 4 \dots\dots\dots (V_F \text{ is the forward voltage for diodes D2-D3, D6-D7})$$

The maximum load current of the boost charge pump is determined by C_{fly} (C13, C15), the oscillator frequency of charge pump (f_{REQCP}), and CPP "L" On Resistance (R_{CPPL}) as described in the following formula.

$$I_{OUT2} (\text{Max.}) = C_{fly} \times (1 - \exp(-1 / (2 \times C_{fly} \times R_{CPPL} \times f_{REQCP}))) \times (CPVCC \times 2 - V_{OUT2} - V_F \times 2) \times f_{REQCP}$$

How to Set the Inverting Charge-pump Output Voltage

V_{OUT3} of the inverting charge-pump controls the voltage of C_{PNFB} pin, which should be $V_{NFB} = 0$ V. It is possible to set V_{OUT3} voltage by the following formula by R5 and R6 that are between V_{REF} pin and V_{OUT3} (refer to the *Typical Application*). R5 + R6 should be equal to or less than 500 k Ω

$$V_{OUT3} = V_{NFB} - (V_{REF} - V_{NFB}) \times R5 / R6$$

The minimum output voltage can be set by the following formula.

$$V_{OUT3} (\text{Min.}) = - (CPVCC - V_F \times 2) \dots\dots\dots (V_F \text{ is the forward voltage of the diode D4 and D5})$$

The maximum load current of inverting charge pump is determined by C_{fly} (C14), the oscillator frequency of charge pump (f_{REQCP}), and CPN "L" ON Resistance (R_{CPNL}) as described in the following formula.

$$I_{OUT3} (\text{Max.}) = C_{fly} \times (1 - \exp(-1 / (2 \times C_{fly} \times R_{CPNL} \times f_{REQCP}))) \times (CPVCC + V_{OUT3} - V_F \times 2) \times f_{REQCP}$$

How to set the Step-up DC/DC Converter's Phase Compensation (Refer to *Typical Application*)

In the DC/DC converter, with the load current and the external components (L and C) the phase may be delayed by 180 degrees. Due to this, the phase margin of system is lost and stability would be worse. Thus, it is necessary to proceed the phase, and keep a certain phase margin.

The phase compensation and the system gain can be set with using the resistor, R7 and capacitors, C7 and C8. The position and the setting values shown in the *Typical Application* are one of the examples.

Select R7 and C7, so that the cut-off frequency of this Zero point may become approximately the cutoff frequency of pole made by the external components (L and C). The following formula shows the pole made by the external components (L and C) and the "Zero" point.

$$F_{\text{pole}} \sim 1 / \{2 \times \pi \times \sqrt{L \times C1}\}$$

$$F_{\text{zero}} \sim 1 / (2 \times \pi \times R7 \times C7)$$

For example, when L = 4.7 μ H and C_{OUT} (C1) = 20 μ F, the cut-off frequency of the pole is approximately 16 kHz. Then set the cut-off frequency of the Zero point around 16 kHz to 1.6 kHz.

The gain can be set with the ratio of the resistance of R7 and combined resistance of R1 and R2 (RT: RT = R1 \times R2 / (R1 + R2)). If R7 is larger than the combined resistance (RT), the gain becomes high. If the gain is too high, the characteristics of response will be improved but the operating stability will be worse. Set R7 with an appropriate value.

Due to the R1 setting in the gain setting, another Zero point is set by R1 and C8. Set this cut-off frequency of Zero point at around the cut-off frequency by pole made by the external components (L and C). This Zero point is shown in the formula below.

$$F_{\text{zero}} \sim 1 / (2 \times \pi \times R1 \times C8)$$

Noise Reduction of the Feedback Voltage (Refer to *Typical Application*)

When the system noise is large, the output noise may be on to the feedback loop, and the operation may become unstable. In this case, set the value of the resistance R1 to R6 low and make the noise into the feedback reduction. It is possible to reduce the noise to the V_{FB} pin by connecting the resistance in the range from 1 k Ω to 5 k Ω around as R8.

Input Voltage

The range of V_{IN} voltage must be between 2.0 V and 5.5 V. For CPVCC pin, it is possible to use input V_{OUT1} or input another voltage of 6 V to 20 V to CPVCC as a power supply. In that case, set a capacitor of 1.0 μ F or more as C5 between GND and CPVCC pin.

How to Set the Oscillator Frequency

Set a resistor (R12) between GND and RT pin. The oscillator frequency of the step-up converter (f_{REQ}) can be set according to the next formula. This value depends upon the resistance value.

$$f_{REQ} = 2.7 \times 10^{10} / [0.8542 \times R12 \times \{0.66 + \sqrt{(0.66^2 + 12643 / R12)}\}]$$

Set the frequency between 210 kHz and 1400 kHz. The oscillator frequency of the charge-pump is one fourth of the oscillator frequency of the main step-up DC/DC converter.

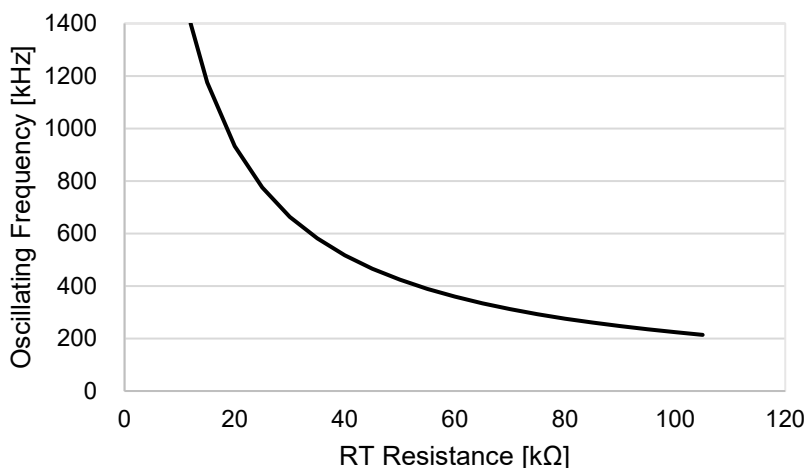

How to Set the Soft-start of Step-up Converter (Refer to the *Timing Chart*)

The soft-start of the step-up converter operates when V_{IN} is equal to or more than the UVLO release voltage, or when CE signal is “H”. External capacitor of SS pin (C9) is charged with the soft-start charge current (I_{SS}). Then the voltage of SS pin is input to the error amplifier as the reference voltage. When the voltage of SS pin reaches to the reference voltage (Typ.1.0 V) in the normal state, the reference voltage of the error amplifier stabilized at 1.0 V, and it changes to the normal state. The soft-start of step-up converter time (t_{SS}) is set by the external capacitor (C9) for the SS pin in the next formula.

$$t_{SS} = C9 \times V_{FB} / I_{SS}$$

How to Set the Start-up Sequence (Refer to the *Timing Chart*)

When the output voltage of step-up converter is up to 85% of a set value, and the soft-start is finished, the external capacitors (C10 and C11) of the CPPDLY pin and the CPNDLY pin are charged by the CPPDLY charge current (I_{PDLY}) and the CPNDLY charge current (I_{NDLY}). When the voltage of the CPPDLY pin and the CPNDLY pin charged up to the CPPDLY detector threshold (V_{PDLY}) and the CPNDLY detector threshold (V_{NDLY}), then the soft-start of the positive charge-pump and the negative charge-pump is operated respectively. After the step-up converter is operated, the delay time (t_{PDLY} and t_{NDLY}) until the soft-start of charge-pump is set by the external capacitors (C10 and C11) of the CPPDLY pin and the CPNDLY pin. The delay time is set by the following formula.

The delay time until the soft-start of positive charge-pump operates: $t_{PDLY} = C10 \times V_{PDLY} / I_{PDLY}$

The delay time until the soft-start of negative charge-pump operates: $t_{NDLY} = C11 \times V_{NDLY} / I_{NDLY}$

Thus, after the main step-up DC/DC converter starts operating, the positive charge-pump and the negative charge-pump can be operated by the arbitrary order.

Soft-start of the Charge-pump (Refer to *Typical Application and Timing Chart*)

When the soft-start of boost charge-pump operates, the output of CPPSW changes from "H" to "L". Setting the PNP-Tr1 (Tr1) keeps $V_{OUT2} = 0\text{ V}$ until the positive charge-pump is started. If it is not required to keep $V_{OUT2} = 0\text{ V}$, then PNP-Tr1 is unnecessary. In this case, V_{OUT2} outputs approximately the same voltage as V_{OUT1} . Arrange the resistor (R11) between the CPPSW pin and the base of PNP-Tr1 (Tr1). The maximum current of Tr1 can be set by the R11 value. This value can be calculated in the next formula.

$$I_{max} = hFE \times (V_{OUT1} - V_{BE}) / R11 \dots\dots [hFE \text{ is DC current gain of Tr1 and } V_{BE} \text{ is base emitter voltage of Tr1.}]$$

Select the appropriate value for R11 since the efficiency gets worse if the value is too small (refer to the *Short Current Protection* section. PNP-Tr1 has some effect on the operation of the short-current protection).

When the positive charge-pump starts, the reference voltage of the error amplifier starts from 0 V, turns on to the reference voltage (= 1.5 V) and becomes stable. Thus, the output voltage of V_{OUT2} can turn on by set output voltage within the time period of soft-start time.

In the initial state before starting the positive charge-pump, CPP pin generates High- level output voltage from the voltage supplied of CPVCC pin. Minim voltage of V_{OUT2} may occur when the "High" output voltage of CPP pin turns on by a rising of CPVCC voltage. The rising voltage level is susceptible to the rising width of CPVCC voltage ($CPVCC - V_{IN}$ under the normal condition), the capacitor C13 for CPP pin, and the capacitor C2 for V_{OUT2} . Since estimated calculation is $(CPVCC - V_{IN}) \times C13 / (C2 + C13)$, maximum voltage is about 0.79V for $V_{IN} = 3.3\text{V}$, $CPVCC = 12\text{V}$, $C13 = 0.1\mu\text{F}$, and $C2 = 1\mu\text{F}$.

Before the soft-start of the negative charge-pump starts, the reference voltage of the error amplifier rises to V_{REF} voltage (= 1.2 V) and falls down to 0 V in the soft start time fixed internally by the soft-start operation. Thus, the output voltage of V_{OUT3} can turn on by set output volatge within the time period of soft-start time.

How to set the Short Current Protection and Timer Latch Delay Time

If any output among the step-up converter output, the positive charge-pump output or the negative charge-pump output falls, the R1294L detects the short circuit. If this short circuit condition stays for a certain time, the latch-type protection circuit shuts down all the switching outputs (L_x , CPP, CPN) and outputs "H" through the CPPSW pin. Even if the switching stopped, the current path from CPVCC to V_{OUT2} is remained. If PNP-Tr is set on the CPPSW pin, the current path to V_{OUT2} is cut off after shutdown.

The detect voltages of V_{FB} , CPPFB and CPNFB are:

85% of predetermined V_{FB} voltage for V_{FB}

85% of predetermined CPPFB voltage for CPPFB

+ 0.15 V for CPNFB

The latch timer delay is set by an external capacitor (C12) of the DELAY pin. This delay time can be calculated by the next formula.

$$t_{DLY} = C12 \times V_{DLY} / I_{DLY}$$

To release the latch state, set V_{IN} voltage below UVLO detector threshold and restart, or Set the CE pin "L" once and change the CE pin to "H" level.

How to set the Maxduty Limit

The value of maxduty can be set by the input voltage to DTC pin. Set the voltage in which the V_{REF} output divided with the resistors R9 and R10. If the voltage of DTC pin increases more than the limit value, the lower value between the set value and the internally fixed value is selected and in valid.

TEST Pin

In terms of TEST pin, connect the GND level or remain it open.

Other Notes

- Use a 1.0 μF or higher capacitor (C4) in between GND and V_{IN} pin. Connect the capacitor as close as possible to the IC. If the noise level is large, use the 4.7 μF or higher capacitor is recommended.
- Use a 1.0 μF or higher capacitor (C1, C2, and C3) in between GND and each V_{OUT} (V_{OUT1} , V_{OUT2} , and V_{OUT3}). The recommended capacitance is $C1 = 4.7 \mu\text{F}$ to $22 \mu\text{F}$, $C2 = C3 = 1 \mu\text{F}$ to $2.2 \mu\text{F}$ (refer to the *Typical Application*).
- Use a 0.1 μF to 1 μF or higher capacitance (C6) in between V_{REF} and GND.
- To connect the GND of the capacitors (C9, C10, C11, and C12) for setting the delay time as short as possible to the GND of the IC.
- Selection of the diodes and inductors and capacitors should be considered. When Nch-switch turns on, the high voltage of spike by an inductor might be generated. Thus, using more than twice of the set output voltage for the voltage tolerance of the capacitor connecting to V_{OUT} is recommended. The diode and inductors should not exceed the rated value of the voltage, the current and the power .
- Select the diode with low forward voltage such as a Schottky barrier diode. The small reverse current and the fast switching speed type is desirable. Especially, the characteristics of diode (D1) influence the efficiency and the stability of the system.
- As the junction temperature rises, the switch limit current will decrease.
Make sure that the desired output current can be obtained even at high temperatures.
Also note that the output may overshoot significantly if the load suddenly changes from overcurrent protection.

TYPICAL CHARACTERISTICS

Typical Characteristics are intended to be used as reference data, they are not guaranteed.

1) V_{OUT1} (DCDC)

1-1) Output Voltage vs. Output Current

$f_{REQ} = 210kHz$, $V_{OUT} = 8.0V$

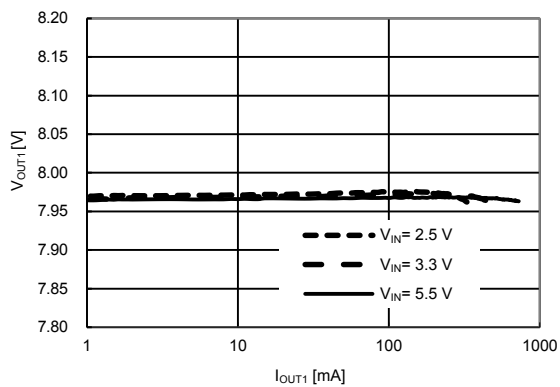

$f_{REQ} = 700kHz$, $V_{OUT} = 8.0V$

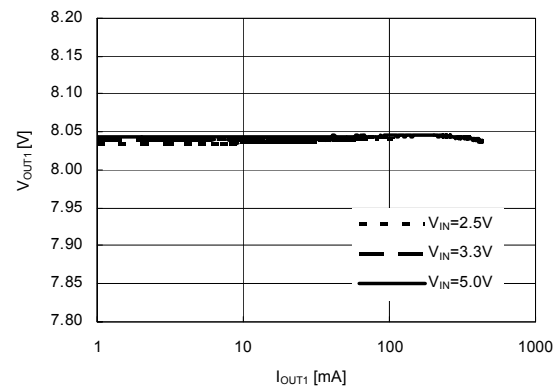

$f_{REQ} = 1400kHz$, $V_{OUT} = 8.0V$

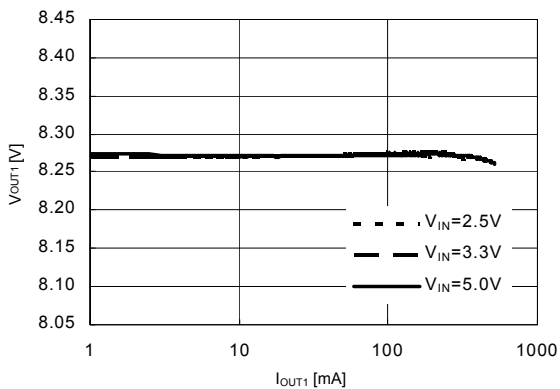

$f_{REQ} = 210kHz$, $V_{OUT} = 12.0V$

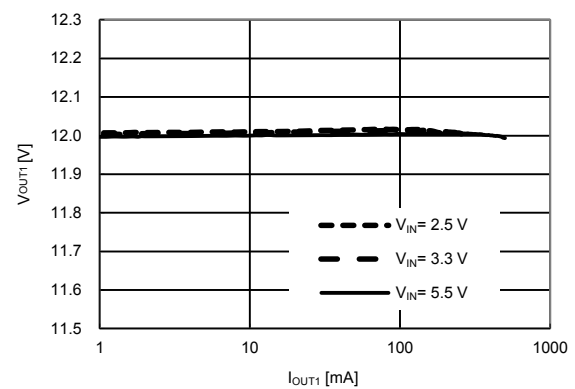

$f_{REQ} = 700kHz$, $V_{OUT} = 12.0V$

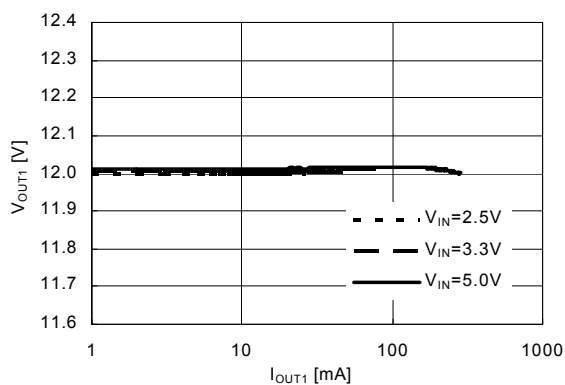

$f_{REQ} = 1400kHz$, $V_{OUT} = 12.0V$

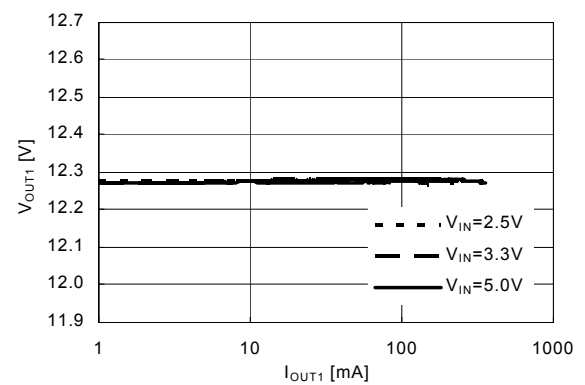

$f_{REQ} = 210kHz, V_{OUT} = 18.0V$

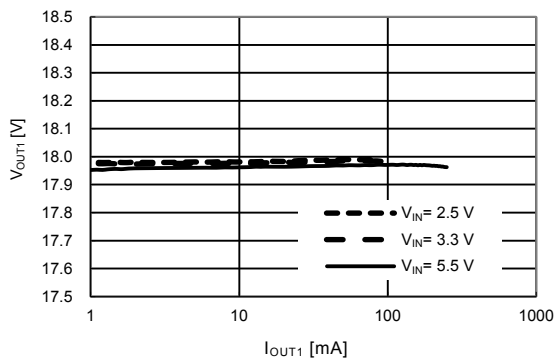

$f_{REQ} = 700kHz, V_{OUT} = 18.0V$

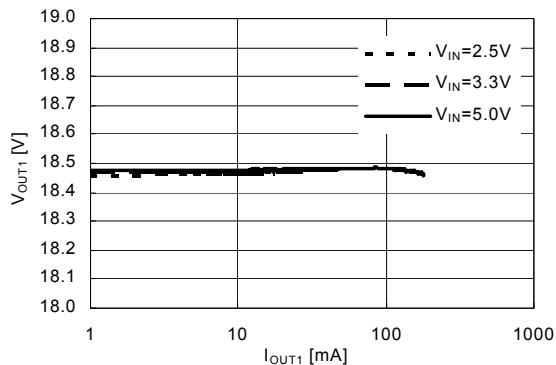

$f_{REQ} = 1400kHz, V_{OUT} = 18.0V$

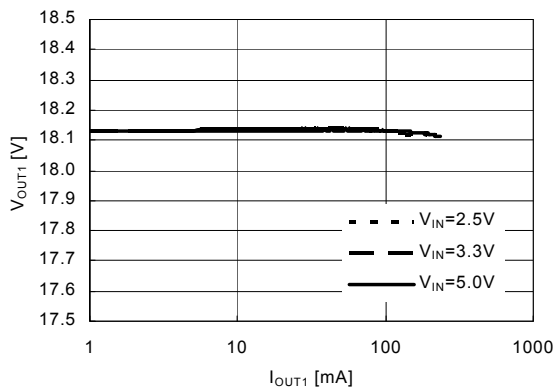

1-2) Efficiency vs. Output Current

$f_{REQ} = 210kHz, V_{OUT} = 8.0V$

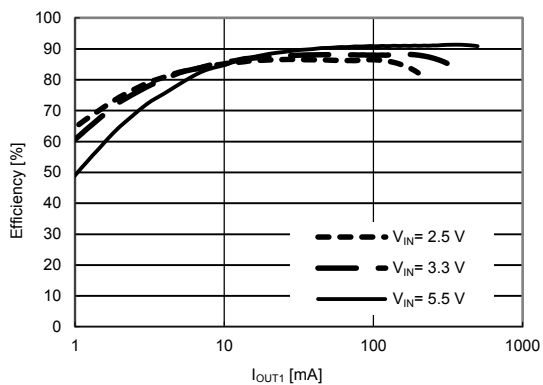

$f_{REQ} = 700kHz, V_{OUT} = 8.0V$

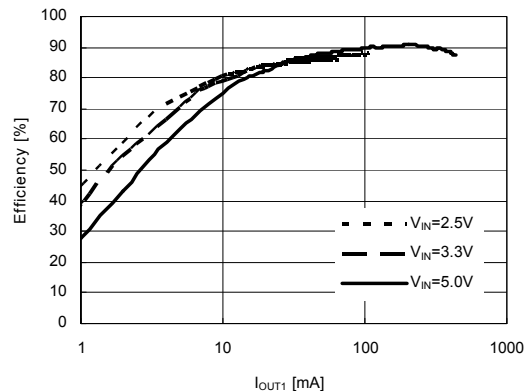

$f_{REQ} = 1400kHz, V_{OUT} = 8.0V$

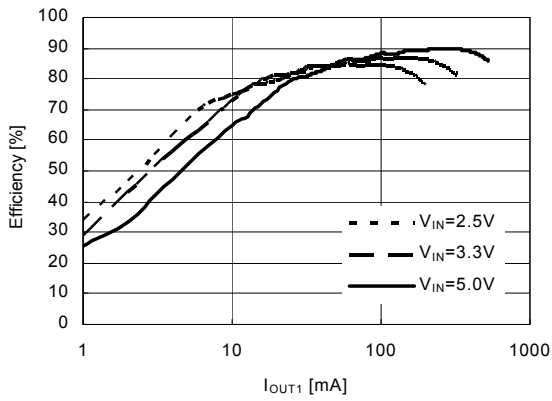

$f_{REQ} = 210kHz, V_{OUT} = 12.0V$

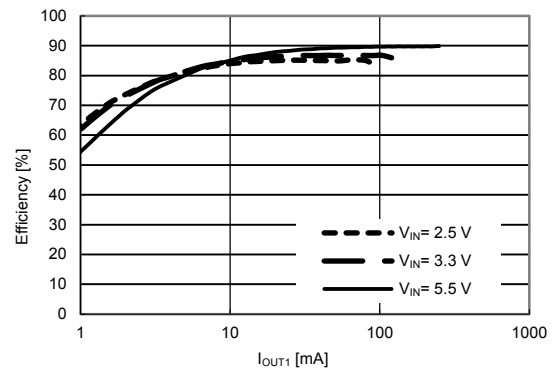

$f_{REQ} = 700kHz, V_{OUT} = 12.0V$

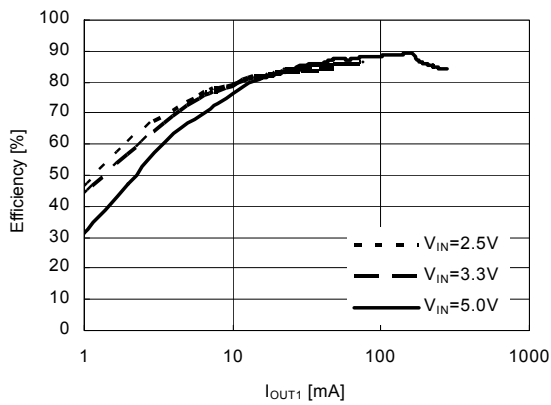

$f_{REQ} = 1400kHz, V_{OUT} = 12.0V$

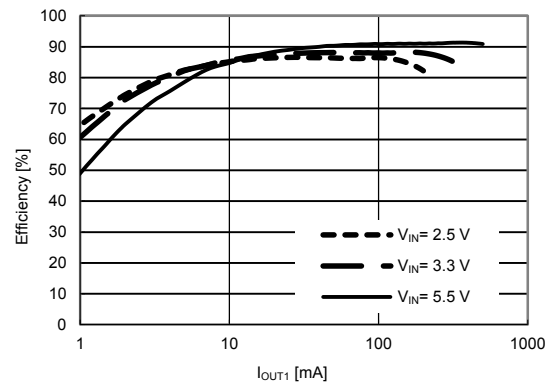

$f_{REQ} = 210kHz, V_{OUT} = 18.0V$

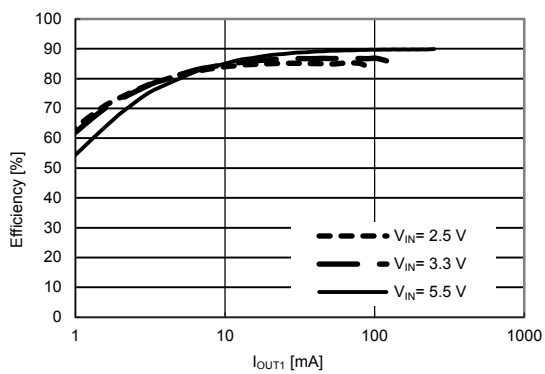

$f_{REQ} = 700kHz, V_{OUT} = 18.0V$

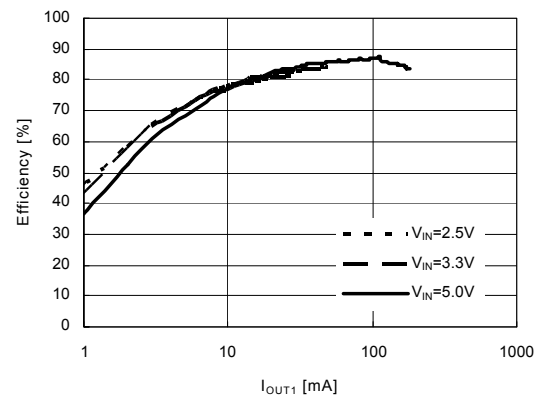

$f_{REQ} = 1400\text{kHz}$, $V_{OUT} = 18.0\text{V}$

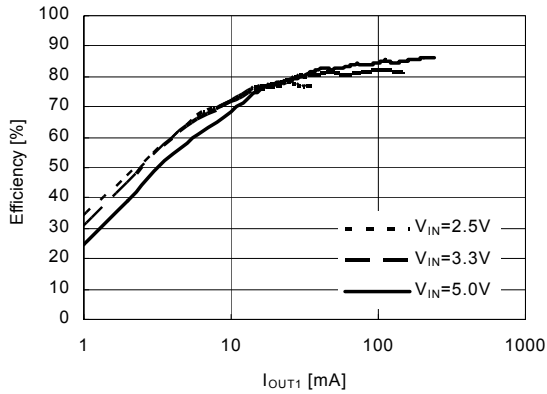

2) V_{OUT2} (Step-Up Charge-pump part)

2-1) Output Voltage vs. Output Current

$f_{REQ} = 700\text{kHz}$, $CPVCC = 8.0\text{V}$, $V_{OUT} = 12.0\text{V}$

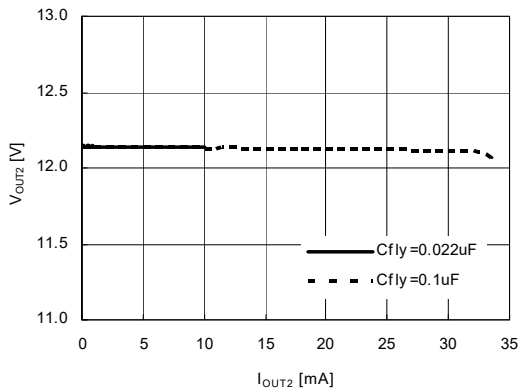

$f_{REQ} = 1400\text{kHz}$, $CPVCC = 8.0\text{V}$, $V_{OUT} = 12.0\text{V}$

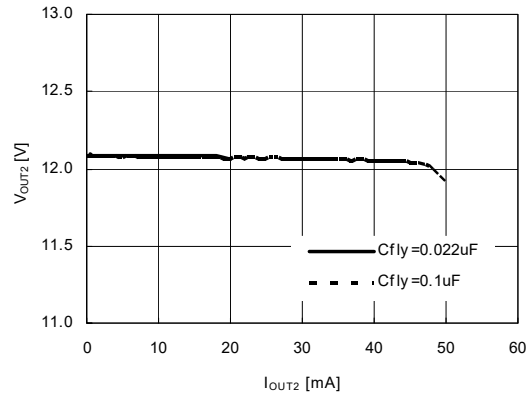

$f_{REQ} = 700\text{kHz}$, $CPVCC = 8.0\text{V}$, $V_{OUT} = 16.0\text{V}$

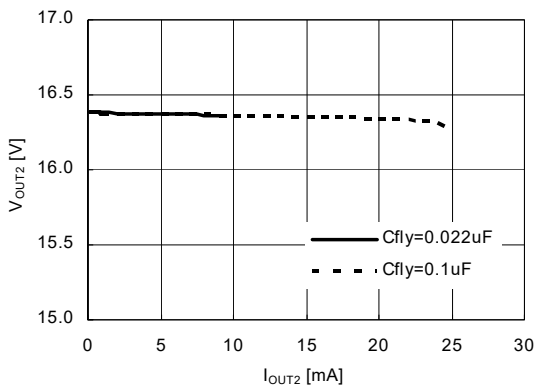

$f_{REQ} = 1400\text{kHz}$, $CPVCC = 8.0\text{V}$, $V_{OUT} = 16.0\text{V}$

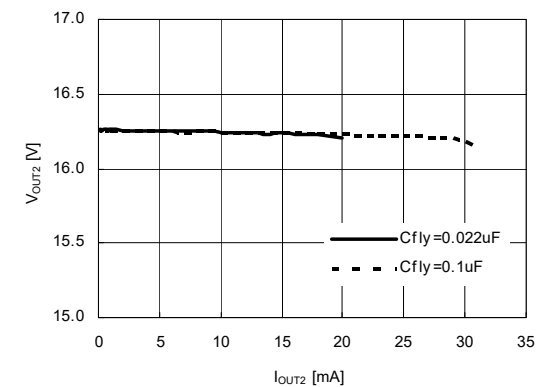

$f_{REQ} = 700\text{kHz}$, $CPVCC = 12.0\text{V}$, $V_{OUT} = 18.0\text{V}$

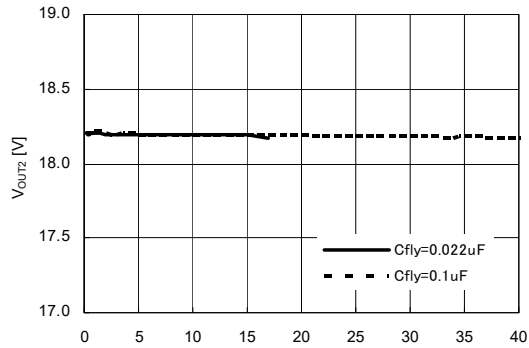

$f_{REQ} = 1400\text{kHz}$, $CPVCC = 12.0\text{V}$, $V_{OUT} = 18.0\text{V}$

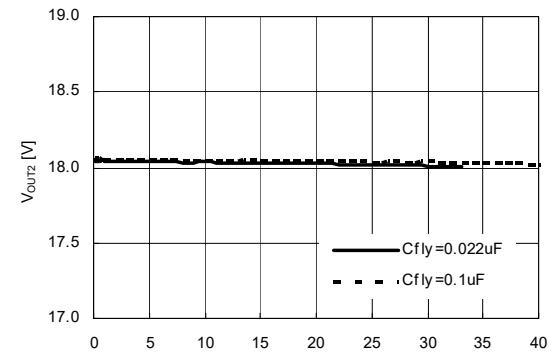

$f_{REQ} = 700\text{kHz}$, $CPVCC = 12.0\text{V}$, $V_{OUT} = 24.0\text{V}$

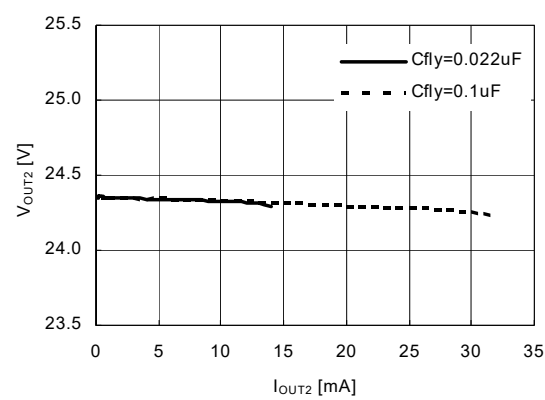

$f_{REQ} = 1400\text{kHz}$, $CPVCC = 12.0\text{V}$, $V_{OUT} = 24.0\text{V}$

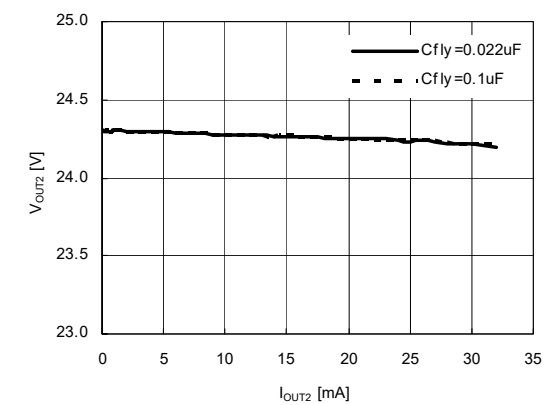

3) V_{OUT3} (Invert Charge-pump part)
3-1) Output Voltage vs. Output Current

$f_{REQ} = 700\text{kHz}$, $CPVCC = 8.0\text{V}$, $V_{OUT} = -6.0\text{V}$

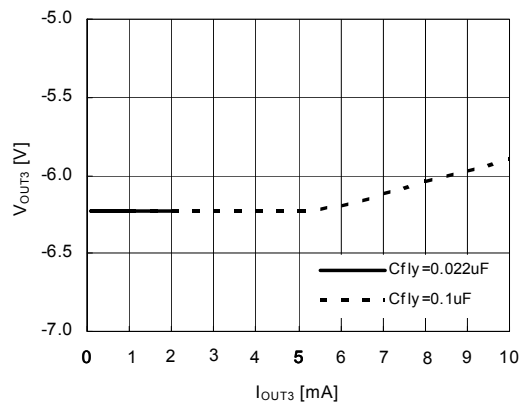

$f_{REQ} = 1400\text{kHz}$, $CPVCC = 8.0\text{V}$, $V_{OUT} = -6.0\text{V}$

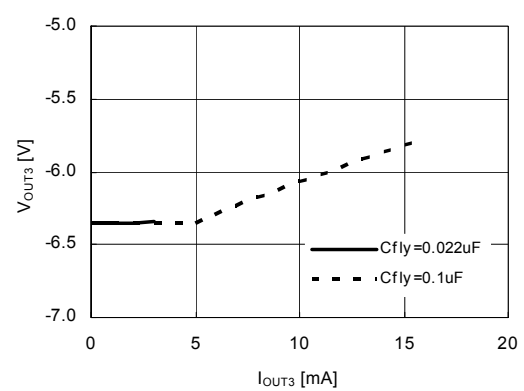

$f_{REQ} = 700\text{kHz}$, $CPVCC = 12.0\text{V}$, $V_{OUT} = -6.0\text{V}$

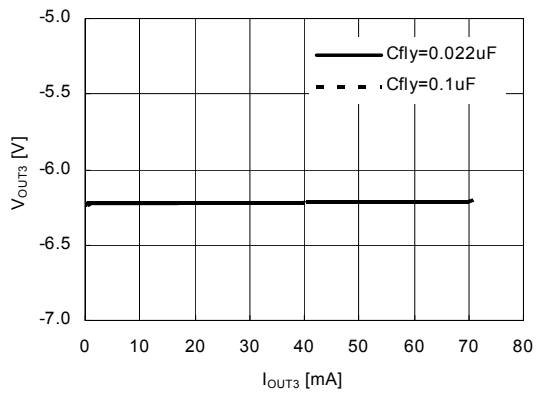

$f_{REQ} = 1400\text{kHz}$, $CPVCC = 12.0\text{V}$, $V_{OUT} = -6.0\text{V}$

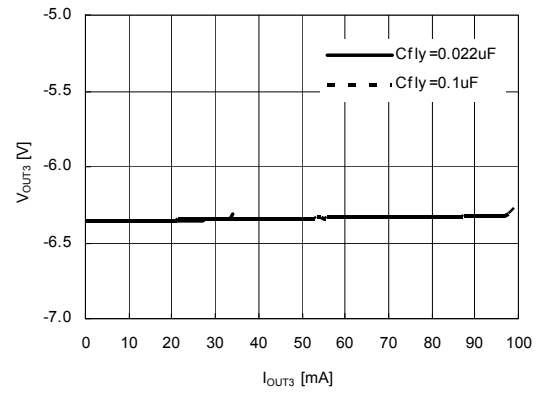

4) VFB Voltage vs. Input Voltage

$T_a = 25^\circ\text{C}$

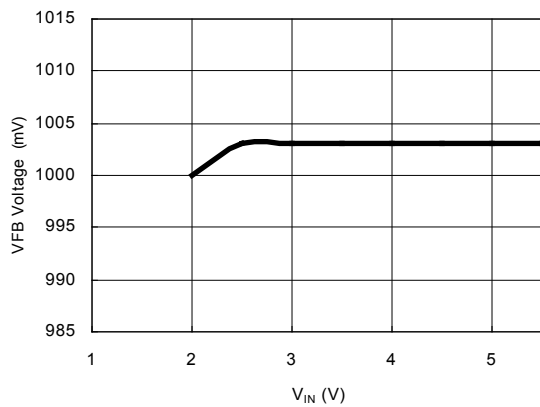

5) Oscillator Frequency vs. Input Voltage

$f_{REQ} = 210\text{kHz}$, $T_a = 25^\circ\text{C}$

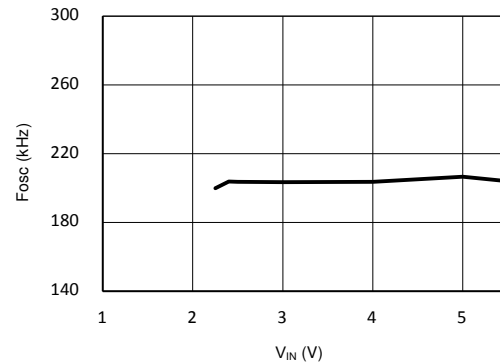

$f_{REQ} = 700\text{kHz}$, $T_a = 25^\circ\text{C}$

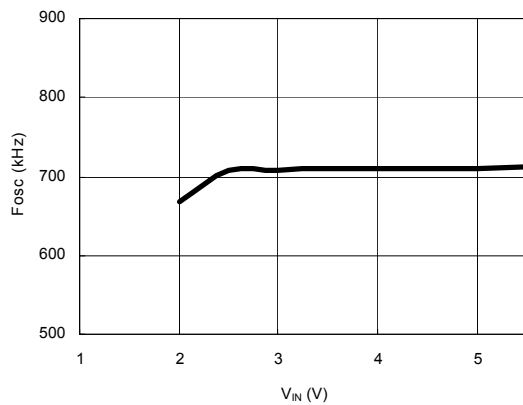

$f_{REQ} = 1400\text{kHz}$, $T_a = 25^\circ\text{C}$

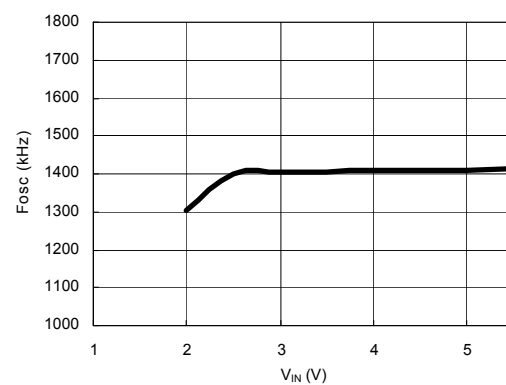

6) Supply Current vs. Input Voltage

$f_{REQ} = 210\text{kHz}$, $T_a = 25^\circ\text{C}$

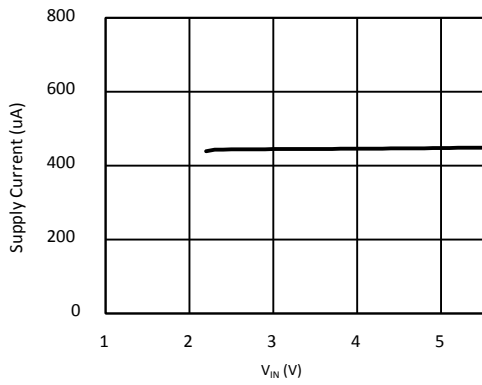

$f_{REQ} = 700\text{kHz}$, $T_a = 25^\circ\text{C}$

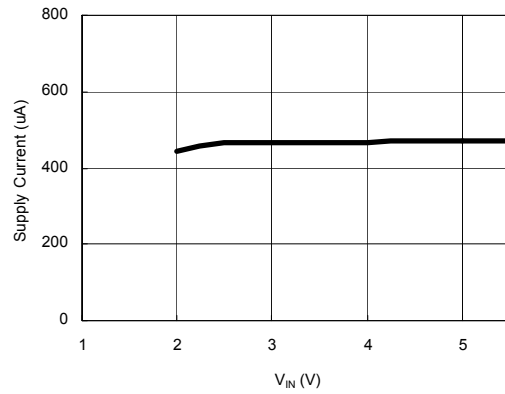

7) Maxduty vs. Input Voltage

$f_{REQ} = 1400\text{kHz}$, $T_a = 25^\circ\text{C}$

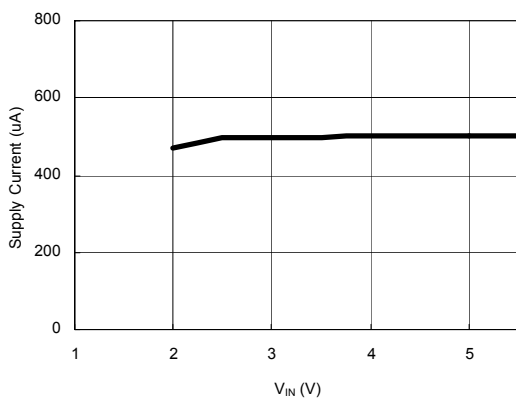

$T_a = 25^\circ\text{C}$

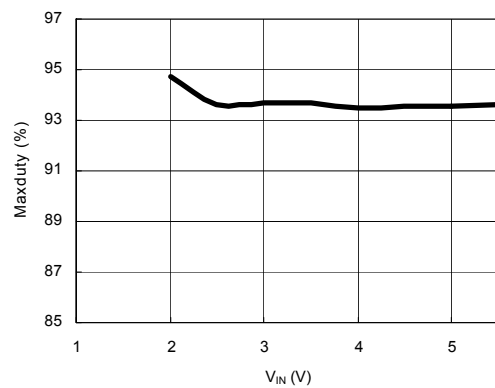

8) VIN Supply Current vs. Temperature

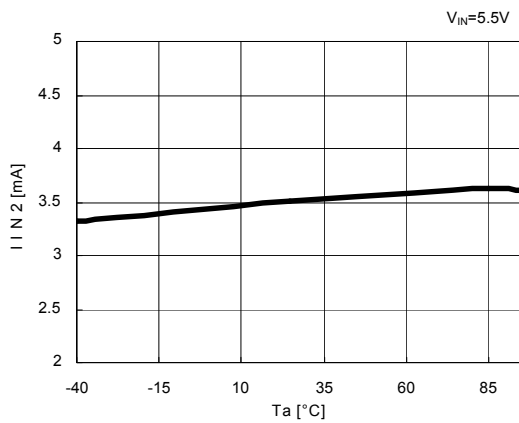

9) CP Supply Current vs. Temperature

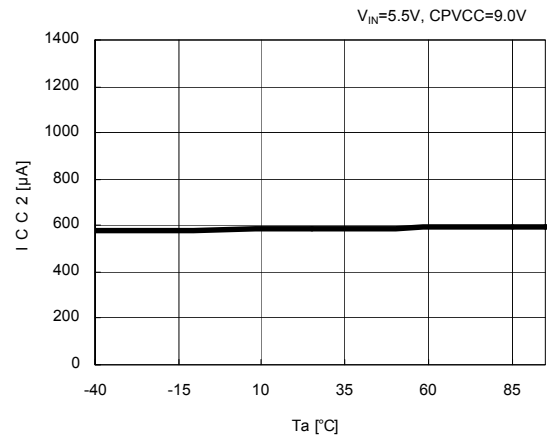

10) UVLO Detect Voltage vs. Temperature

R1294L101A

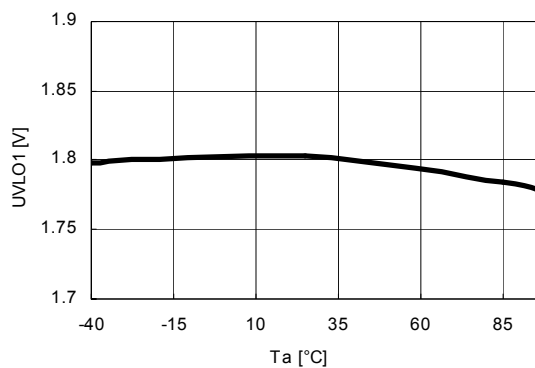

R1294L102A

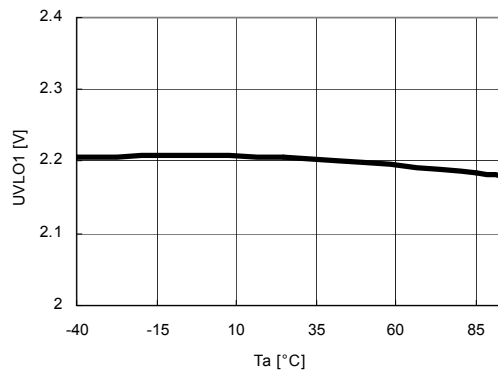

11) UVLO Release Voltage vs. Temperature

R1294L103A

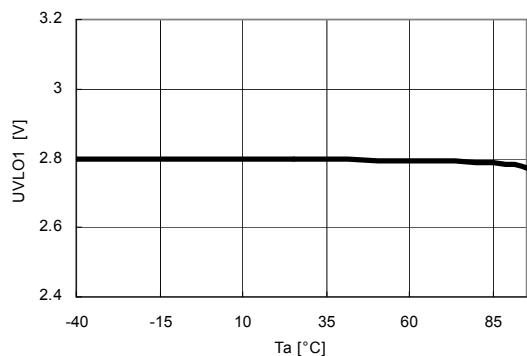

R1294L101A

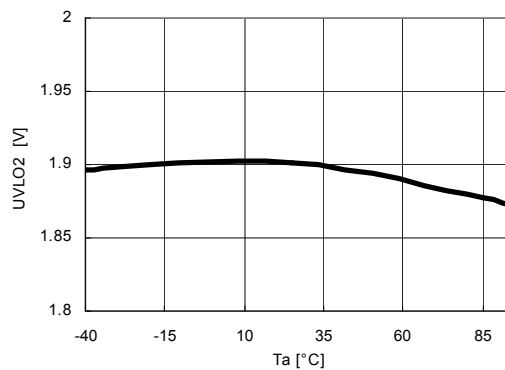

R1294L102A

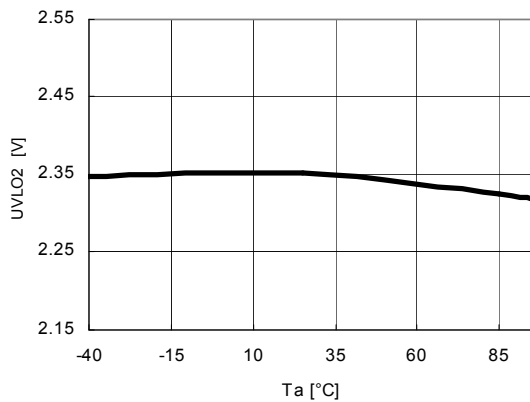

R1294L103A

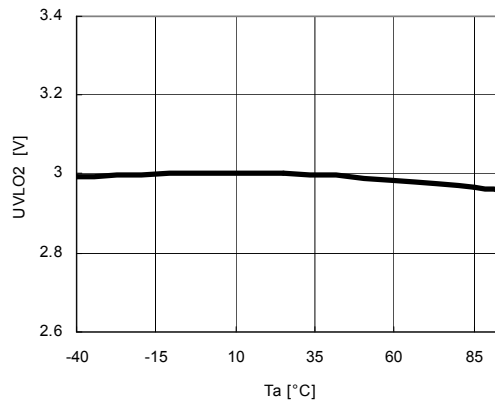

12) VFB Voltage vs. Temperature

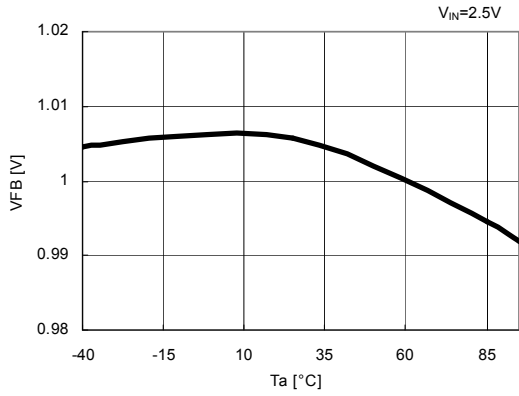

13) Maxduty vs. Temperature

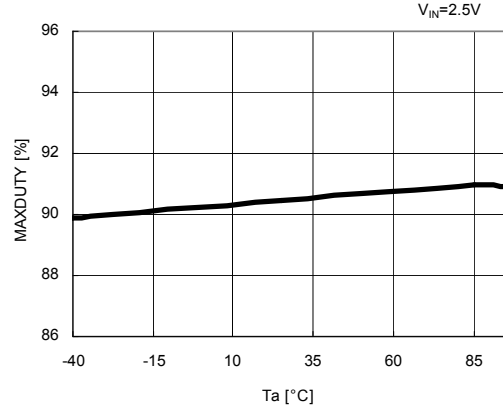

14) AMP"H"Output Current vs. Temperature

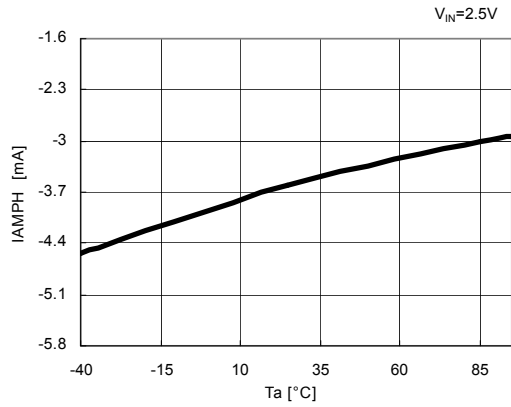

15) AMP"L'Output Current vs. Temperature

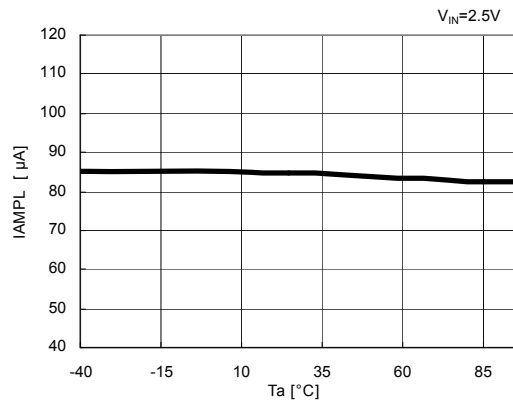

16) Switch ON Resistance vs. Temperature

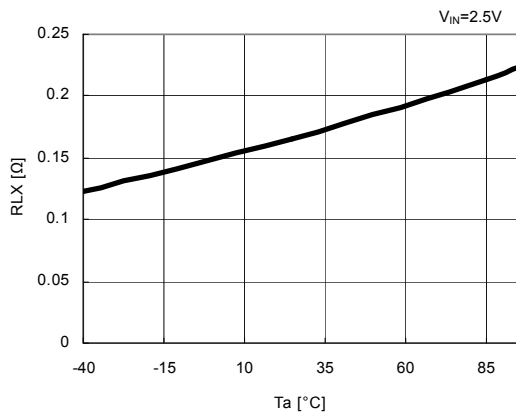

17) Switch Leakage Current vs. Temperature

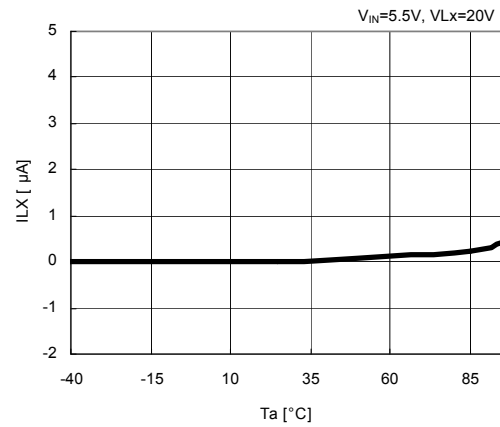

18) Switch Limit Current vs. Temperature

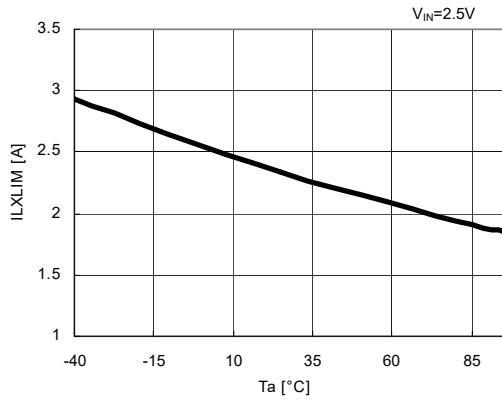

19) Oscillator Frequency vs. Temperature

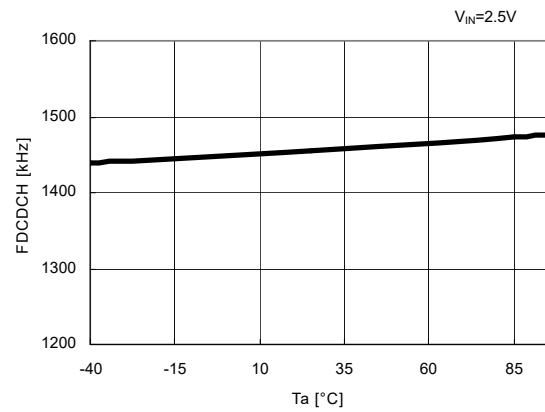
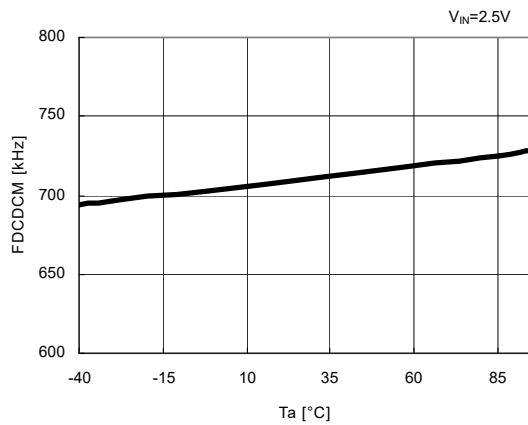
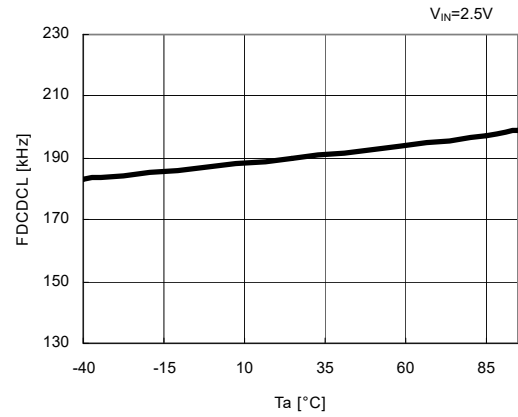

20) VREF Voltage vs. Temperature

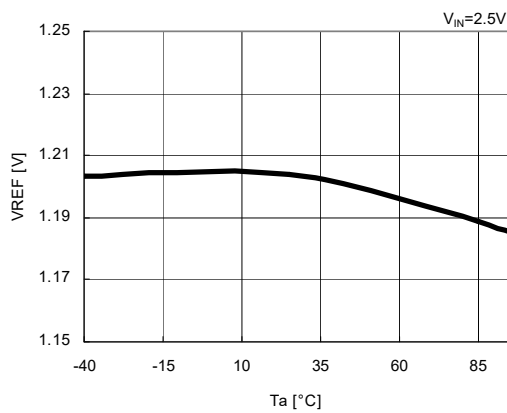

21) Terminal SS charge current vs. Temperature

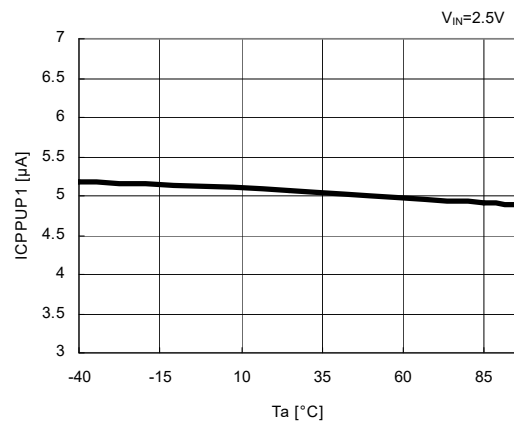

22) CPP Soft-Start vs. Temperature

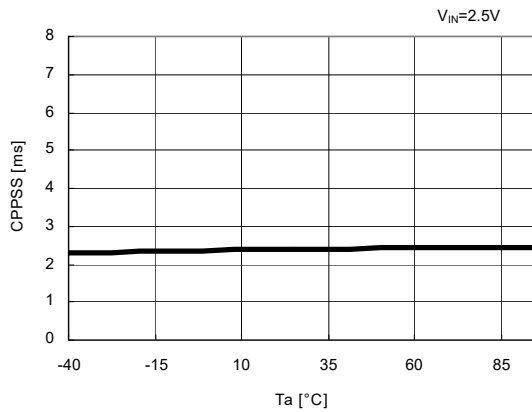

23) CPN Soft-Start vs. Temperature

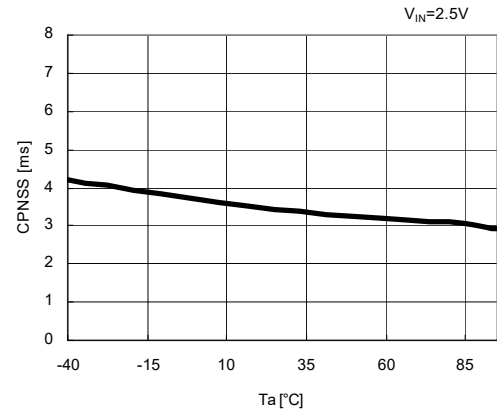

24) CPPDLY Charge Current vs. Temperature

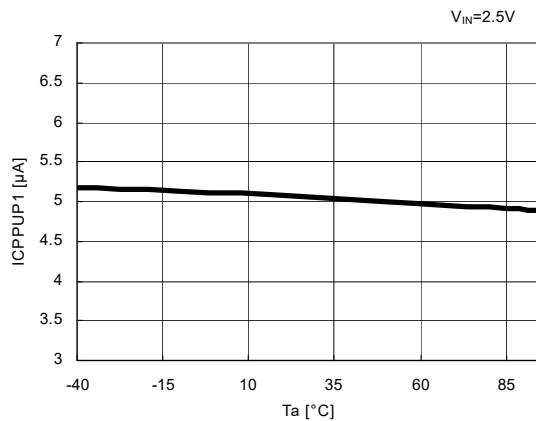

25) CPNDLY Charge Current vs. Temperature

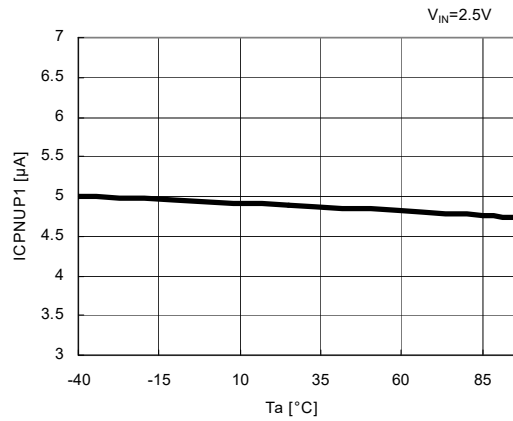

26) CPPDLY Detector Threshold vs. Temperature

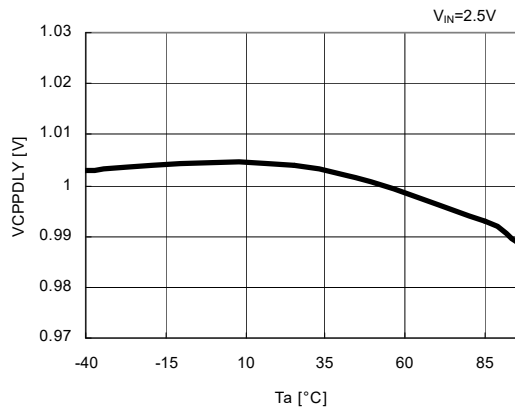

27) CPNDLY Detector Threshold vs. Temperature

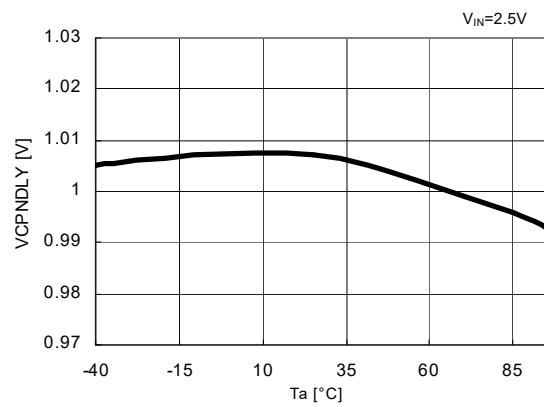

28) CPPFB Voltage vs. Temperature

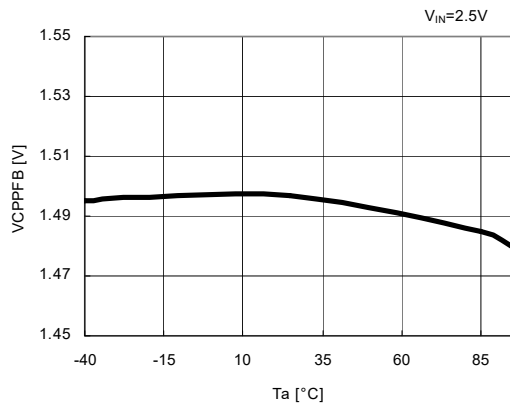

29) CPNFB Voltage vs. Temperature

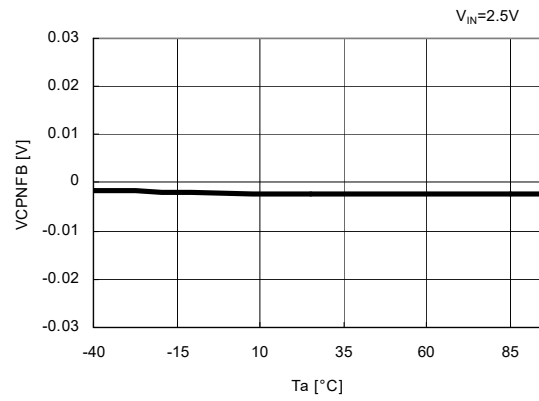

30) CPPH^{ON} Resistance vs. Temperature

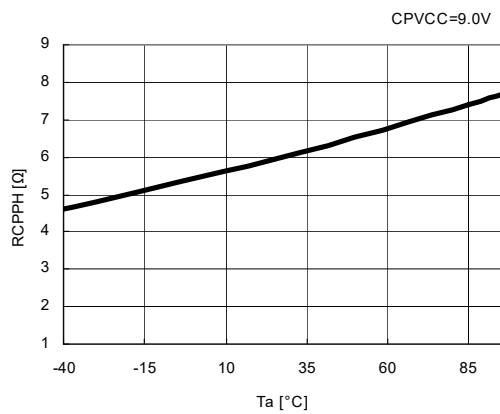

31) CPP^LON Resistance vs. Temperature

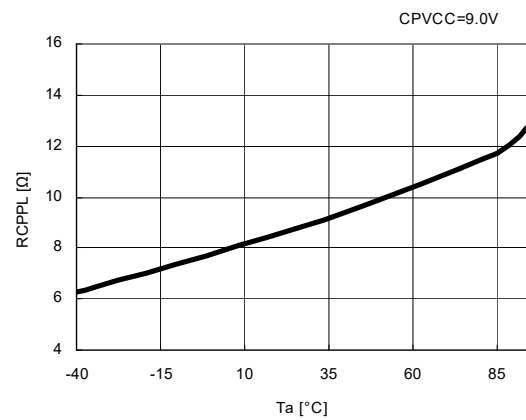

32) CPNH^{ON} Resistance vs. Temperature

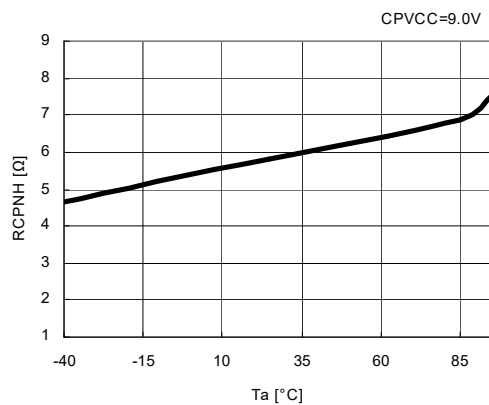

33) CPN^LON Resistance vs. Temperature

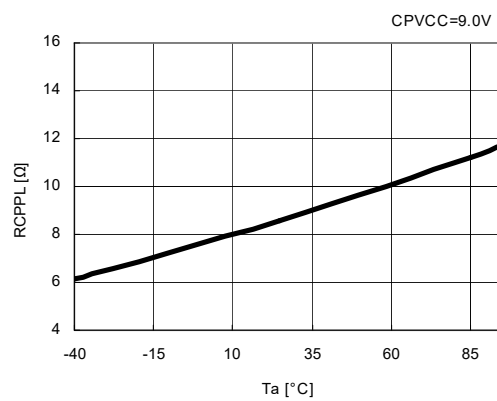

34) Charge-pump Frequency vs. Temperature

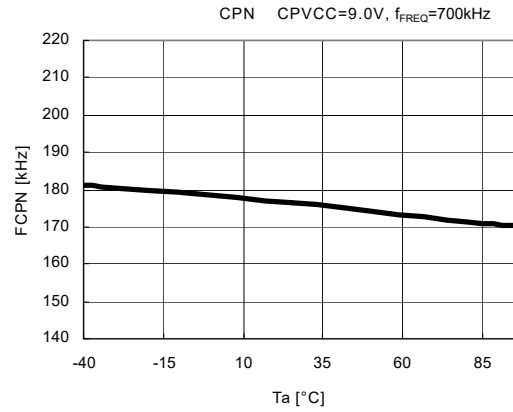
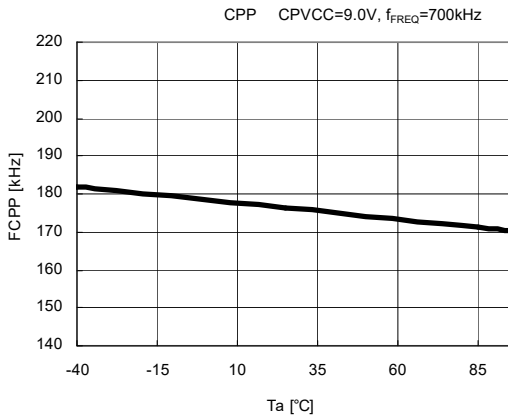

35) DELAY Charge Current vs. Temperature

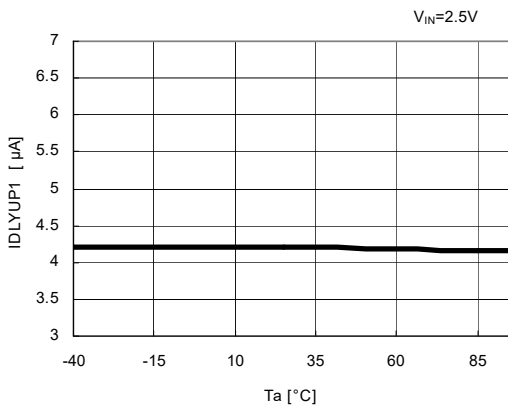

36) DELAY Discharge Current vs. Temperature

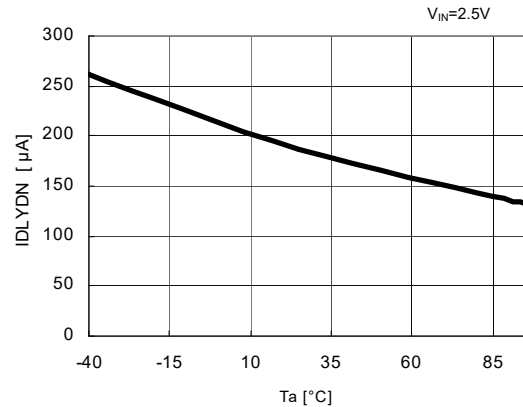

37) DELAY Detector Threshold vs. Temperature

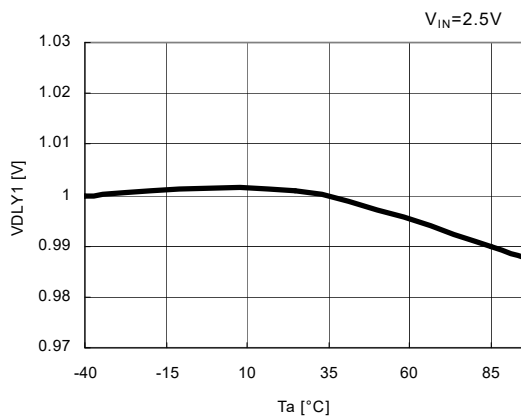

38) CPPSW "L" Output Voltage vs. Temperature

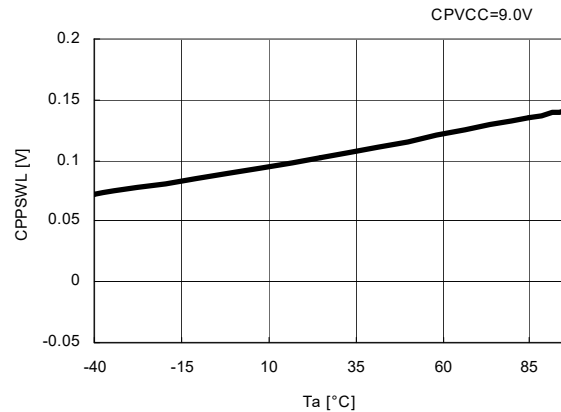

39) Standby Current vs. Temperature

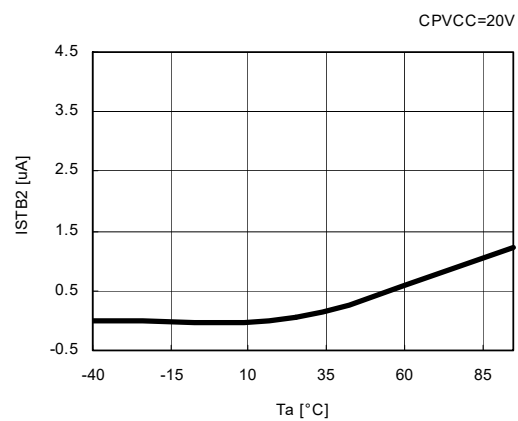
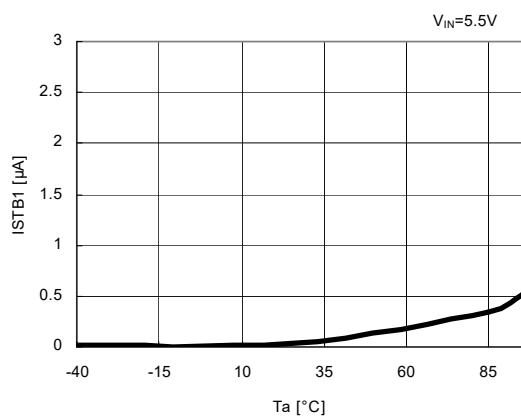

40) CE "L" Input Current vs. Temperature

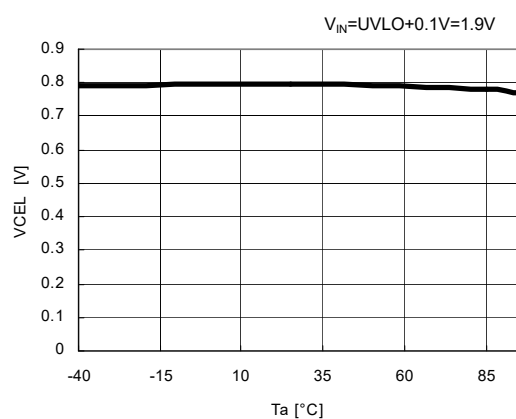

41) CE "H" Input Current vs. Temperature

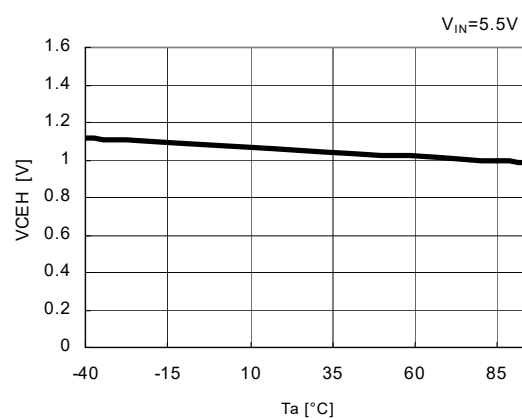

42) Load Transient Response

R1294L102A

$V_{IN}=3.3V$, $V_{OUT}=8V$, $I_{OUT}=1mA - 100mA$, $f_{REQ} = 210kHz$

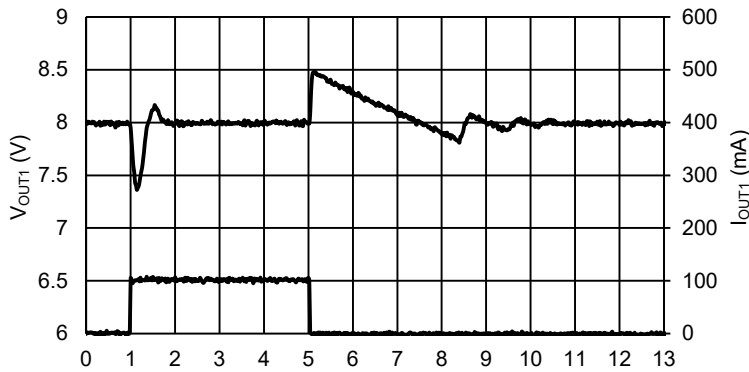

L	10uH
C1	20uF
R1	70kΩ
R2	10kΩ
C7	4700pF
R7	10kΩ
C8	220pF
R8	1kΩ

$V_{IN}=3.3V$, $V_{OUT}=12V$, $I_{OUT}=1mA - 100mA$, $f_{REQ} = 210kHz$

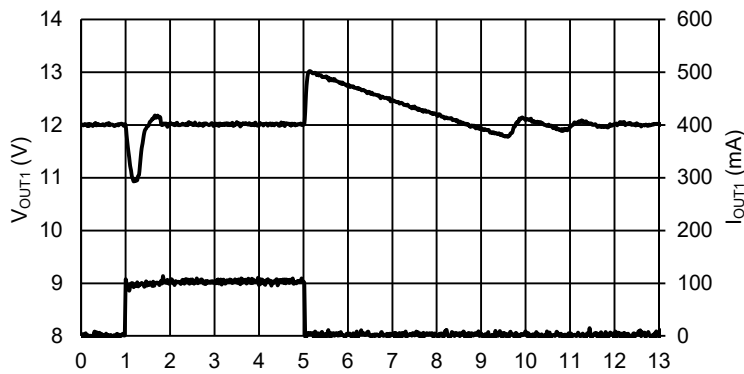

L	10uH
C1	20uF
R1	110kΩ
R2	10kΩ
C7	4700pF
R7	10kΩ
C8	220pF
R8	1kΩ

$V_{IN}=3.3V$, $V_{OUT}=16V$, $I_{OUT}=1mA - 100mA$, $f_{REQ} = 210kHz$

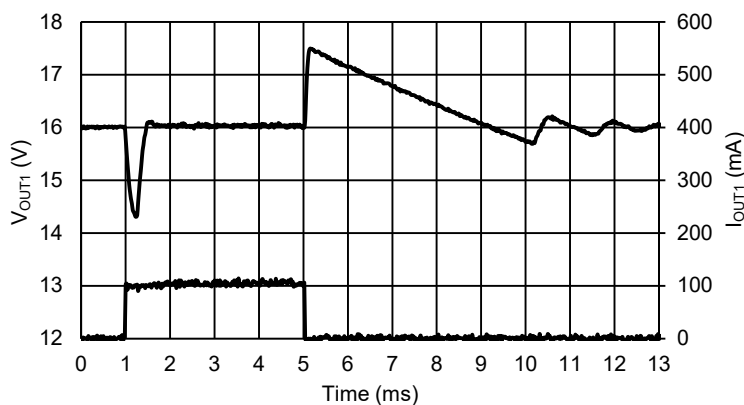

L	10uH
C1	20uF
R1	150kΩ
R2	10kΩ
C7	4700pF
R7	10kΩ
C8	220pF
R8	1kΩ

R1294L102A

$V_{IN}=3.3V$, $V_{OUT}=8V$, $I_{OUT}=1mA - 100mA$, $f_{REQ}=800kHz$

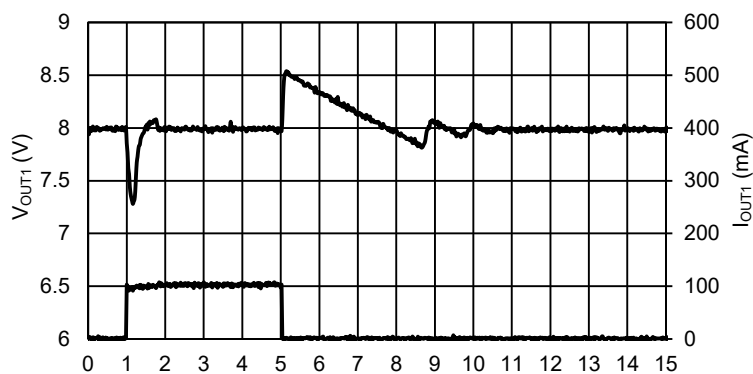

L	4.7uH
C1	20uF
R1	70kΩ
R2	10kΩ
C7	4700pF
R7	10kΩ
C8	100pF
R8	1kΩ

$V_{IN}=3.3V$, $V_{OUT}=12V$, $I_{OUT}=1mA - 100mA$, $f_{REQ}=800kHz$

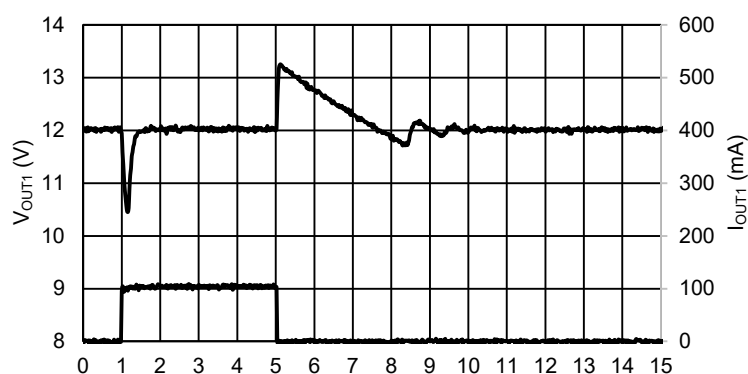

L	4.7uH
C1	10uF
R1	110kΩ
R2	10kΩ
C7	4700pF
R7	10kΩ
C8	100pF
R8	1kΩ

$V_{IN}=3.3V$, $V_{OUT}=16V$, $I_{OUT}=1mA - 100mA$, $f_{REQ}=800kHz$

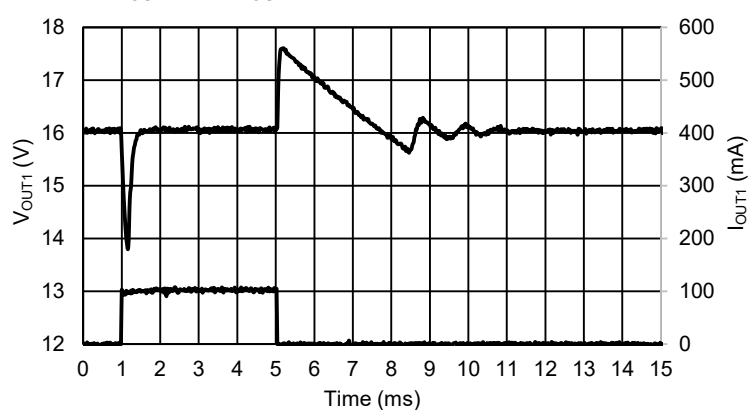

L	4.7uH
C1	10uF
R1	150kΩ
R2	10kΩ
C7	4700pF
R7	10kΩ
C8	100pF
R8	1kΩ

R1294L102A

$V_{IN}=3.3V$, $V_{OUT}=8V$, $I_{OUT}=1mA - 100mA$, $f_{REQ} = 1400kHz$

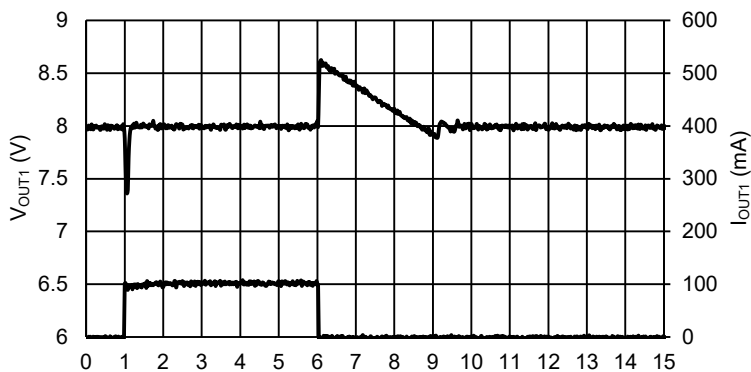

L	2.2uH
C1	20uF
R1	70kΩ
R2	10kΩ
C7	2200pF
R7	10kΩ
C8	47pF
R8	1kΩ

$V_{IN}=3.3V$, $V_{OUT}=12V$, $I_{OUT}=1mA - 100mA$, $f_{REQ} = 1400kHz$

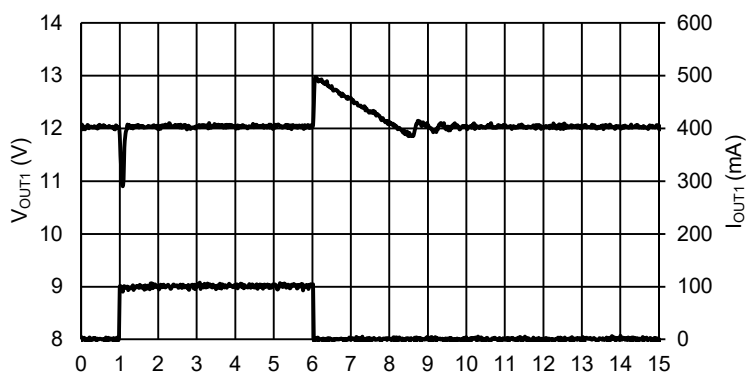

L	2.2uH
C1	10uF
R1	110kΩ
R2	10kΩ
C7	2200pF
R7	10kΩ
C8	47pF
R8	1kΩ

$V_{IN}=3.3V$, $V_{OUT}=16V$, $I_{OUT}=1mA - 100mA$, $f_{REQ} = 1400kHz$

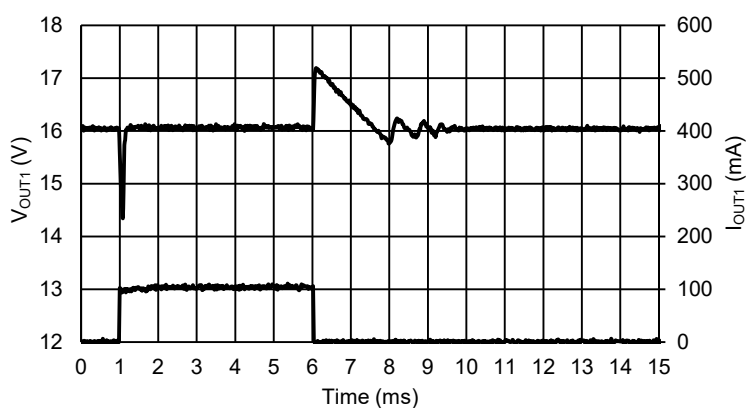

L	2.2uH
C1	10uF
R1	150kΩ
R2	10kΩ
C7	2200pF
R7	10kΩ
C8	47pF
R8	1kΩ

43) CE Switch Response

R1294L102A

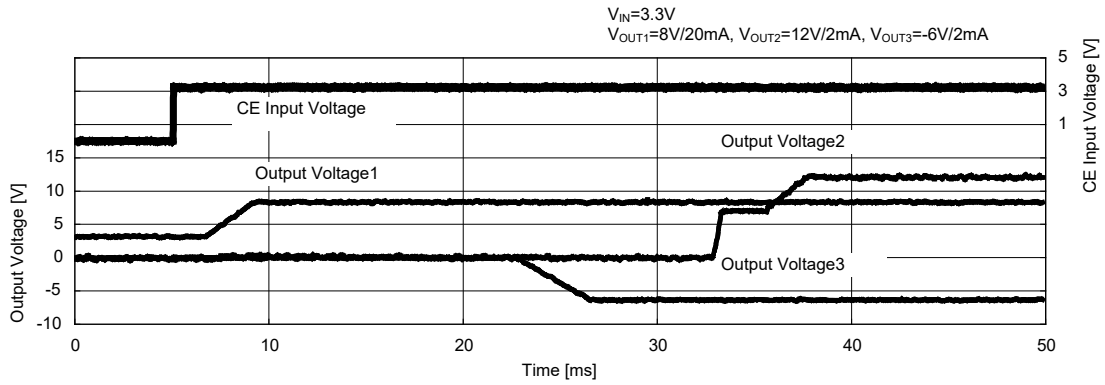

R1294L102A

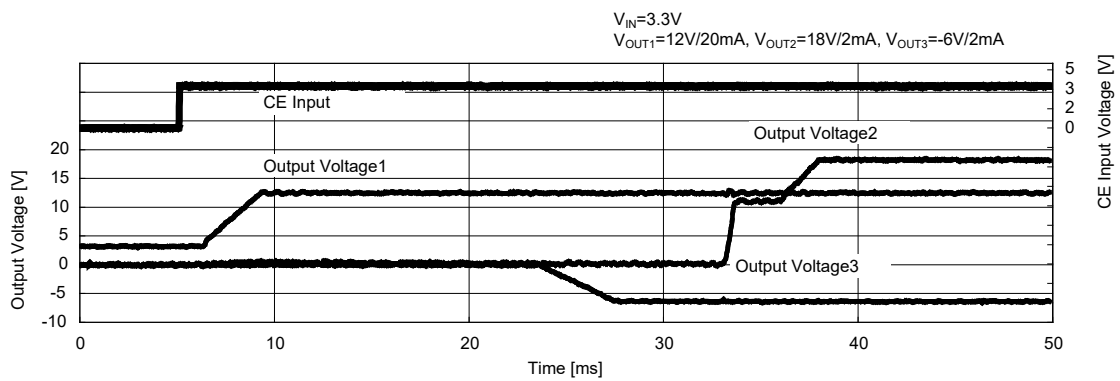

R1294L102A

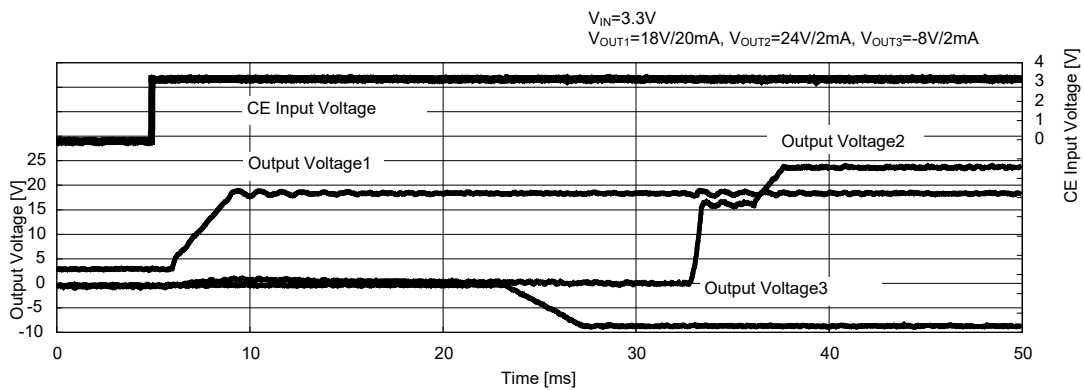

The power dissipation of the package is dependent on PCB material, layout, and environmental conditions. The following measurement conditions are based on JEDEC STD. 51-7.

Measurement Conditions

Item	Measurement Conditions
Environment	Mounting on Board (Wind Velocity = 0 m/s)
Board Material	Glass Cloth Epoxy Plastic (Four-Layer Board)
Board Dimensions	76.2 mm × 114.3 mm × 0.8 mm
Copper Ratio	Outer Layer (First Layer): Less than 95% of 50 mm Square Inner Layers (Second and Third Layers): Approx. 100% of 50 mm Square Outer Layer (Fourth Layer): Approx. 100% of 50 mm Square
Through-holes	φ 0.3 mm × 45 pcs

Measurement Result

(Ta = 25°C, Tjmax = 125°C)

Item	Measurement Result
Power Dissipation	3400 mW
Thermal Resistance (θja)	θja = 29°C/W
Thermal Characterization Parameter (ψjt)	ψjt = 10°C/W

θja: Junction-to-Ambient Thermal Resistance

ψjt: Junction-to-Top Thermal Characterization Parameter

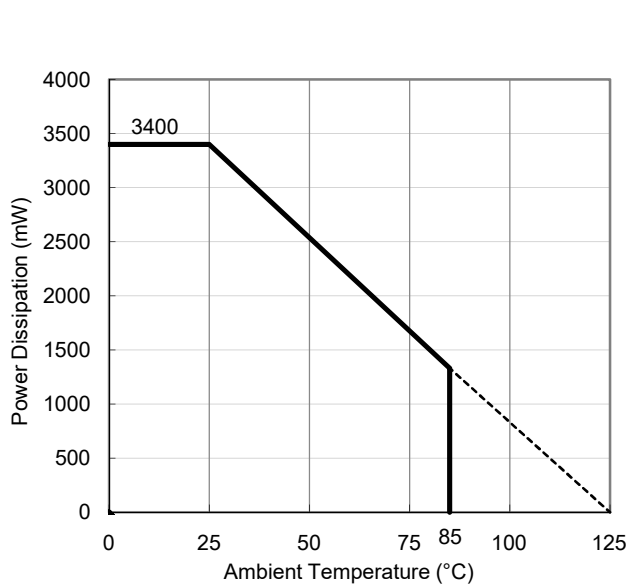

Power Dissipation vs. Ambient Temperature

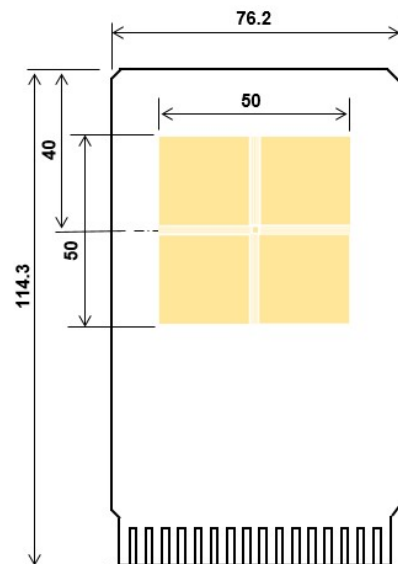

Measurement Board Pattern

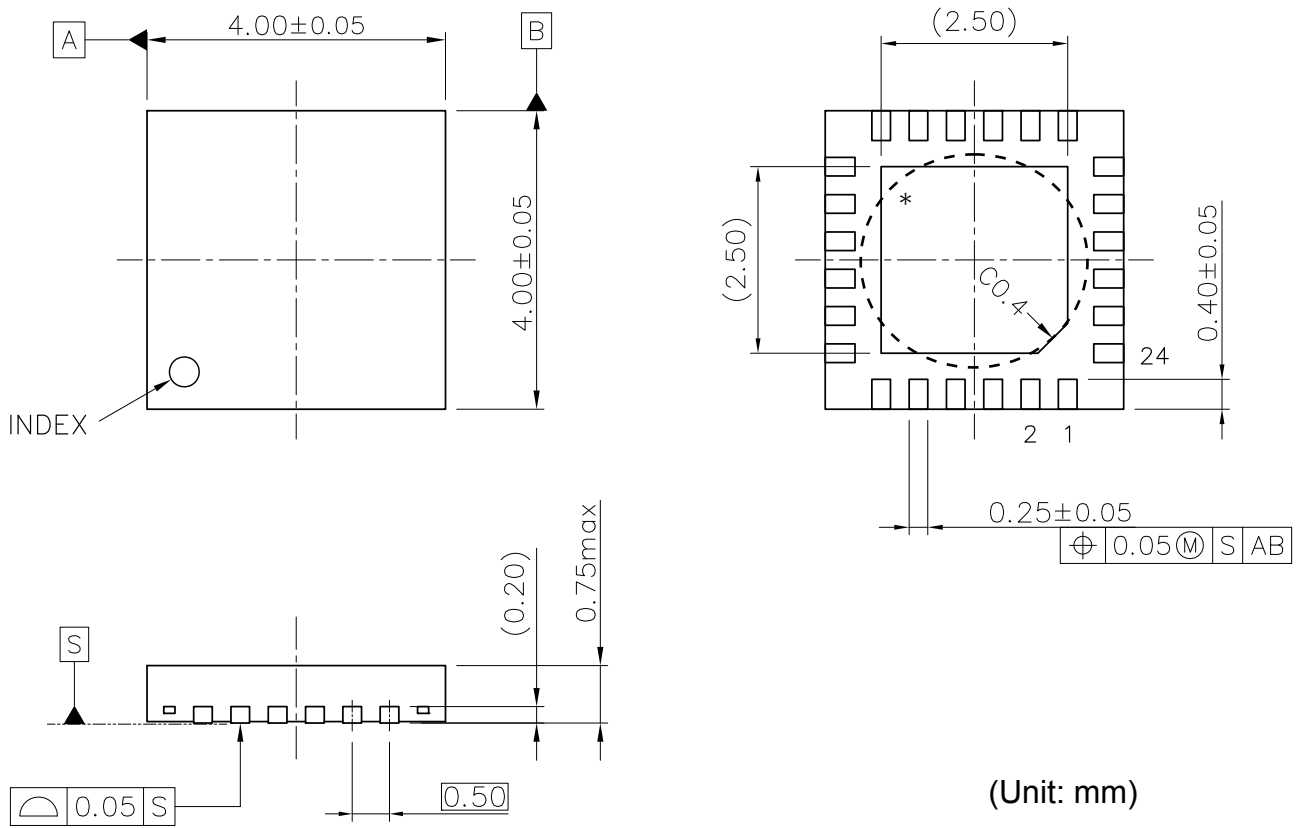

* The tab on the bottom of the package enhances thermal performance and is electrically connected to GND (substrate level). The tab is recommended to connect to the ground plane on the board. Otherwise it may be left floating.

QFN0404-24B Package Dimensions



1. The products and the product specifications described in this document are subject to change or discontinuation of production without notice for reasons such as improvement. Therefore, before deciding to use the products, please refer to our sales representatives for the latest information thereon.
2. The materials in this document may not be copied or otherwise reproduced in whole or in part without prior written consent of our company.
3. Please be sure to take any necessary formalities under relevant laws or regulations before exporting or otherwise taking out of your country the products or the technical information described herein.
4. The technical information described in this document shows typical characteristics of and example application circuits for the products. The release of such information is not to be construed as a warranty of or a grant of license under our company's or any third party's intellectual property rights or any other rights.
5. The products listed in this document are intended and designed for use as general electronic components in standard applications (office equipment, telecommunication equipment, measuring instruments, consumer electronic products, amusement equipment etc.). Those customers intending to use a product in an application requiring extreme quality and reliability, for example, in a highly specific application where the failure or misoperation of the product could result in human injury or death (aircraft, spacevehicle, nuclear reactor control system, traffic control system, automotive and transportation equipment, combustion equipment, safety devices, life support system etc.) should first contact us.
6. We are making our continuous effort to improve the quality and reliability of our products, but semiconductor products are likely to fail with certain probability. In order to prevent any injury to persons or damages to property resulting from such failure, customers should be careful enough to incorporate safety measures in their design, such as redundancy feature, fire containment feature and fail-safe feature. We do not assume any liability or responsibility for any loss or damage arising from misuse or inappropriate use of the products.
7. Anti-radiation design is not implemented in the products described in this document.
8. The X-ray exposure can influence functions and characteristics of the products. Confirm the product functions and characteristics in the evaluation stage.
9. WLCSP products should be used in light shielded environments. The light exposure can influence functions and characteristics of the products under operation or storage.
10. There can be variation in the marking when different AOI (Automated Optical Inspection) equipment is used. In the case of recognizing the marking characteristic with AOI, please contact our sales or our distributor before attempting to use AOI.
11. Please contact our sales representatives should you have any questions or comments concerning the products or the technical information.



Nisshinbo Micro Devices Inc.

Official website

<https://www.nisshinbo-microdevices.co.jp/en/>

Purchase information

<https://www.nisshinbo-microdevices.co.jp/en/buy/>

