

### FEATURES

**Operating Temperature Range:  $-40^{\circ}\text{C}$  to  $+105^{\circ}\text{C}$**   
**Single-Supply Operation: 4 V to 30 V**  
**Excellent Repeatability and Stability**  
**High Level Output:  $1\ \mu\text{A}/\text{K}$**   
**Monolithic IC: Temperature In/Current Out**  
**Minimal Self-Heating Errors**

### APPLICATIONS

**Appliance Temperature Sensor**  
**Automotive Temperature Measurement and Control**  
**HVAC System Monitoring**  
**Industrial Temperature Control**  
**Thermocouple Cold Junction Compensation**

### GENERAL DESCRIPTION

The TMP17 is a monolithic integrated circuit temperature transducer that provides an output current proportional to absolute temperature. For a wide range of supply voltages, the transducer acts as a high impedance temperature dependent current source of  $1\ \mu\text{A}/\text{K}$ . Improved design and laser wafer trimming of the IC's thin-film resistors allow the TMP17 to achieve absolute accuracy levels and nonlinearity errors previously unattainable at a comparable price.

The TMP17 can be employed in applications from  $-40^{\circ}\text{C}$  to  $+105^{\circ}\text{C}$  where conventional temperature sensors (i.e., thermistor, RTD, thermocouple, diode) are currently being used. Expensive linearization circuitry, precision voltage references, bridge components, resistance measuring circuitry, and cold junction compensation are not required with the TMP17.

The TMP17 is available in a low cost SOIC-8 surface-mount package.

### PRODUCT HIGHLIGHTS

1. A wide operating temperature range ( $-40^{\circ}\text{C}$  to  $+105^{\circ}\text{C}$ ) and highly linear output make the TMP17 an ideal substitute for older, more limited sensor technologies (i.e., thermistors, RTDs, diodes, thermocouples).
2. The TMP17 is electrically rugged; supply irregularities and variations or reverse voltages up to 20 V will not damage the device.
3. Because the TMP17 is a temperature dependent current source, it is immune to voltage noise pickup and IR drops in the signal leads when used remotely.

### FUNCTIONAL BLOCK DIAGRAM

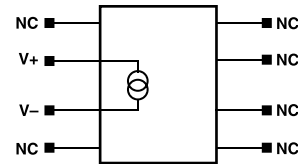

### PACKAGE DIAGRAM SOIC-8

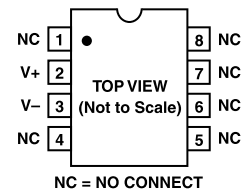

4. The high output impedance of the TMP17 provides greater than  $0.5^{\circ}\text{C}/\text{V}$  rejection of supply voltage drift and ripple.
5. Laser wafer trimming and temperature testing ensures that TMP17 units are easily interchangeable.
6. Initial system accuracy will not degrade significantly over time. The TMP17 has proven long term performance and repeatability advantages inherent in integrated circuit design and construction.

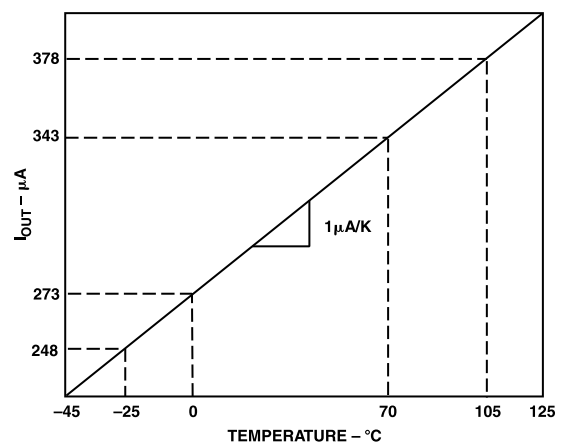

Figure 1. Transfer Characteristic

REV. A

Information furnished by Analog Devices is believed to be accurate and reliable. However, no responsibility is assumed by Analog Devices for its use, nor for any infringements of patents or other rights of third parties that may result from its use. No license is granted by implication or otherwise under any patent or patent rights of Analog Devices. Trademarks and registered trademarks are the property of their respective companies.

# TMP17F/G—SPECIFICATIONS ( $V_S = 5.0\text{ V}$ , $-40^\circ\text{C} \leq T_A \leq 105^\circ\text{C}$ , unless otherwise noted.)

Parameter	Symbol	Conditions	Min	Typ	Max	Unit
ACCURACY						
TMP17F		$T_A = 25^\circ\text{C}^1$			$\pm 2.5$	$^\circ\text{C}$
TMP17G		$T_A = 25^\circ\text{C}^1$			$\pm 3.5$	$^\circ\text{C}$
TMP17F		Over Rated Temperature			$\pm 3.5$	$^\circ\text{C}$
TMP17G		Over Rated Temperature			$\pm 4.5$	$^\circ\text{C}$
POWER SUPPLY REJECTION RATIO						
$4\text{ V} < V_S < 5\text{ V}$	PSRR	Over Rated Temperature <sup>2</sup>			0.5	$^\circ\text{C}/\text{V}$
$5\text{ V} < V_S < 15\text{ V}$	PSRR				0.3	$^\circ\text{C}/\text{V}$
$15\text{ V} < V_S < 30\text{ V}$	PSRR				0.3	$^\circ\text{C}/\text{V}$
Nonlinearity				0.5		$^\circ\text{C}$
OUTPUT						
Nominal Current Output		$T_A = 25^\circ\text{C}$ (298.2 K)		298.2		$\mu\text{A}$
Scale Factor		Over Rated Temperature		1		$\mu\text{A}/^\circ\text{C}$
Repeatability		Note 3		0.2		$^\circ\text{C}$
Long Term Stability		$T_A = 150^\circ\text{C}$ for 500 Hrs <sup>4</sup>		0.2		$^\circ\text{C}/\text{month}$
POWER SUPPLY						
Supply Range	$+V_S$		4		30	V

## NOTES

<sup>1</sup>An external calibration trim can be used to zero the error @  $25^\circ\text{C}$ .

<sup>2</sup>Defined as the maximum deviation from a mathematically best fit line.

<sup>3</sup>Maximum deviation between  $25^\circ\text{C}$  readings after a temperature cycle between  $-40^\circ\text{C}$  and  $+105^\circ\text{C}$ . Errors of this type are noncumulative.

<sup>4</sup>Operation at  $150^\circ\text{C}$ . Errors of this type are noncumulative.

Specifications subject to change without notice.

## ABSOLUTE MAXIMUM RATINGS\*

Maximum Supply Voltage	30 V
Operating Temperature Range	$-40^\circ\text{C}$ to $+105^\circ\text{C}$
Maximum Forward Voltage (1 to 2)	44 V
Maximum Reverse Voltage (2 to 1)	20 V
Dice Junction Temperature	$175^\circ\text{C}$
Storage Temperature Range	$-65^\circ\text{C}$ to $+160^\circ\text{C}$
Lead Temperature (Soldering, 10 sec)	$300^\circ\text{C}$

\*Stresses above those listed under Absolute Maximum Ratings may cause permanent damage to the device. This is a stress rating only and functional operation at or above this specification is not implied. Exposure to the above maximum rating conditions for extended periods may affect device reliability.

## METALLIZATION DIAGRAM

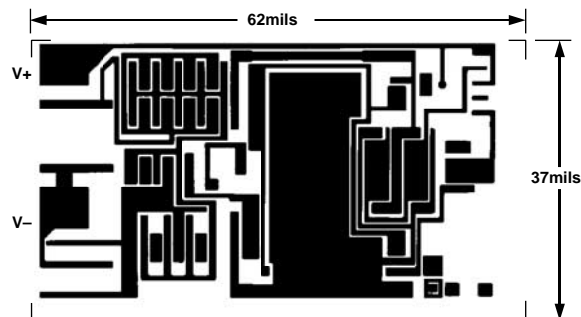

## TEMPERATURE SCALE CONVERSION EQUATIONS

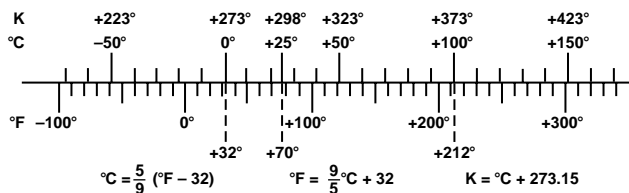

## ORDERING GUIDE

Model	Max Cal Error @ $+25^\circ\text{C}$	Max Error $-40^\circ\text{C}$ to $+105^\circ\text{C}$	Nonlinearity $-40^\circ\text{C}$ to $+105^\circ\text{C}$	Package Option
TMP17FS	2.5 $^\circ\text{C}$	3.5 $^\circ\text{C}$	0.5 $^\circ\text{C}$	R-8
TMP17GS	3.5 $^\circ\text{C}$	4.5 $^\circ\text{C}$	0.5 $^\circ\text{C}$	R-8

## CAUTION

ESD (electrostatic discharge) sensitive device. Electrostatic charges as high as 4000 V readily accumulate on the human body and test equipment and can discharge without detection. Although the TMP17 features proprietary ESD protection circuitry, permanent damage may occur on devices subjected to high energy electrostatic discharges. Therefore, proper ESD precautions are recommended to avoid performance degradation or loss of functionality.



# Typical Performance Characteristics—TMP17

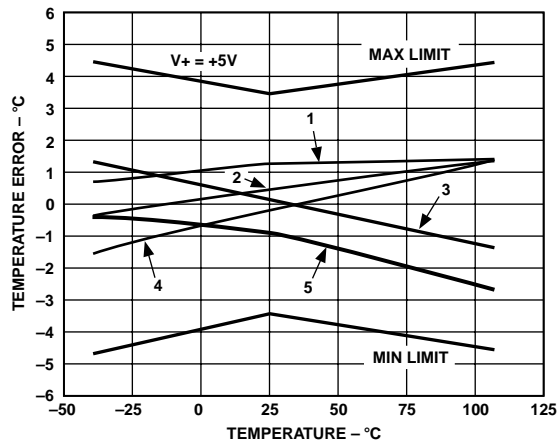

TPC 1. Accuracy vs. Temperature

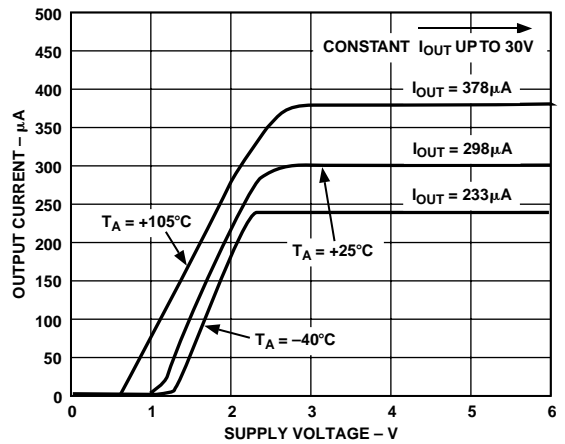

TPC 4. V-I Characteristics

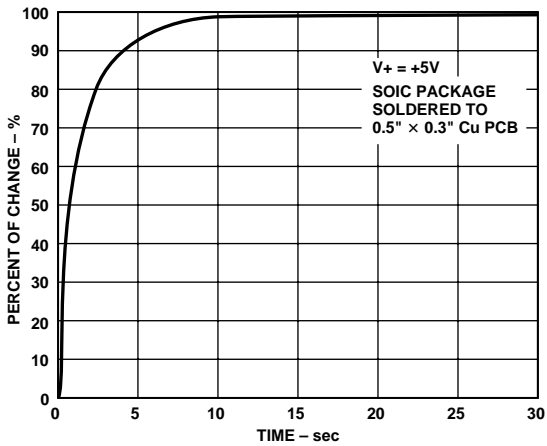

TPC 2. Thermal Response in Stirred Oil Bath

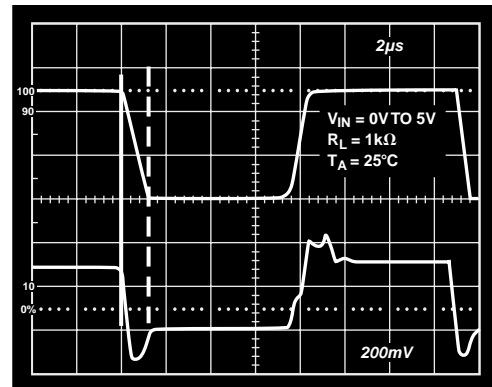

TPC 5. Output Turn-On Settling Time

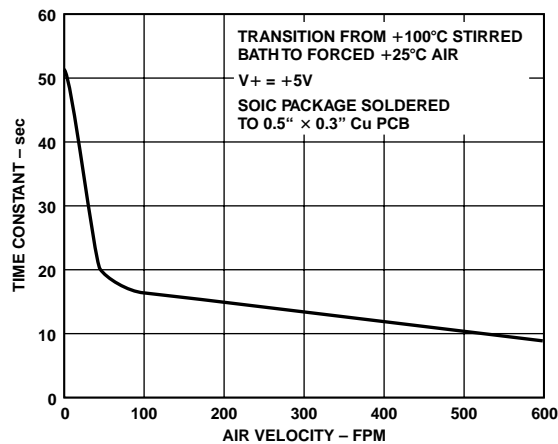

TPC 3. Thermal Time Constant in Forced Air

# TMP17

## THEORY OF OPERATION

The TMP17 uses a fundamental property of silicon transistors to realize its temperature proportional output. If two identical transistors are operated at a constant ratio of collector current densities,  $r$ , then the difference in base-emitter voltages will be  $(kT/q)(\ln r)$ . Since both  $k$ , Boltzmann's constant, and  $q$ , the charge of an electron, are constant, the resulting voltage is directly Proportional to Absolute Temperature (PTAT). In the TMP17, this difference voltage is converted to a PTAT current by low temperature coefficient thin film resistors. This PTAT current is then used to force the total output current to be proportional to degrees Kelvin. The result is a current source with an output equal to a scale factor times the temperature (K) of the sensor. A typical V-I plot of the circuit at 125°C and the temperature extremes is shown in TPC 4.

Factory trimming of the scale factor to 1  $\mu\text{A}/\text{K}$  is accomplished at the wafer level by adjusting the TMP17's temperature reading so it corresponds to the actual temperature. During laser trimming, the IC is at a temperature within a few degrees of 25°C and is powered by a 5 V supply. The device is then packaged and automatically temperature tested to specification.

## FACTORS AFFECTING TMP17 SYSTEM PRECISION

The accuracy limits in the Specifications table make the TMP17 easy to apply in a variety of diverse applications. To calculate a total error budget in a given system, it is important to correctly interpret the accuracy specifications, nonlinearity errors, the response of the circuit to supply voltage variations, and the effect of the surrounding thermal environment. As with other electronic designs, external component selection will have a major effect on accuracy.

## CALIBRATION ERROR, ABSOLUTE ACCURACY, AND NONLINEARITY SPECIFICATIONS

Two primary limits of error are given for the TMP17 such that the correct grade for any given application can easily be chosen for the overall level of accuracy required. They are the calibration accuracy at +25°C and the error over temperature from -40°C to +105°C. These specifications correspond to the actual error the user would see if the current output of a TMP17 were converted to a voltage with a precision resistor. Note that the maximum error at room temperature or over an extended range, including the boiling point of water, can be read directly from the Specifications table. The error limits are a combination of initial error, scale factor variation, and nonlinearity deviation from the ideal 1  $\mu\text{A}/\text{K}$  output. TPC 1 graphically depicts the guaranteed limits of accuracy for a TMP17GS.

The TMP17 has a highly linear output in comparison to older technology sensors (i.e., thermistors, RTDs, and thermocouples), thus a nonlinearity error specification is separated from the absolute accuracy given over temperature. As a maximum deviation from a best-fit straight line, this specification represents the only error that cannot be trimmed out. Figure 2 is a plot of typical TMP17 nonlinearity over the full rated temperature range.

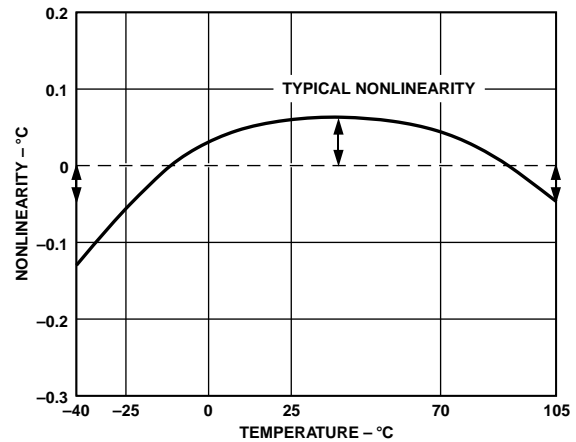

Figure 2. Nonlinearity Error

## TRIMMING FOR HIGHER ACCURACY

Calibration error at 25°C can be removed with a single temperature trim. Figure 3 shows how to adjust the TMP17's scale factor in the basic voltage output circuit.

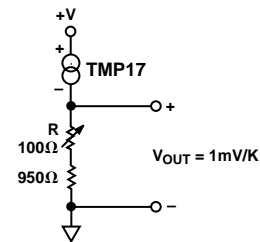

Figure 3. Basic Voltage Output (Single Temperature Trim)

To trim the circuit, the temperature must be measured by a reference sensor and the value of  $R$  should be adjusted so the output ( $V_{OUT}$ ) corresponds to 1 mV/K. Note that the trim procedure should be implemented as close as possible to the temperature for which highest accuracy is desired. In most applications, if a single temperature trim is desired, it can be implemented where the TMP17 current-to-output voltage conversion takes place (e.g., output resistor, offset to an op amp). Figure 4 illustrates the effect on total error when using this technique.

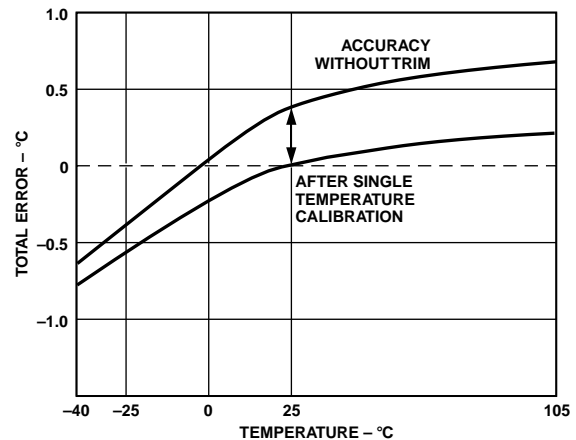

Figure 4. Effect of Scale Factor Trim on Accuracy

If greater accuracy is desired, initial calibration and scale factor errors can be removed by using the TMP17 in the circuit of Figure 5.

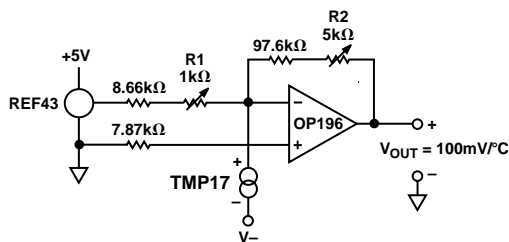

Figure 5. Two Temperature Trim Circuit

With the transducer at 0°C, adjustment of R1 for a 0 V output nulls the initial calibration error and shifts the output from K to °C. Tweaking the gain of the circuit at an elevated temperature by adjusting R2 trims out scale factor error. The only error remaining over the temperature range being trimmed for is nonlinearity. A typical plot of two trim accuracy is given in Figure 6.

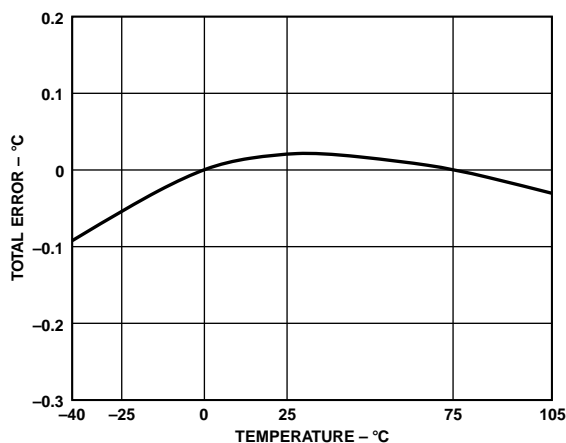

Figure 6. Typical Two Trim Accuracy

## SUPPLY VOLTAGE AND THERMAL ENVIRONMENT EFFECTS

The power supply rejection characteristics of the TMP17 minimize errors due to voltage irregularity, ripple, and noise. If a supply is used other than 5 V (used in factory trimming), the power supply error can be removed with a single temperature trim. The PTAT nature of the TMP17 will remain unchanged. The general insensitivity of the output allows the use of lower cost unregulated supplies and means that a series resistance of several hundred ohms (e.g., CMOS multiplexer, meter coil resistance) will not degrade the overall performance.

The thermal environment in which the TMP17 is used determines two performance traits: the effect of self-heating on accuracy and the response time of the sensor to rapid changes in temperature. In the first case, a rise in the IC junction temperature above the ambient temperature is a function of two variables: the power consumption level of the circuit and the thermal resistance between the chip and the ambient environment ( $\theta_{JA}$ ). Self-heating error in °C can be derived by multiplying the power dissipation by  $\theta_{JA}$ . Because errors of this type can vary widely for surroundings with different heat sinking capacities, it is necessary to specify  $\theta_{JA}$

under several conditions. Table I shows how the magnitude of self-heating error varies relative to the environment. In typical free air applications at 25°C with a 5 V supply, the magnitude of the error is 0.2°C or less. A small glued-on heat sink will reduce the temperature error in high temperature, large supply voltage situations.

Table I. Thermal Characteristics

Medium	$\theta_{JA}$ (°C/W)	$\tau$ (sec)*
Still Air	158	52
Moving Air @ 500 FPM	60	10
Fluorinert Liquid	35	2

\* $\tau$  is an average of one time constant (63.2% of final value). In cases where the thermal response is not a simple exponential function, the actual thermal response may be better than indicated.

Response of the TMP17 output to abrupt changes in ambient temperature can be modeled by a single time constant  $\tau$  exponential function. TPC 2 and TPC 3 show typical response time plots for media of interest.

The time constant,  $\tau$ , is dependent on  $\theta_{JA}$  and on the thermal capacities of the chip and the package. Table I lists the effective  $\tau$  (time to reach 63.2% of the final value) for several different media. Copper printed circuit board connections will sink or conduct heat directly through the TMP17's soldered leads. When faster response is required, a thermally conductive grease or glue between the TMP17 and the surface temperature being measured should be used.

## MOUNTING CONSIDERATIONS

If the TMP17 is thermally attached and properly protected, it can be used in any temperature measuring situation where the maximum range of temperatures encountered is between -40°C and +105°C. Thermally conductive epoxy or glue is recommended under typical mounting conditions. In wet environments, condensation at cold temperatures can cause leakage current related errors and should be avoided by sealing the device in nonconductive epoxy paint or conformal coating.

## APPLICATIONS

Connecting several TMP17 devices in parallel adds the currents through them and produces a reading proportional to the average temperature. TMP17s connected in series will indicate the lowest temperature, because the coldest device limits the series current flowing through the sensors. Both of these circuits are depicted in Figure 7.

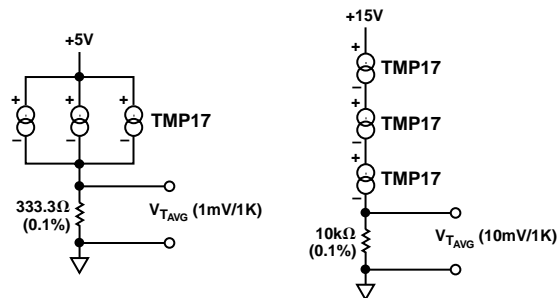

Figure 7. Average and Minimum Temperature Connections

# TMP17

The circuit in Figure 8 demonstrates a method in which a voltage output can be derived in a differential temperature measurement.

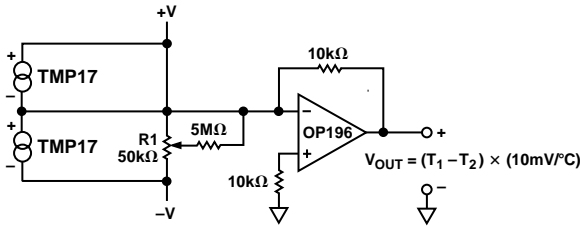

Figure 8. Differential Measurements

R1 can be used to trim out the inherent offset between the two devices. By increasing the gain resistor (10 kΩ), temperature measurements can be made with higher resolution. If the magnitude of V1 and V2 is not the same, the difference in power consumption between the two devices can cause a differential self-heating error.

Cold junction compensation (CJC) used in thermocouple signal conditioning can be implemented using a TMP17 in the circuit configuration of Figure 9. Expensive simulated ice baths or hard to trim, inaccurate bridge circuits are no longer required.

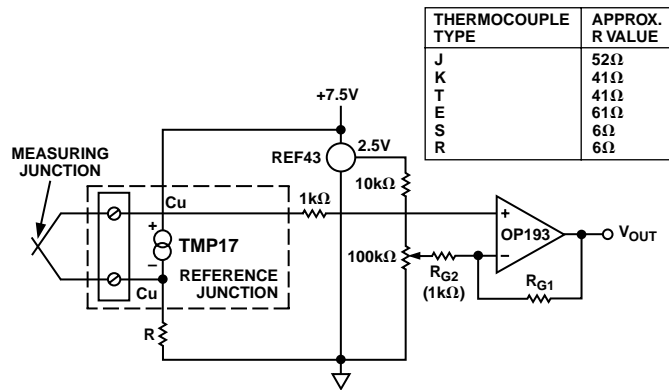

Figure 9. Thermocouple Cold Junction Compensation

The circuit shown can be optimized for any ambient temperature range or thermocouple type by simply selecting the correct value for the scaling resistor R. The TMP17 output (1 μA/K) × R should approximate the line best fit to the thermocouple curve (slope in V/°C) over the most likely ambient temperature range. Additionally, the output sensitivity can be chosen by selecting the resistors R<sub>G1</sub> and R<sub>G2</sub> for the desired noninverting gain. The offset adjustment shown simply references the TMP17 to °C. Note that the TC of the reference and the resistors are the primary contributors to error. Temperature rejection of 40 to 1 can be easily achieved using the above technique.

Although the TMP17 offers a noise immune current output, it is not compatible with process control/industrial automation current loop standards. Figure 10 is an example of a temperature to 4–20 mA transmitter for use with 40 V, 1 kΩ systems.

In this circuit the 1 μA/K output of the TMP17 is amplified to 1 mA/°C and offset so that 4 mA is equivalent to 17°C and 20 mA is equivalent to 33°C. R<sub>T</sub> is trimmed for proper reading at an intermediate reference temperature. With a suitable choice of resistors, any temperature range within the operating limits of the TMP17 may be chosen.

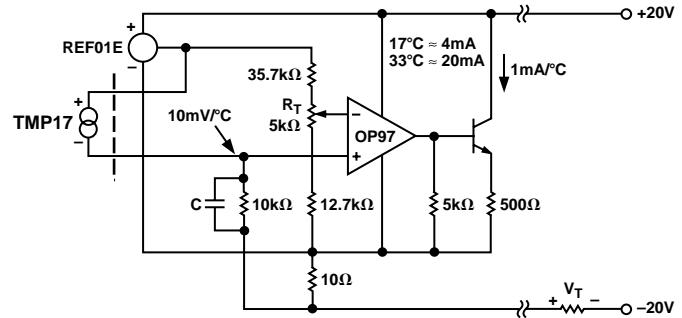

Figure 10. Temperature to 4–20 mA Current Transmitter

Reading temperature with a TMP17 in a microprocessor based system can be implemented with the circuit shown in Figure 11.

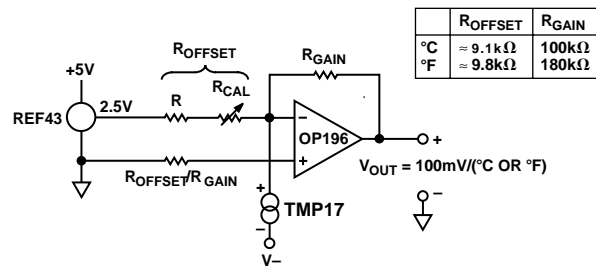

Figure 11. Temperature to Digital Output

By using a differential input A/D converter and choosing the current to voltage conversion resistor correctly, any range of temperatures (up to the 145°C span the TMP17 is rated for) centered at any point can be measured using a minimal number of components. In this configuration, the system will resolve up to 1°C.

A variable temperature controlling thermostat can easily be built using the TMP17 in the circuit in Figure 12.

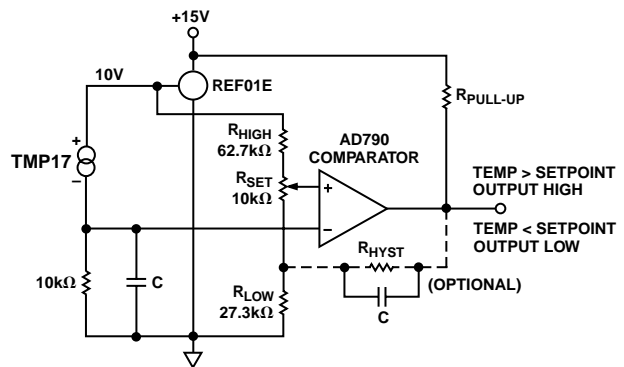

Figure 12. Variable Temperature Thermostat

$R_{HIGH}$  and  $R_{LOW}$  determine the limits of temperature controlled by the potentiometer  $R_{SET}$ . The circuit shown operates over the temperature range  $-25^{\circ}C$  to  $+105^{\circ}C$ . The reference maintains a constant set point voltage and ensures that approximately 7 V appear across the sensor. If it is necessary to guardband for extraneous noise, hysteresis can be added by tying a resistor from the output to the ungrounded end of  $R_{LOW}$ .

Multiple remote temperatures can be measured using several TMP17s with a CMOS multiplexer or a series of 5 V logic gates because of the device's current-mode output and supply-voltage compliance range. The on resistance of a FET switch or output impedance of a gate will not affect the accuracy, as long as 4 V is maintained across the transducer. Muxes and logic driving circuits should be chosen to minimize leakage current related errors. Figure 13 illustrates a locally controlled mux switching the signal current from several remote TMP17s. CMOS or TTL gates can also be used to switch the TMP17 supply voltages, with the multiplexed signal being transmitted over a single twisted pair to the load.

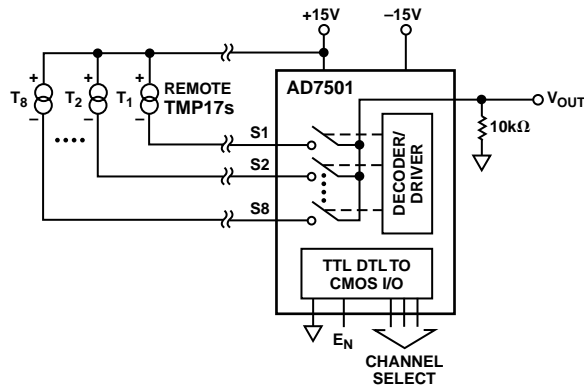

Figure 13. Remote Temperature Multiplexing

To minimize the number of muxes required when a large number of TMP17s are being used, the circuit can be configured in a matrix. That is, a decoder can be used to switch the supply voltage to a column of TMP17s while a mux is used to control which row of sensors is being measured. The maximum number of TMP17s that can be used is the product of the number of channels of the decoder and mux.

An example circuit controlling 80 TMP17s is shown in Figure 14. A 7-bit digital word is all that is required to select one of the sensors. The enable input of the multiplexer turns all the sensors off for minimum dissipation while idling.

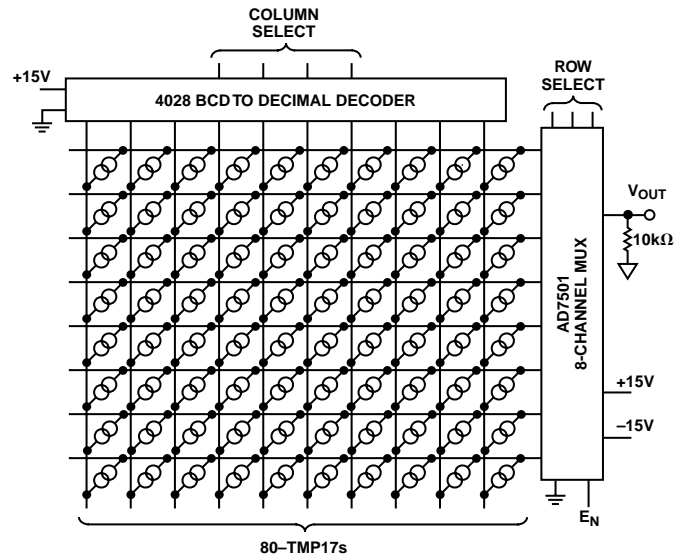

Figure 14. Matrix Multiplexer

To convert the TMP17 output to  $^{\circ}C$  or  $^{\circ}F$ , a single inexpensive reference and op amp can be used as shown in Figure 15. Although this circuit is similar to the two temperature trim circuit shown in Figure 5, there are two important differences. First, the gain resistor is fixed, alleviating the need for an elevated temperature trim. Acceptable accuracy can be achieved by choosing an inexpensive resistor with the correct tolerance. Second, the TMP17 calibration error can be trimmed out at a known convenient temperature (e.g., room temperature) with a single potentiometer adjustment. This step is independent of the gain selection.

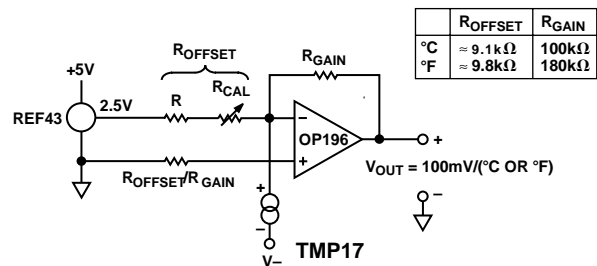
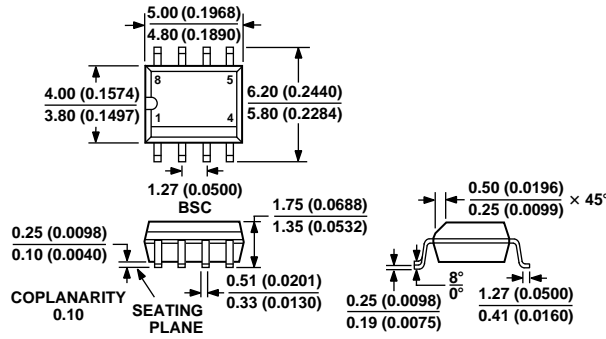

Figure 15. Celsius or Fahrenheit Thermometer

OUTLINE DIMENSIONS

8-Lead Standard Small Outline Package [SOIC]  
Narrow Body  
(R-8)

Dimensions shown in millimeters and (inches)



COMPLIANT TO JEDEC STANDARDS MS-012AA  
CONTROLLING DIMENSIONS ARE IN MILLIMETERS; INCH DIMENSIONS  
(IN PARENTHESES) ARE ROUNDED-OFF MILLIMETER EQUIVALENTS FOR  
REFERENCE ONLY AND ARE NOT APPROPRIATE FOR USE IN DESIGN

Revision History

Location	Page
1/03—Data Sheet changed from REV. 0 to REV. A.	
Deleted Obsolete TPC .....	3
Updated OUTLINE DIMENSIONS .....	8