

OPTION "C"

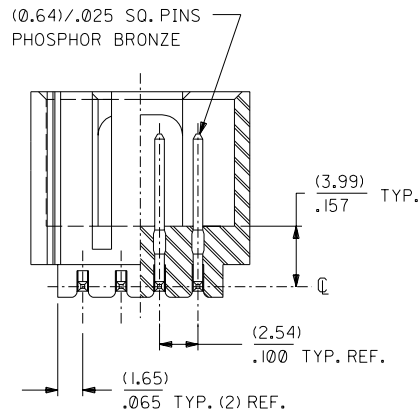

SECTION E-E

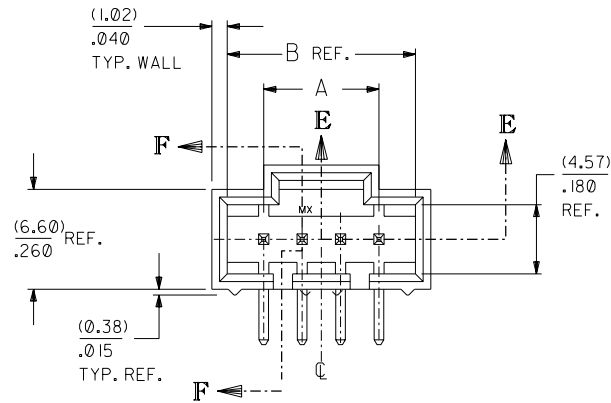
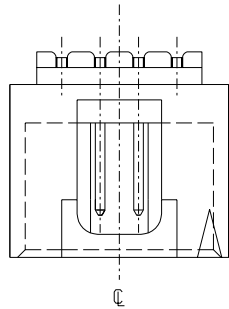
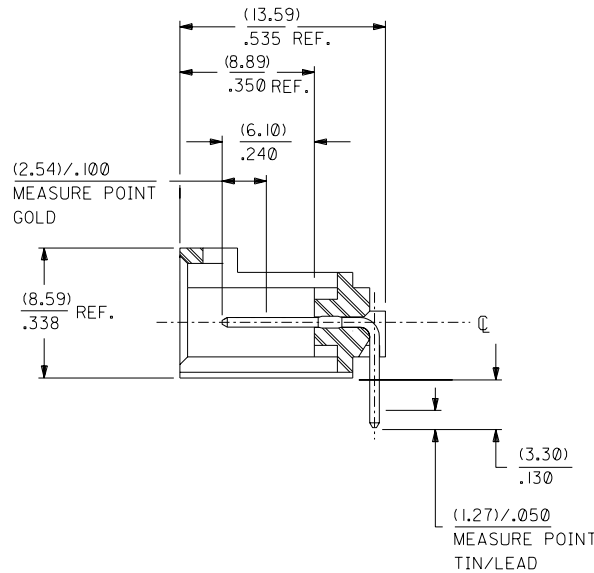

SECTION F-F

NOTES

- 1) MATERIAL: G.F. THERMOPLASTIC, 94V-0, COLOR-BLACK.
- 2) HEADER TO BE USED WITH NO. 70004 INTERIM CLIP, VERSION "A".
- 3) REFER TO PRODUCT SPEC: P.S.-7054I.
- 4) STANDARD PACKAGING PER PK-70873-0017. OPTIONAL PACKAGING MAY BE AVAILABLE. (SEE DRAWING PK-70573-**** FOR ORDER NUMBERS)

- TIN - .000150 MINIMUM TIN PLATE
OVER .000050 MINIMUM NICKEL PLATE.
- 15 GOLD - .000015 MINIMUM GOLD PLATE IN SELECT AREA,
.000075 MINIMUM TIN PLATE IN SELECT AREA,
OVER .000050 MINIMUM NICKEL PLATE OVERALL.
- 30 GOLD - .000030 MINIMUM GOLD PLATE IN SELECT AREA,
.000075 MINIMUM TIN PLATE IN SELECT AREA,
OVER .000050 MINIMUM NICKEL PLATE OVERALL.



RECOMMENDED P.C. BOARD LAYOUT

(FOR USE WITH (1.57) .062 THICK BOARD)

*THE PRIMARY SHIPPING CARTON WILL BE LABELED "COMPLIANT TO ROHS DIRECTIVE 2002/95/EC AND ELV ANNEX II OF DIRECTIVE 2000/53/EC". CARTONS WITHOUT THIS LABEL MAY CONTAIN PRODUCT WITH LEAD. PLATING PER E.S.-88-****

	2	B
	1	B
MFG. SH.		REV.

DIMENSIONS SHOWN (METRIC) INCH UNLESS OTHERWISE SPECIFIED TOLERANCES: ANGULAR ± 1/2°		▽ = 0	▼ = 0	REVISE ONLY ON CAD SYSTEM																
<table border="1"> <tr> <th colspan="2">INCH</th> <th colspan="2">METRIC</th> </tr> <tr> <td>3 PLACE</td> <td>± .010</td> <td>---</td> <td>---</td> </tr> <tr> <td>2 PLACE</td> <td>± .014</td> <td>± 0.25</td> <td>---</td> </tr> <tr> <td>1 PLACE</td> <td>---</td> <td>± 0.35</td> <td>---</td> </tr> </table>		INCH		METRIC		3 PLACE	± .010	---	---	2 PLACE	± .014	± 0.25	---	1 PLACE	---	± 0.35	---	TITLE SALES ASSEMBLY HEADER - RIGHT ANGLE 100 CENTERS		
INCH		METRIC																		
3 PLACE	± .010	---	---																	
2 PLACE	± .014	± 0.25	---																	
1 PLACE	---	± 0.35	---																	
DRAFT WHERE APPLICABLE MUST REMAIN WITHIN DIMENSIONS		SHEET NO. DATE 1 OF 2 05/13/93																		
DRWG. BY: AAB CHK'D. BY: AAB		PART NO. DRWG. NO. SEE CHART SDA-70573-****																		
APP'D. BY: WAZ SCALE: 4 : 1		FILE NAME: 510573X1.DGN THIS DRAWING CONTAINS INFORMATION THAT IS PROPRIETARY TO MOLEX INC. AND SHOULD NOT BE USED WITHOUT WRITTEN PERMISSION.																		
LTR.	REVISIONS	LTR.	REVISIONS	APP'D. BY: DA SIZE: C																

CKT. SIZE	"A"		"B" REF.	
	MM	IN.	MM	IN.
4	7.62	.300	12.45	.490
5	10.16	.400	14.99	.590
6	12.70	.500	17.53	.690
7	15.24	.600	20.07	.790
8	17.78	.700	22.61	.890
9	20.32	.800	25.15	.990
10	22.86	.900	27.69	1.090
11	25.40	1.000	30.23	1.190
12	27.94	1.100	32.77	1.290
13	30.48	1.200	35.31	1.390
14	33.02	1.300	37.85	1.490
15	35.56	1.400	40.39	1.590
16	38.10	1.500	42.93	1.690
17	40.64	1.600	45.47	1.790
18	43.18	1.700	48.01	1.890
19	45.72	1.800	50.55	1.990
20	48.26	1.900	53.09	2.090
21	50.80	2.000	55.63	2.190
22	53.34	2.100	58.17	2.290
23	55.88	2.200	60.71	2.390
24	58.42	2.300	63.25	2.490
25	60.96	2.400	65.79	2.590

	13	12	11	10	9	8	7	6	5	4	3	2	1
	ENGINEERING NUMBER A-70573-	MANUFACTURE RELEASE STATUS								CONNECTOR END PLATING	P.C. BOARD END PLATING		
J										TYPE	H MEAS.	TYPE	K MEAS.
	-0003-0024	R.F.M.								15 GOLD	(2,54) .100	TIN	(1,27) .050
	-0038-0059	R.F.M.								TIN	(2,54) .100	TIN	(1,27) .050
I	-0073-0094												
	-0108-0129	R.F.M.								30 GOLD	(2,54) .100	TIN	(1,27) .050
H													

G	CKTS	EDP NUMBER	ENG NUMBER	EDP NUMBER	ENG NUMBER	EDP NUMBER	ENG NUMBER	EDP NUMBER	ENG NUMBER	EDP NUMBER	ENG NUMBER	EDP NUMBER	ENG NUMBER	EDP NUMBER	ENG NUMBER	CKTS
	02	N.A.	N.A.	N.A.	N.A.	N.A.	N.A.	N.A.	N.A.							02
	03	N.A.	N.A.	N.A.	N.A.	N.A.	N.A.	N.A.	N.A.							03
	04	705-73-0003	A-70573-0003	705-73-0038	A-70573-0038			705-73-0108	A-70573-0108							04
	05	705-73-0004	A-70573-0004	705-73-0039	A-70573-0039			705-73-0109	A-70573-0109							05
	06	705-73-0005	A-70573-0005	705-73-0040	A-70573-0040			705-73-0110	A-70573-0110							06
F	07	705-73-0006	A-70573-0006	705-73-0041	A-70573-0041			705-73-0111	A-70573-0111							07
	08	705-73-0007	A-70573-0007	705-73-0042	A-70573-0042			705-73-0112	A-70573-0112							08
	09	705-73-0008	A-70573-0008	705-73-0043	A-70573-0043			705-73-0113	A-70573-0113							09
	10	705-73-0009	A-70573-0009	705-73-0044	A-70573-0044			705-73-0114	A-70573-0114							10
	11	705-73-0010	A-70573-0010	705-73-0045	A-70573-0045			705-73-0115	A-70573-0115							11
	12	705-73-0011	A-70573-0011	705-73-0046	A-70573-0046			705-73-0116	A-70573-0116							12
E	13	705-73-0012	A-70573-0012	705-73-0047	A-70573-0047			705-73-0117	A-70573-0117							13
	14	705-73-0013	A-70573-0013	705-73-0048	A-70573-0048			705-73-0118	A-70573-0118							14
	15	705-73-0014	A-70573-0014	705-73-0049	A-70573-0049			705-73-0119	A-70573-0119							15
	16	705-73-0015	A-70573-0015	705-73-0050	A-70573-0050			705-73-0120	A-70573-0120							16
	17	705-73-0016	A-70573-0016	705-73-0051	A-70573-0051			705-73-0121	A-70573-0121							17
	18	705-73-0017	A-70573-0017	705-73-0052	A-70573-0052			705-73-0122	A-70573-0122							18
	19	705-73-0018	A-70573-0018	705-73-0053	A-70573-0053			705-73-0123	A-70573-0123							19
D	20	705-73-0019	A-70573-0019	705-73-0054	A-70573-0054			705-73-0124	A-70573-0124							20
	21	705-73-0020	A-70573-0020	705-73-0055	A-70573-0055			705-73-0125	A-70573-0125							21
	22	705-73-0021	A-70573-0021	705-73-0056	A-70573-0056			705-73-0126	A-70573-0126							22
	23	705-73-0022	A-70573-0022	705-73-0057	A-70573-0057			705-73-0127	A-70573-0127							23
	24	705-73-0023	A-70573-0023	705-73-0058	A-70573-0058			705-73-0128	A-70573-0128							24
	25	705-73-0024	A-70573-0024	705-73-0059	A-70573-0059			705-73-0129	A-70573-0129							25

C															C
B															B

										DIMENSIONS SHOWN (METRIC) INCH UNLESS OTHERWISE SPECIFIED TOLERANCES: ANGULAR ± 1/2°		▽ = 0 ▼ = 0 REVISE ONLY ON CAD SYSTEM	
										INCH METRIC		TITLE	
										3 PLACE ± --- ---		SALES ASSEMBLY HEADER - RIGHT ANGLE .100 CENTERS	
										2 PLACE ± --- ± ---		MOLEX INCORPORATED SHEET NO. DATE	
										1 PLACE --- ± ---		L15LE,ILL. U.S.A. 60532 2 05/13/93	
										DRAFT WHERE APPLICABLE MUST REMAIN WITHIN DIMENSIONS		PART NO. DRWG. NO.	
										SEE SHEET 1		SEE CHART SDA-70573-****	
										DRWG. BY AAB CHK'D. BY AAB		FILE NAME DIV. SIZE	
										APP'D. BY WAZ SCALE :		ST0573X2 THIS DRAWING CONTAINS INFORMATION THAT IS PROPRIETARY TO MOLEX INC. AND SHOULD NOT BE USED WITHOUT WRITTEN PERMISSION. DA C	
										LTR. REVISIONS		LTR. REVISIONS	

	13	12	11	10	9	8	7	6	5	4	3	2	1
--	----	----	----	----	---	---	---	---	---	---	---	---	---