

Data Sheet

SMT-1341-T-HT-R

PUI Audio's **High-Temp** line of products is designed to meet and exceed the needs of the automotive industry with ultra-wide operating temperatures. The **SMT-1341-T-HT-R** is designed for high output at 2 kHz in a small package.

- Wide -40°C to +105°C operating temperature
- ≥85 dB output at 10cm with 5 Vp-p input
- Weighs only 0.5 grams

Transducer Specifications

Parameters	Values	Units
Rated Voltage	5	Vp-p
Operating Voltage Range	1-25	Vp-p
Current Draw at Rated Voltage	≤5	mA
Capacitance at 100Hz	15000±30%	pF
Minimum SPL @ 10cm	≥85	dBA
Resonant Frequency	4100±500	Hz
Housing Material	LCP	-
Weight	0.5	Grams
Acceptable Soldering Methods	Hand Solder, Reflow Solder	See page 2 for soldering information
Environmental Compliances	RoHS	-
Storage Temperature	-40 ~ +120	°C
Operating Temperature	-40 ~ +105	°C

Measurement Method (5 Vp-p, 4100Hz, 50% duty cycle square wave with SPL meter spaced at 10cm)

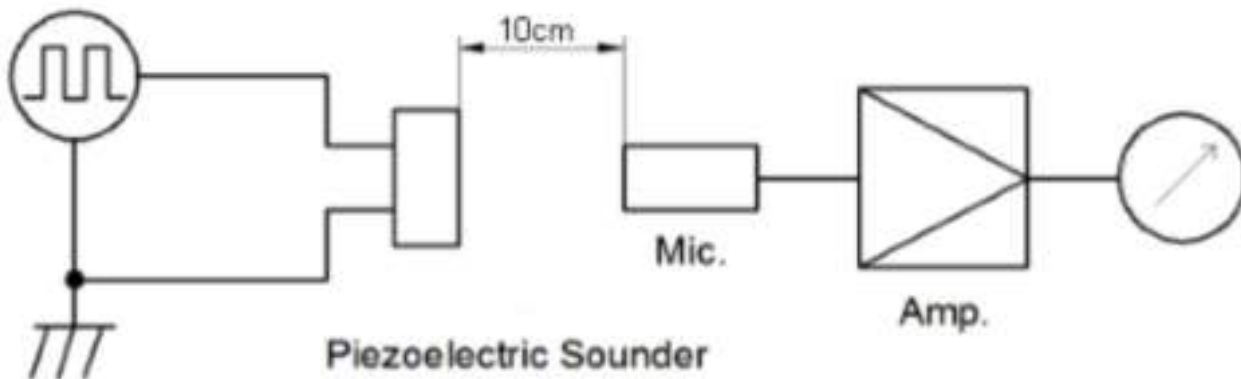

Typical Frequency Response (5 Vp-p sine-sweep with microphone spaced at 10cm)

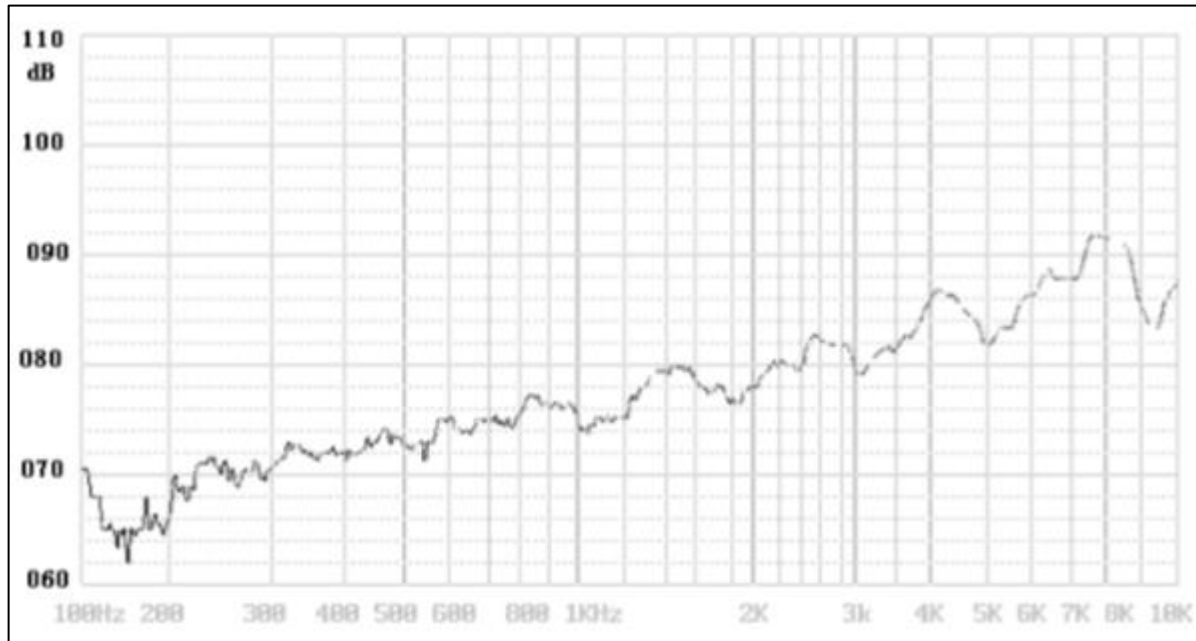

Recommended Soldering Procedure

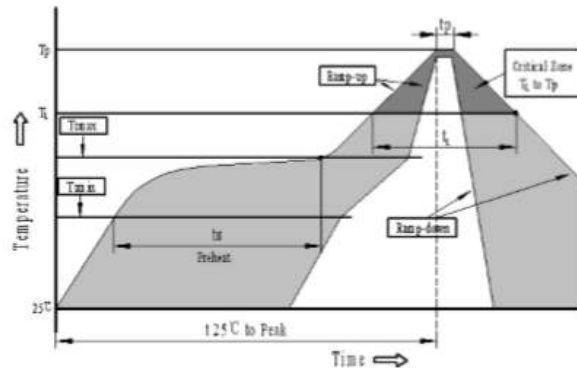

Profile Feature	Pb-Free Assembly
Average ramp-up rate(T_L to T_p)	3°C/second max.
Preheat	
-Temperature Min.(T_{Smin})	150°C
-Temperature Min.(T_{Smax})	200°C
-Temperature Min.(t_s)	60~180 seconds
T_{Smax} to T_L	
-Ramp-up Rate	3°C/second max.
Time maintained above:	
- Temperature(T_L)	217°C
-Time(T_L)	60~150 seconds
Peak temperature(T_p)	245°C+0/-5°C
Time within 5°C of actual Peak temperature (t_p)	6 seconds max.
Ramp-down Rate	6°C/second max.
Time 25°C to Peak Temperature	8 minutes max.
We suggest the customer do the reflow soldering once.	

Reliability Testing

Type of Test	Test Specifications
High Temperature Test	Test part at +120°C for 120 hours
Low Temperature Test	Test part at -40°C for 120 hours
Humidity Test	40±2°C, 90~95% RH, 120 hours
Temperature Cycle Testing	Total 5 cycles, 1 cycle consisting of -40±2°C, 30 minutes 20±5°C 15 minutes 120±2°C, 30 minutes 20±5°C 15 minutes
Vibration Test	Sweep from 10 to 55 Hz and then 55 to 10 under single amplitude of 1.0mm in 1 minute. The vibration test shall consist of 2 hours per plane in each three mutually perpendicular planes for a total time of 6 hours
Shock Test	Sounder shall be measured after being applied shock (980m/s ²) for each three mutually perpendicular directions to each of 3 times by half sine wave.
Drop Test	Dropped naturally from 70cm height onto the surface of 10mm thick wooden board. 2 directions-upper and side of the part are to be applied.

After being placed for 2 to 4 hours at room temperature, the product shall meet specifications, except the SPL should be in ±10dB compared with initial one

Dimensions (Tolerance: ±0.5mm unless otherwise specified)

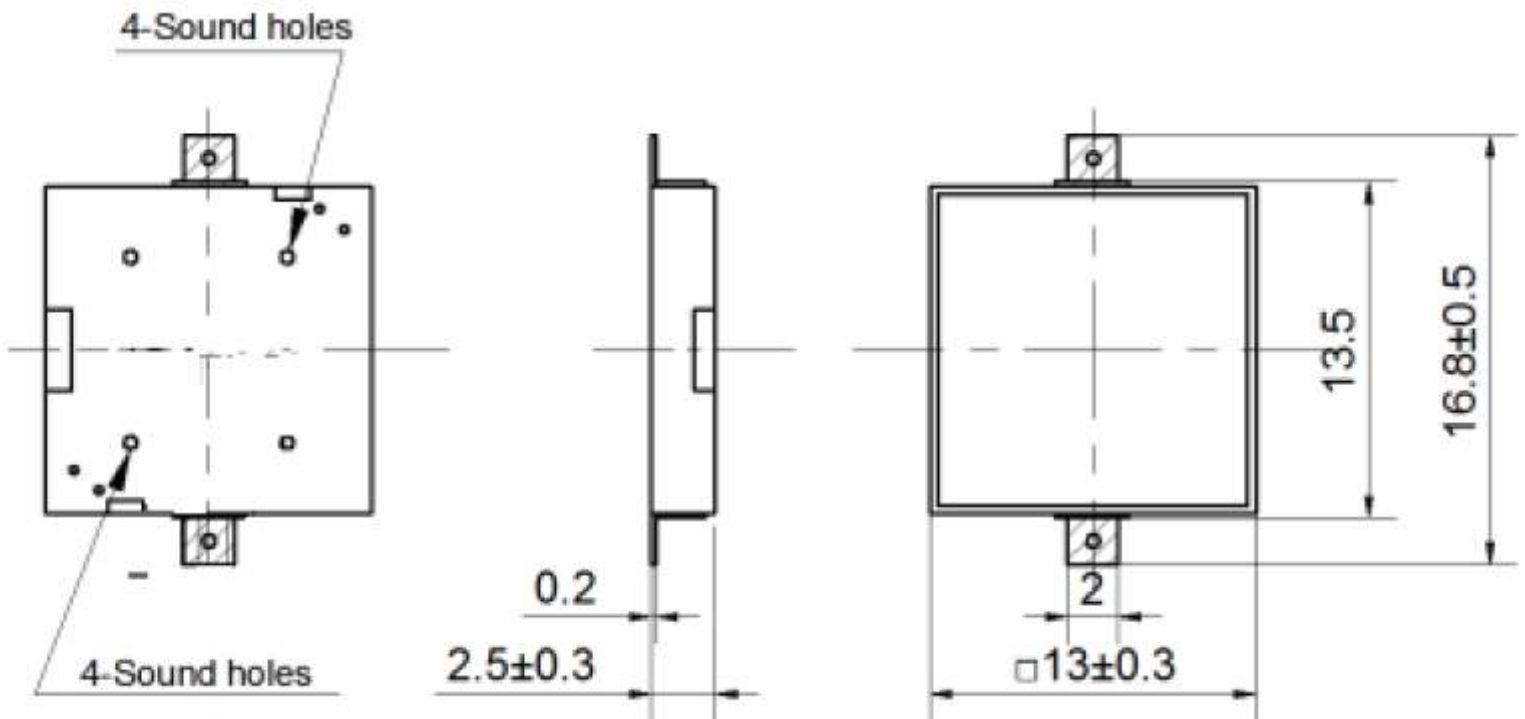

Suggested Land Pattern*

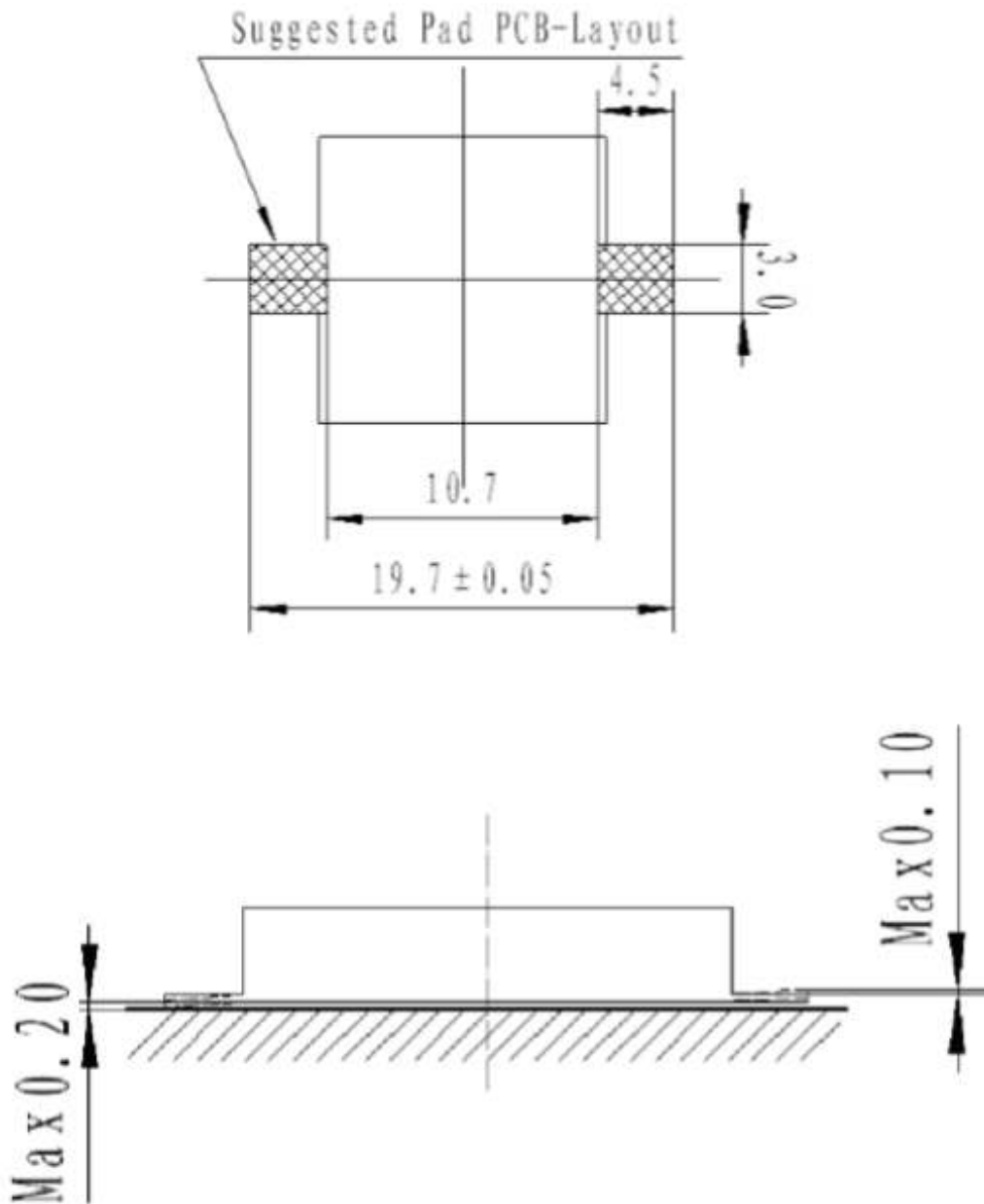

*This land pattern is advisory only and its use or adaptation is entirely voluntary. PUI Audio disclaims all liability of any kind associated with the use, application, or adaptation of this land pattern.

Packaging

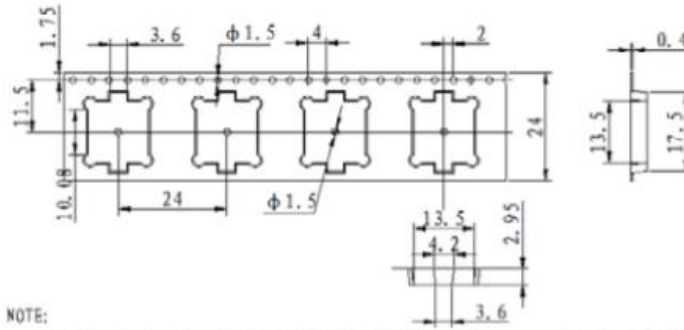

NOTE:

1. 10 sprocket hole pitch cumulative tolerance $\pm 0.20\text{mm}$.
2. All dimensions meet EIA-481-D requirements.
3. Thickness: $0.4 \pm 0.05\text{mm}$.
4. Component loaded per 13" reel: 900pcs.

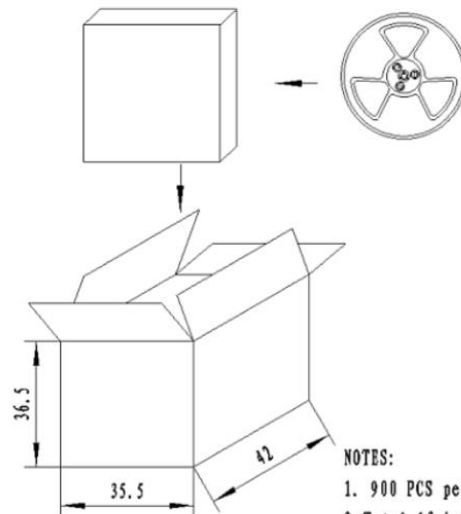
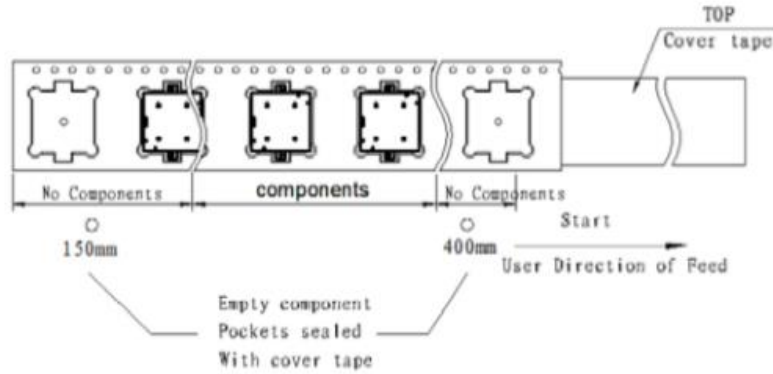

NOTES:

1. 900 PCS per box
2. Total 10 boxes per carton
3. Total 9000 PCS carton
4. volume: $42 \times 35.5 \times 36.5\text{cm}$

Specifications Revisions

Revision	Description	Date
-	Released from Engineering	3/6/2020

Note:

1. Unless otherwise specified:
 - A. All dimensions are in millimeters.
 - B. Default tolerances are $\pm 0.5\text{mm}$ and angles are $\pm 3^\circ$.
2. Specifications subject to change or withdrawal without notice.