

Type OTB DC/AC Dual Rated Capacitors

Protected, High Voltage, Paper-Film/Foil Capacitors for AC & DC Applications



Type OTB is a capacitor with a robust construction consisting of a paper or a combination of paper and film dielectric system with foil electrodes, and is protected by a pressure sensitive interrupter. The OTB may be used for all normal DC blocking, filtering and bypass applications as well as AC motor-run and other 60 Hz applications. Type OTB is supplied in an oval metal case with easy to use solder lug terminals positioned in plastic insulator cups.

Highlights

- Protected: Pressure sensitive interrupter
- Good for DC and 60 Hz AC applications

Specifications

Capacitance Range	0.1 μ F to 35.0 μ F
Capacitance Tolerance	$\pm 10\%$
Rated Voltage	400 Vdc / 236 Vac 600 Vdc / 330 Vac 1000 Vdc / 440 Vac 1500 Vdc / 660 Vac 2000 Vdc / 700 Vac 2500 Vdc / 800 Vac 3000 Vdc / 950 Vac
Operating Temperature Range	-55 °C to +85 °C
Service Life Objective	The service life objective for this series is 60,000 hours of operating life with a 90% survival rate when operated at full voltage and at rated ambient temperature. Capacitors are frequently used at voltages and ambient temperatures other than rated conditions. Service life may be estimated under specific conditions of temperature and voltage by contacting CDE engineering.
Regulatory Information	

Outline Drawing

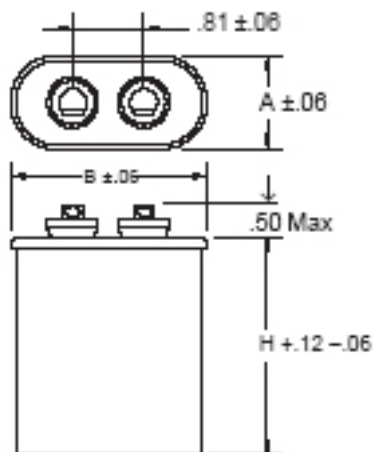

Mounting Brackets

Case Code	Dimensions (inches)		Brackets	
	A	B	Universal	Wrap Around
A	1.31	2.16	32107-1	30393-5 or OB2
C	1.91	2.91	32107-2	30393-9 or OB4
D	1.97	3.66	32107-3	OB3

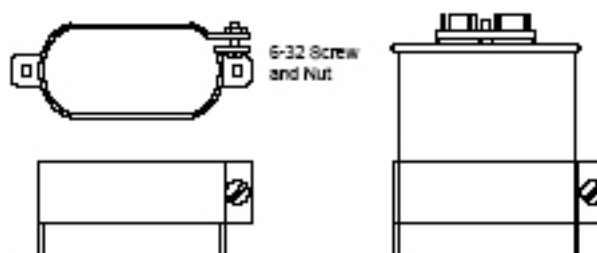

Type OTB DC/AC Dual Rated Capacitors

Ratings

Cap (µF)	Catalog Part Number	A (Inches)	B (Inches)	H (Inches)
400 Vdc (236 Vac) - Paper Dielectric				
3.0	OTBE305KNPIR-F	1.31	2.16	2.13
4.0	OTBE405KNPIR-F	1.31	2.16	2.38
5.0	OTBE505KNPIR-F	1.31	2.16	2.63
6.0	OTBE605KNPIR-F	1.31	2.16	2.88
8.0	OTBE805KNPIR-F	1.31	2.16	3.88
10.0	OTBE106KNPIR-F	1.31	2.16	4.75
12.0	OTBE126KNPIR-F	1.91	2.91	3.13
15.0	OTBE156KNPIR-F	1.91	2.91	3.50
20.0	OTBE206KNPIR-F	1.91	2.91	4.75
25.0	OTBE256KNPIR-F	1.91	2.91	5.75
30.0	OTBE306KNPIR-F	1.91	2.91	6.75
600 Vdc (330 Vac) - Paper Dielectric				
.50	OTBF504KNPIR-F	1.31	2.16	2.13
1.0	OTBF105KNPIR-F	1.31	2.16	2.13
2.0	OTBF205KNPIR-F	1.31	2.16	2.13
3.0	OTBF305KNPIR-F	1.31	2.16	2.38
4.0	OTBF405KNPIR-F	1.31	2.16	2.63
5.0	OTBF505KNPIR-F	1.31	2.16	3.13
6.0	OTBF605KNPIR-F	1.31	2.16	3.88
8.0	OTBF805KNPIR-F	1.31	2.16	4.75
10.0	OTBF106KNPIR-F	1.91	2.91	3.13
12.0	OTBF126KNPIR-F	1.91	2.91	3.88
15.0	OTBF156KNPIR-F	1.91	2.91	4.25
20.0	OTBF206KNPIR-F	1.91	2.91	5.75
25.0	OTBF256KNPIR-F	1.91	2.91	6.75
30.0	OTBF306KNPIR-F	1.97	3.66	6.25
35.0	OTBF356KNPIR-F	1.97	3.66	7.25
1000 Vdc (440 Vac) - Paper Dielectric				
.10	OTBG104KNPIR-F	1.31	2.16	2.13
.25	OTBG254KNPIR-F	1.31	2.16	2.13
.50	OTBG504KNPIR-F	1.31	2.16	2.13
1.0	OTBG105KNPIR-F	1.31	2.16	2.13
2.0	OTBG205KNPIR-F	1.31	2.16	2.63
3.0	OTBG305KNPIR-F	1.31	2.16	3.13
4.0	OTBG405KNPIR-F	1.31	2.16	4.25
5.0	OTBG505KNPIR-F	1.31	2.16	4.75
6.0	OTBG605KNPIR-F	1.91	2.91	3.13
8.0	OTBG805KNPIR-F	1.91	2.91	4.25
10.0	OTBG106KNPIR-F	1.91	2.91	4.75
12.0	OTBG126KNPIR-F	1.91	2.91	5.75
15.0	OTBG156KNPIR-F	1.91	2.91	7.25
20.0	OTBG206KNPIR-F	1.97	3.66	7.25
25.0	OTBG256KNPIR-F	1.97	3.66	9.00

Cap (µF)	Catalog Part Number	A (Inches)	B (Inches)	H (Inches)
1500 Vdc (660 Vac) - Film/Paper Dielectric				
.50	OTBH504KNPIR-F	1.31	2.16	2.13
1.0	OTBH105KNPIR-F	1.31	2.16	2.13
2.0	OTBH205KNPIR-F	1.31	2.16	3.13
3.0	OTBH305KNPIR-F	1.31	2.16	4.25
4.0	OTBH405KNPIR-F	1.91	2.91	3.13
5.0	OTBH505KNPIR-F	1.91	2.91	3.50
6.0	OTBH605KNPIR-F	1.91	2.91	4.25
8.0	OTBH805KNPIR-F	1.91	2.91	5.25
10.0	OTBH106KNPIR-F	1.97	3.66	5.25
12.0	OTBH126KNPIR-F	1.97	3.66	5.75
15.0	OTBH156KNPIR-F	1.97	3.66	6.75
2000 Vdc (700 Vac) - Film/Paper Dielectric				
.10	OTBJ104KNPIR-F	1.31	2.16	2.13
.25	OTBJ254KNPIR-F	1.31	2.16	2.13
.50	OTBJ504KNPIR-F	1.31	2.16	2.13
1.0	OTBJ105KNPIR-F	1.31	2.16	2.63
2.0	OTBJ205KNPIR-F	1.31	2.16	4.25
3.0	OTBJ305KNPIR-F	1.91	2.91	3.50
4.0	OTBJ405KNPIR-F	1.91	2.91	4.25
5.0	OTBJ505KNPIR-F	1.91	2.91	4.75
6.0	OTBJ605KNPIR-F	1.91	2.91	5.75
8.0	OTBJ805KNPIR-F	1.97	3.66	5.75
10.0	OTBJ106KNPIR-F	1.97	3.66	6.75
2500 Vdc (800 Vac) - Film/Paper Dielectric				
.50	OTBK504KNPIR-F	1.31	2.16	2.13
1.0	OTBK105KNPIR-F	1.91	2.91	2.88
2.0	OTBK205KNPIR-F	1.91	2.91	3.13
3.0	OTBK305KNPIR-F	1.91	2.91	4.25
4.0	OTBK405KNPIR-F	1.91	2.91	5.75
5.0	OTBK505KNPIR-F	1.91	2.91	6.75
6.0	OTBK605KNPIR-F	1.97	3.66	5.75
7.0	OTBK705KNPIR-F	1.97	3.66	6.75
8.0	OTBK805KNPIR-F	1.97	3.66	7.25
3000 Vdc (950 Vac) - Film/Paper Dielectric				
.10	OTBL104KNPIR-F	1.31	2.16	2.13
.25	OTBL254KNPIR-F	1.31	2.16	2.13
.50	OTBL504KNPIR-F	1.91	2.91	2.88
1.0	OTBL105KNPIR-F	1.91	2.91	2.88
2.0	OTBL205KNPIR-F	1.91	2.91	4.25
3.0	OTBL305KNPIR-F	1.91	2.91	5.75
4.0	OTBL405KNPIR-F	1.97	3.66	5.75
5.0	OTBL505KNPIR-F	1.97	3.66	6.75

Type OTB DC/AC Dual Rated Capacitors

Notice and Disclaimer: All product drawings, descriptions, specifications, statements, information and data (collectively, the "Information") in this datasheet or other publication are subject to change. The customer is responsible for checking, confirming and verifying the extent to which the Information contained in this datasheet or other publication is applicable to an order at the time the order is placed. All Information given herein is believed to be accurate and reliable, but it is presented without any guarantee, warranty, representation or responsibility of any kind, expressed or implied. Statements of suitability for certain applications are based on the knowledge that the Cornell Dubilier company providing such statements ("Cornell Dubilier") has of operating conditions that such Cornell Dubilier company regards as typical for such applications, but are not intended to constitute any guarantee, warranty or representation regarding any such matter – and Cornell Dubilier specifically and expressly disclaims any guarantee, warranty or representation concerning the suitability for a specific customer application, use, storage, transportation, or operating environment. The Information is intended for use only by customers who have the requisite experience and capability to determine the correct products for their application. Any technical advice inferred from this Information or otherwise provided by Cornell Dubilier with reference to the use of any Cornell Dubilier products is given gratis (unless otherwise specified by Cornell Dubilier), and Cornell Dubilier assumes no obligation or liability for the advice given or results obtained. Although Cornell Dubilier strives to apply the most stringent quality and safety standards regarding the design and manufacturing of its products, in light of the current state of the art, isolated component failures may still occur. Accordingly, customer applications which require a high degree of reliability or safety should employ suitable designs or other safeguards (such as installation of protective circuitry or redundancies or other appropriate protective measures) in order to ensure that the failure of an electrical component does not result in a risk of personal injury or property damage. Although all product-related warnings, cautions and notes must be observed, the customer should not assume that all safety measures are indicated in such warnings, cautions and notes, or that other safety measures may not be required.