

REVISIONS			
REV	DESCRIPTION, ECN, EAR NO.	DATE	APP'D
D	UPDATE LAYOUT & ADD PACKAGE SPEC	DEC04/20	K.T
E	UPDATE PANEL CUT OUT DIMENSION	DEC25/20	K.T
F	UPDATE VOLTAGE	JUN15/21	K.T

NOTES:

- ELECTRICAL:**
- 60 VDC WITH MAXIMUM POWER 100 W
 - INSULATING RESISTANCE : 500 MEGAOHMS MINIMUM.
 - DIELECTRIC STRENGTH : 1000 VAC 60Hz, 1MIN.
 - CATEGORY 5e CHARACTERISTIC

FREQUENCY MHZ	NEAR-END CROSSTALK dB, MIN.	RETURN LOSS dB, MIN.	INSERTION LOSS dB, MAX.
1.0	65.0	30.0	0.1
4.0	65.0	30.0	0.1
8.0	64.9	30.0	0.1
10.0	63.0	30.0	0.1
16.0	58.9	30.0	0.2
20.0	57.0	30.0	0.2
25.0	55.0	30.0	0.2
31.25	53.1	30.0	0.2
62.5	47.1	24.1	0.3
100.0	43.0	20.0	0.4

MECHANICAL:

- SHIELD: STAINLESS STEEL WITH 100u" MATTE TIN OVER 20u" MIN. NICKEL UNDERPLATE
- HOUSING: HIGH TEMP THERMOPLASTIC. UL 94V-0.
- CONTACT: PHOSPHOR BRONZE
SELECTIVE GOLD PLATING FOR MATING SURFACE,
50u" MIN. NICKEL UNDERPLATE
100u" MATTE TIN PLATING ON CONTACT SOLDER TAIL
- COPLANARITY:
THE MAXIMUM GAP BETWEEN ALL TERMINAL TAILS IS 0.10 [0.004]

ENVIRONMENTAL:

- STORAGE: -40 °C TO +85 °C
- OPERATION: -55 °C TO +85 °C
- MATES WITH MODULAR PLUG CONFORMING TO TIA 1096 STANDARD.
- RECOMMENDED SOLDER PROCESS:
REFLOW SOLDER, PEAK TEMPERATURE 260°C FOR 10 SECONDS MAX.

RJ CONNECTOR CONFORMS TIA-1096 STANDARD

AMPHENOL PART NUMBER DESCRIPTION: RJE3A-188-1X01

GOLD PLATING OPTION
1=6u" GOLD PLATING
2=15u" MIN GOLD PLATING
3=30u" MIN GOLD PLATING
4=50u" MIN GOLD PLATING

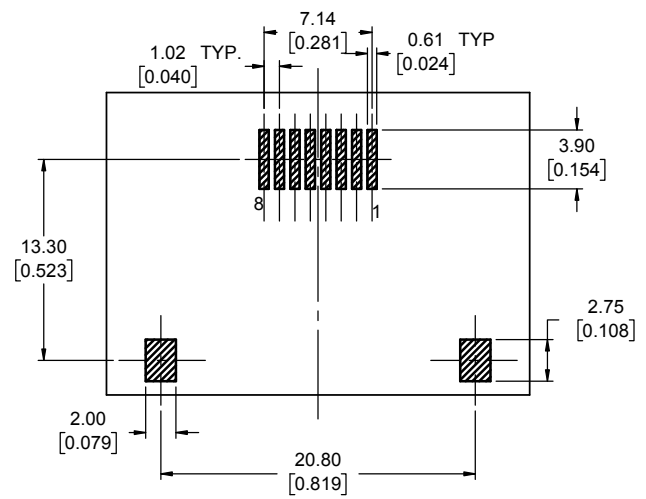
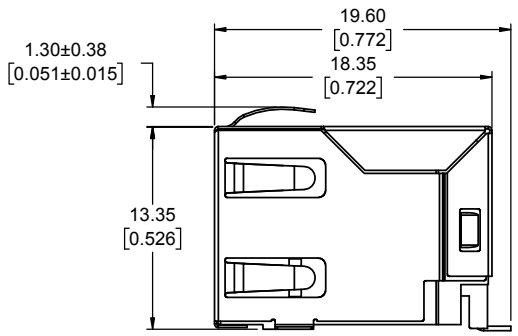
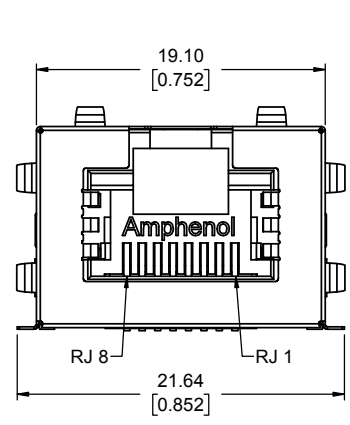
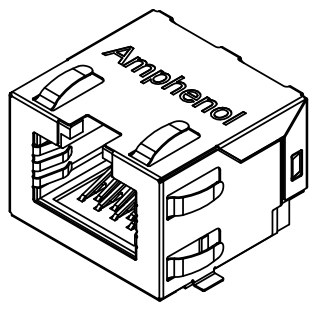
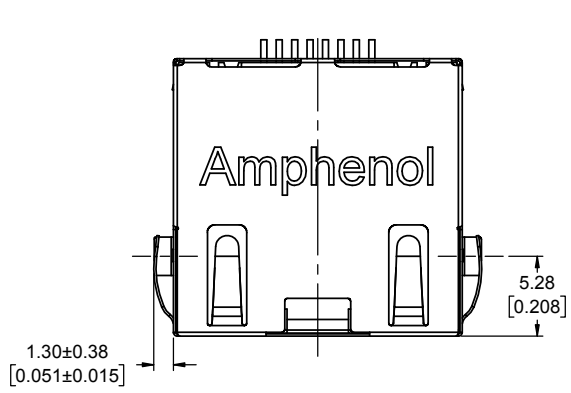

RECOMMENDED PCB LAYOUT
VIEW FROM COMPONENT SIDE
TOLERANCE: +/-0.05[0.002]

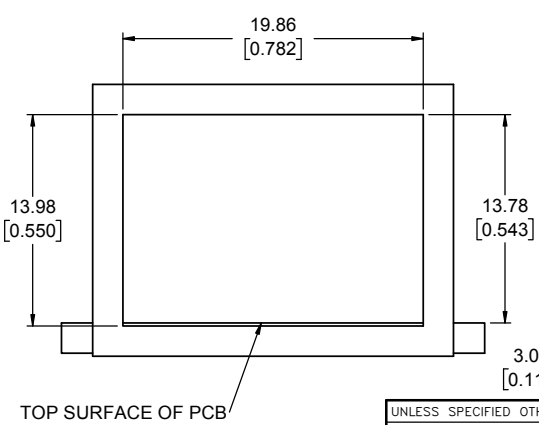

TOP SURFACE OF PCB

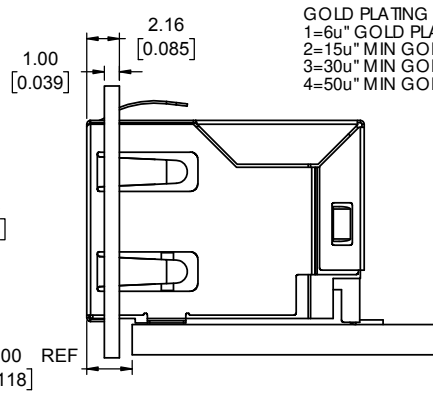

UNLESS SPECIFIED OTHERWISE	DRAWN	JAMISON.C	AUG16/19
PRIMARY UNITS MILLIMETERS	CHECKED	L.CHAN	AUG16/19
SECONDARY INCHES	M.E. APP'D		
REFERENCE IN PARENTHESES	Q.A. APP'D		
GENERAL TOLERANCES	DWG APPR.	A.GREEN	AUG16/19
1 DECIMAL PLACE ±0.38	ENG. REL. NO.		
2 DECIMAL PLACES ±0.25	REF.		
3 DECIMAL PLACES ±0.13	THIRD ANGLE PROJECTION		
ANGULAR DEGREES ±1°	DO NOT SCALE DRAWING		

Amphenol Canada Corp.
Commercial Products

MODULAR JACK, SINGLE PORT, 8P8C,
SHIELDED, TAB UP, WITHOUT LED,
CAT 5e---RoHS COMPLIANT

DWG. NO. **P-RJE3A-188-1X01** REV **F**

CODE ID NO. 03554 | DWG SIZE: N/A | SCALE: FIT | SHEET 1 OF 2

REVISIONS			
REV	DESCRIPTION, ECN, EAR NO.	DATE	APP'D
D	UPDATE LAYOUT & ADD PACKAGE SPEC	DEC04/20	K.T
E	UPDATE PANEL CUT OUT DIMENSION	DEC25/20	K.T
F	UPDATE VOLTAGE	JUN15/21	K.T

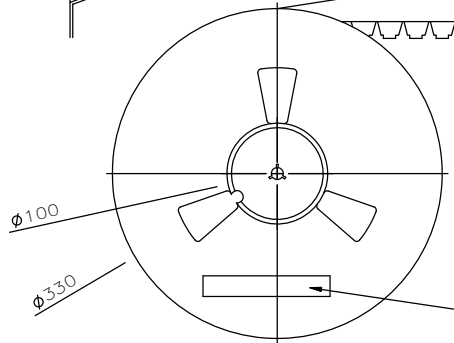
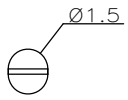
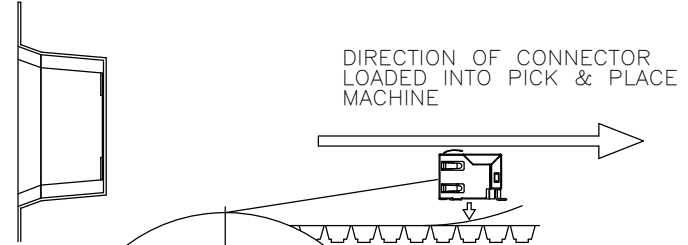
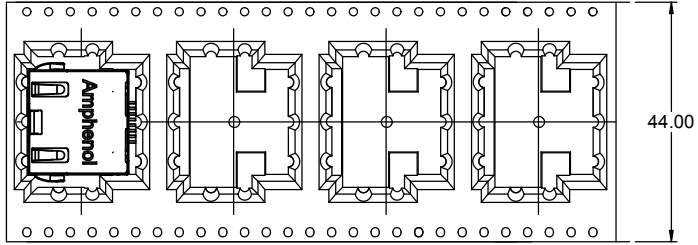

AMPHENOL P/N: RJE3A188XX01
 LOT# [Barcode] DATE CODE [Barcode] CTY OF ORIGIN: CN

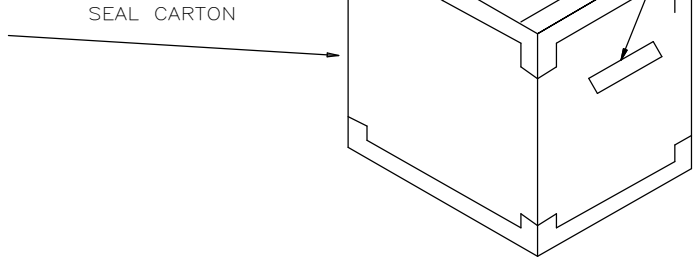
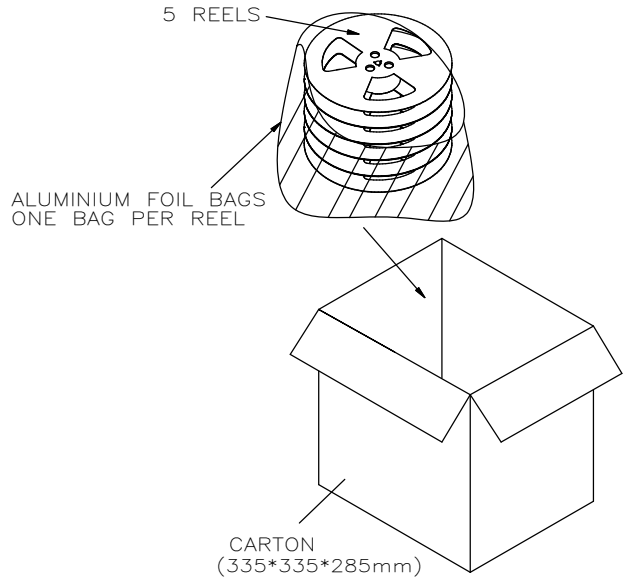

NOTES:

1. FINISHED CONNECTORS (AFTER FINAL INSPECTION) TO BE PACKED INTO CONDUCTIVE HIPS TAPE AND REEL. ONE REEL SHOULD HOLD 140 CONNECTORS.
2. 13 EMPTY POCKETS SEALED OF TAPE LEADER AND 7 EMPTY POCKETS SEALED OF TAPE TRAILER.
3. A FULLY LOADED CARTON SHOULD CONTAIN 5 REELS (700 PCS) OF CONNECTOR.

UNLESS SPECIFIED OTHERWISE	DRAWN	JAMISON.C	AUG16/19
PRIMARY UNITS MILLIMETERS	CHECKED	L.CHAN	AUG16/19
SECONDARY INCHES	M.E.	APP'D	
REFERENCE IN PARENTHESES	Q.A.	APP'D	
GENERAL TOLERANCES	DWG APPR.	A.GREEN	AUG16/19
1 DECIMAL PLACE ±0.38	ENG. REL. NO.		
2 DECIMAL PLACES ±0.25	REF.		
3 DECIMAL PLACES ±0.13	THIRD ANGLE PROJECTION		
ANGULAR DEGREES ±1°	DO NOT SCALE DRAWING		

Amphenol Canada Corp.
 Commercial Products

MODULAR JACK, SINGLE PORT, 8P8C, SHIELDED, TAB UP, WITHOUT LED, CAT 5e---RoHS COMPLIANT

DWG. NO. **P-RJE3A-188-1X01** REV **F**

CODE ID NO. 03554 DWG SIZE: N/A SCALE: FIT SHEET 2 OF 2