

Quickly upgraded to limit switches with lamps by mounting an LED lamp socket.



Rubber cover type (roller lever)

FEATURES

1. Subminiature limit switch

Managed to miniaturize the comparative bulk with high density mountings in the equipment's detector to approximately 1/3 of our own ML limit switches, or approximately 1/1.6 of the Z model microswitch.

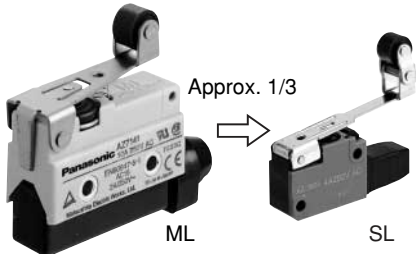

ML

SL

2. A lamp can be easily added for operations checks

An exposed terminal type model combined with a socket with cord for the built-in LED lamp (sold separately) easily become a limit switch with lamp. Convenient for maintenance checks such as operations checks.

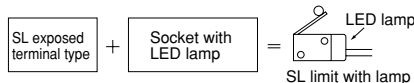

3. Operates with a light force

Comes in two types: O.F. is a maximum of 1.18N {120gf} (light force model) and light force commensurate to the microswitch.

4. Terminal uses both solder and tab (#110)

5. Achieves stroke tolerance (O.T./T.T.) of 0.67

Plenty of scope for position fixing with long life.

Because of the optimum design of the built-in limit switch and the original L-model spring for use in O.T. absorption, the total travel range has been enlarged, and both position fixing and the unit's lifespan have been improved a level.

Stroke range: 3 times more than the ML limit

6. Long life

By combining the excellent reliability and solvent proofing of the FS-T microswitch with the L shape spring, we have achieved a unit with both long life and high reliability (electrical life: 10⁵ mechanical life: 10⁷)

7. Built-in safety features and excellent environment proofing

The case uses 66 nylon glass fiber the doubly protect the switch. Also, the body and cap have been ultrasonically welded, creating a flush construction except for the terminals. Moreover, by adding a dedicated socket, the construction is drip-proof, dust-proof, and dirt-proof, creating a flush construction for the unit as a whole including the terminals.

Rubber cover type: Equivalent to IP60
Socket with cord type: Equivalent to IP64

TYPICAL APPLICATIONS

Dust proofing and oil resistance requirement.

PRODUCT TYPE

1. Switch body

Actuator	Operating Force (O.F.)	Exposed terminal type	Rubber cover type	Socket with cord type*
Hinge lever	1.18N {120gf}	AZ3012	AZ3512	AZ3712
	1.96N {200gf}	AZ3022	AZ3522	AZ3722
Roller lever	1.18N {120gf}	AZ3013	AZ3513	AZ3713
	1.96N {200gf}	AZ3023	AZ3523	AZ3723
One-way roller lever	1.96N {200gf}	AZ3024	AZ3524	AZ3724
Hinge short lever	2.94N {300gf}	AZ3025	AZ3525	AZ3725
Short roller lever	2.94N {300gf}	AZ3026	AZ3526	AZ3726
One-way short roller lever	2.94N {300gf}	AZ3027	AZ3527	AZ3727

Notes) 1. Socket with cord type is combination of; Exposed terminal type + Socket with cord (cord length: 1m 3.281ft.)

2. UL recognized, CSA certified type available. (See page 14.)

2. Socket

Applicable limit switches	Specifications	Part No.
Exposed terminal types	L socket	AZ3806
	Socket with cord (1 m 3.281ft.)	AZ3807
	Socket with cord (2 m 6.562ft.)	AZ3827
	Socket with cord (3 m 9.843ft.)	AZ3837
	Socket with cord (5 m 16.404ft.)	AZ3857

SL (AZ3)

3. Socket with LED (cord length: 1m 3.281ft.)

Applicable limit switches	Lamp Connection	Lamp rating	Part No.
Exposed terminal types	Normally open (N.O.) connection	6V DC	AZ3807162
		12V DC	AZ3807161
		24 to 48V DC	AZ380716
	Normally closed (N.C.) connection	6V DC	AZ3807362
		12V DC	AZ3807361
		24 to 48V DC	AZ380736

- Notes) 1. Types with 24 to 48V DC lamp rating are recommended for PC input use.
2. The following cord lengths are also available and lot-produced upon request.

Cord length	Part No.
2m	AZ38 [2]7*6*
3m	AZ38 [3]7*6*
5m	AZ38 [5]7*6*

The 5th digit (boxed) of part number denotes the length of cord.
Numerals come in the asterisked (*) digits, which show the lamp specifications.
The 7th digit: 1: N.O. connection, 3: N.C. connection
The 9th: None: 24 to 48V DC, 1: 12V DC, 2: 6V DC

FOREIGN STANDARDS

Standards	Applicable product	Part No.
UL recognized product	File No.: E122222 Ratings: 10 ⁵ rating 4A, 250V AC Product type: All products	Add "9" to the end of the part No.
CSA certified product	File No.: LR55880 Ratings: 10 ⁵ rating 4A, 250V AC Product type: All products excluding types with socket and cord.	

SPECIFICATIONS

1. Rating

Rated control voltage	125V AC	250V AC	30V DC	125V DC
Resistive load (cos $\phi \approx 1$)	4A	4A	4A	0.1A
Inductive load (cos $\phi \approx 0.4$)	2.5A	2.5A	2.5A	0.1A

2. Characteristics

Contact arrangement	1 From C	
Initial contact resistance, max.	60 m Ω (By voltage drop 5 to 6V DC 1A)	
Contact material	AgNi contact	
Initial insulation resistance (At 500V DC)	Min. 100M Ω	
Initial breakdown voltage	Between non-consecutive terminals	1000 Vrms for 1 min
	Between dead metal parts and each terminal	1500 Vrms for 1 min
	Between ground and each terminal	1500 Vrms for 1 min
Expected life (min. operations)	Mechanical	10 ⁷ (at 60 cpm)
	Electrical	10 ⁵ (at 20 cpm, 4A 250V AC resistive)
Ambient temperature	-20 to +60°C -4 to +140°F	
Ambient humidity	Max. 95% R.H.	
Max. operating speed	120 cpm	

3. Mechanical characteristics

Actuator	Hinge lever		Roller lever		One-way roller lever	Hinge short lever	Short roller lever	One-way short roller lever	
Operating Force (O.F.)	1.18N {120gf}	1.96N {200gf}	1.18N {120gf}	1.96N {200gf}	1.96N {200gf}	2.94N {300gf}	2.94N {300gf}	2.94N {300gf}	
Shock resistance, min.	In the free position	98m/s ² {10G}	294m/s ² {30G}	98m/s ² {10G}	196m/s ² {20G}	147m/s ² {15G}	294m/s ² {30G}	196m/s ² {20G}	147m/s ² {15G}
	In the full operating position	294m/s ² {30G}	294m/s ² {30G}	294m/s ² {30G}	294m/s ² {30G}	294m/s ² {30G}	294m/s ² {30G}	294m/s ² {30G}	294m/s ² {30G}
Vibration resistance	Vibration rate	10 to 55Hz	10 to 45Hz	10 to 55Hz	10 to 45Hz	10 to 55Hz	10 to 55Hz	10 to 55Hz	
	Double amplitude	1.5mm .059inch	1.0mm .039inch	1.5mm .059inch	1.0mm .039inch	1.5mm .059inch	1.5mm .059inch	1.5mm .059inch	

4. Operating characteristics

Actuator	Characteristics	O.F. (N(gf)) max.		R.F. (N(gf)) min.		Pretravel (P.T.), max. mm inch	Movement Differential (M.D.), max. mm inch	Overtravel (O.T.), min. mm inch	Operating Position (O.P.) mm inch
		Hinge lever	1.18 {120}	1.96 {200}	0.24 {25}	0.49 {50}	3.0 .118	1.5 .059	6.0 .236
Roller lever		1.18 {120}	1.96 {200}	0.24 {25}	0.49 {50}	3.0 .118	1.5 .059	6.0 .236	30.7±1.5 1.209±.059
One-way roller lever		1.96 {200}		0.49 {50}		3.0 .118	1.5 .059	6.0 .236	40.5±1.5 1.594±.059
Hinge short lever		2.94 {300}		0.59 {60}		2.0 .079	1.0 .039	3.5 .138	13.7±1.5 .539±.059
Short roller lever		2.94 {300}		0.59 {60}		2.0 .079	1.0 .039	3.5 .138	27.7±1.5 1.091±.059
One-way short roller lever		2.94 {300}		0.59 {60}		2.0 .079	1.0 .039	3.5 .138	36.7±1.5 1.445±.059

Note) For the operating characteristics, refer to the TECHNICAL INFORMATION.

5. Protective characteristics

Protective construction	Rubber cover type	Types with socket and cord
IEC		
IP60	○	○
IP62	—	○
IP63	—	○
IP64	—	○

6. LED rating

Rated operating voltage	Operating voltage range	Internal resistance
6V DC	5 to 15V DC	2.4K Ω
12V DC	9 to 28V DC	4.7K Ω
24 to 48V DC	20 to 55V DC	15K Ω

DATA

1. Life curve

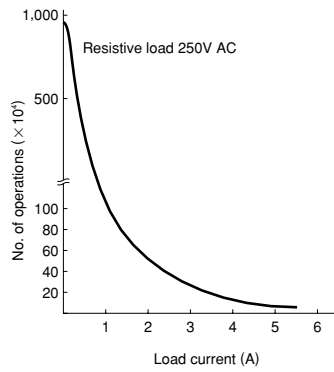

2. Actual load life curve

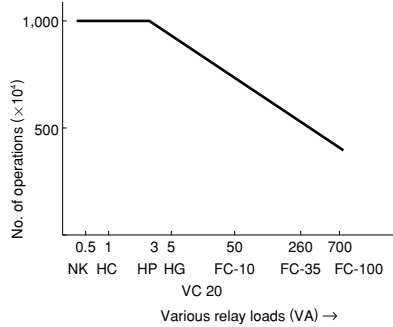

Note: The FC magnetic contactor series is 200V AC.
The NK is 2 Form C 24V DC type.

WIRING DIAGRAMS

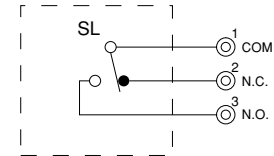

DIMENSIONS

1. Rubber cover Hinge lever

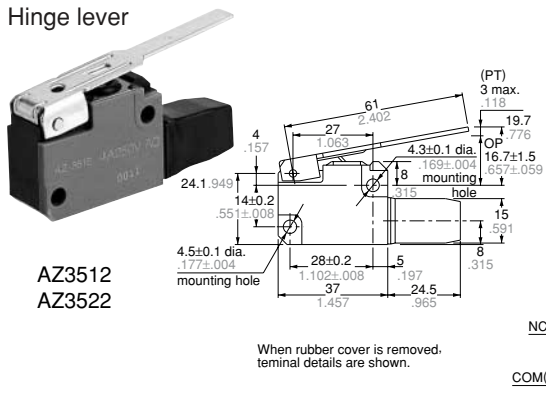

Roller lever

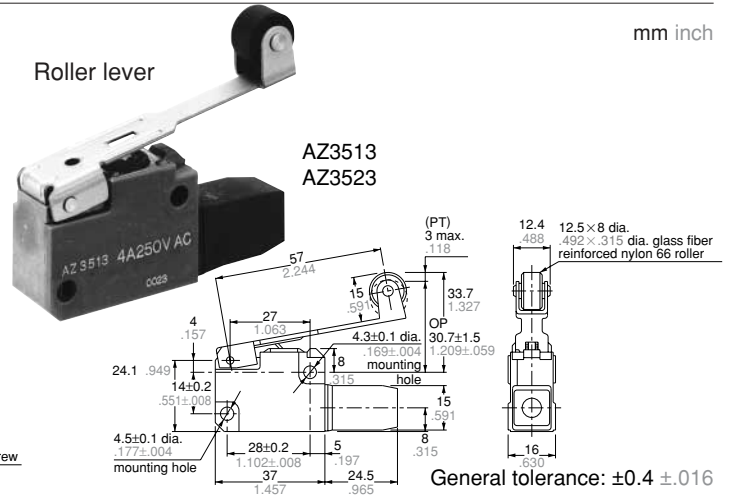

One-way roller lever

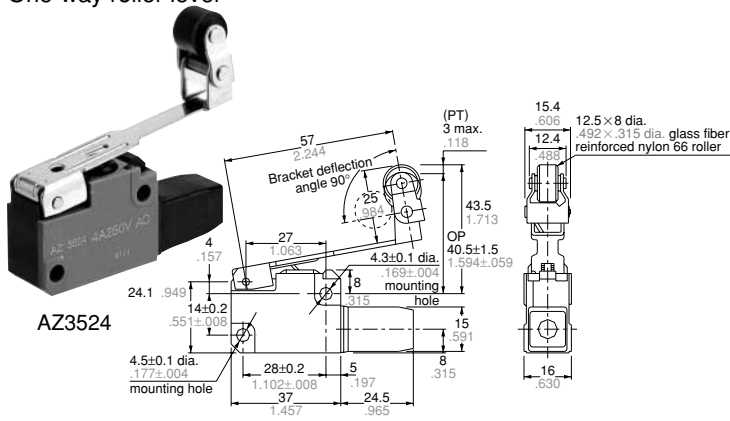

Hinge short lever

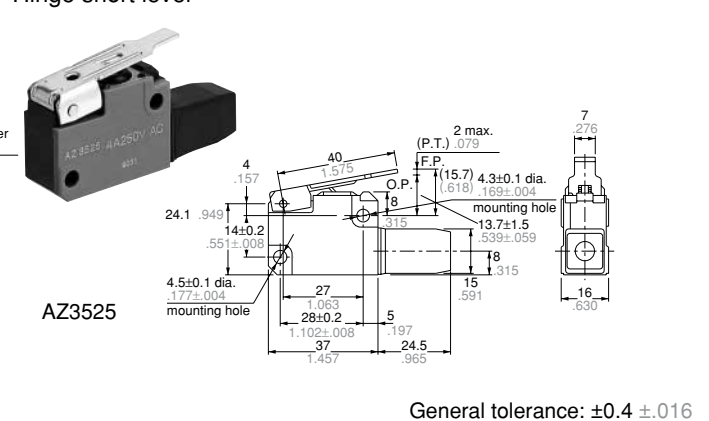

Short roller lever

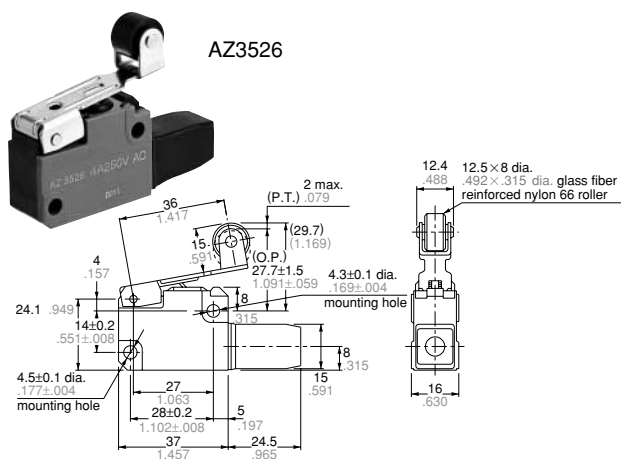

One-way short roller lever

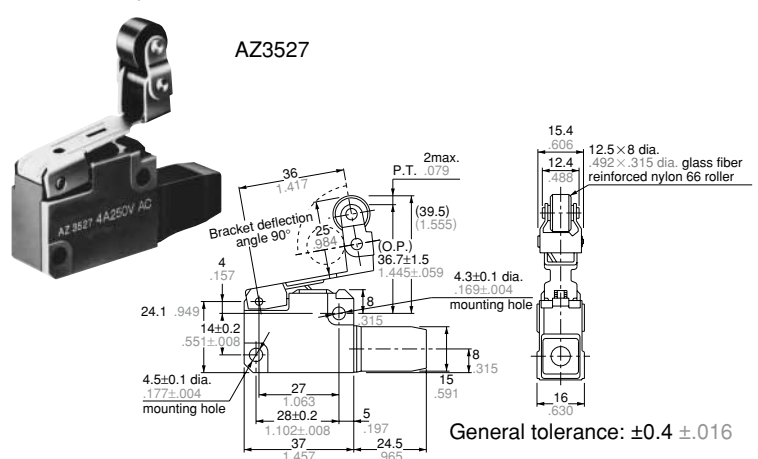

SL (AZ3)

2. Exposed terminal type
Hinge lever

3. Socket with cord type
One-way roller lever

mm inch

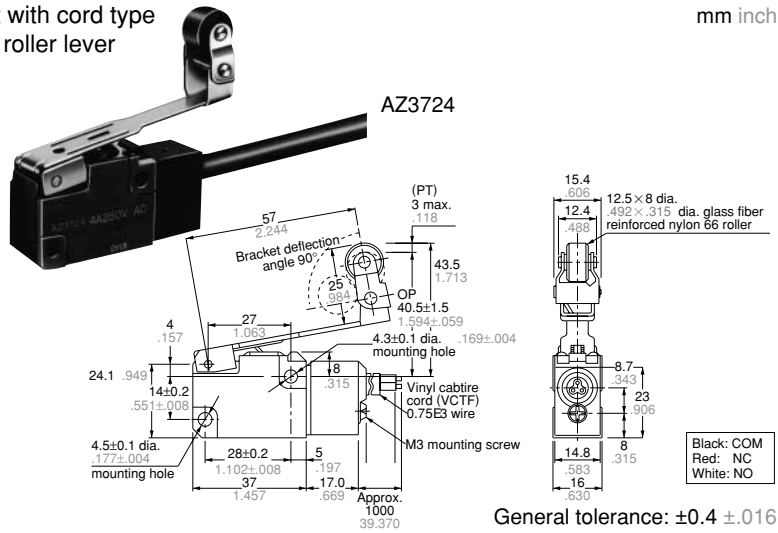
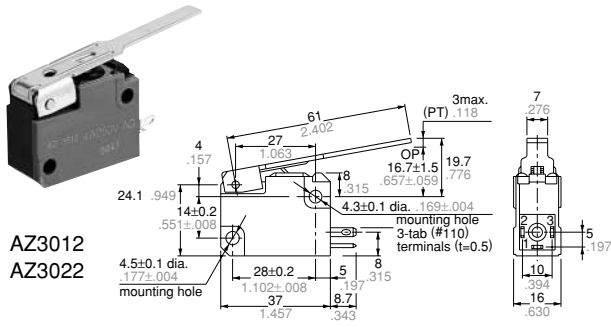

Note) The following types are also available.
Roller lever: AZ3013, AZ3023
One-way roller lever: AZ3024
Hinge short lever: AZ3025
Short roller lever: AZ3026
One-way short roller lever: AZ3027

(Combination of the AZ3024 exposed terminal type and the AZ3807 socket with cord type)
Note) The following types are also available.
Hinge lever: AZ3712, AZ3722
Roller lever: AZ3713, AZ3723
Hinge short lever: AZ3725
Short roller lever: AZ3726
One-way short roller lever: AZ3727

CONNECTION METHOD FOR RUBBER COVER

1) Remove the rubber cover from the limit switch.

3) Connect lead wire to the receptacle terminals (#110) with insulating sleeve provided and insert it into the terminal of limit switch. (The lead wire can directly be soldered to the terminals without using receptacle terminals)

4) Push the rubber cover securely over the terminals.



2) After stripping the sheath from the appropriate cord (refer to table on the right) and removing the covering of the lead wires, insert the cord into the rubber cover.

Wire name	Applicable wire		
	Conductor	Wire strand	Finished outside diameter
Vinyl cabtire cord (VCTF)	0.75mm ²	2-wire	6.6mm .260inch dia.
	0.75mm ²	3-wire	7.0mm .276inch dia.

CAUTIONS

1. Ambient conditions

- 1) The use of these switches under the following conditions should be avoided. If the following conditions should become necessary, we recommend consulting us first.
 - Use where there will be direct contact with organic solvents, strong acids or alkalis, or direct exposure to their vapors.
 - Use where inflammable or corrosive gases exist.
 - Because these switches are not of water resistant or immersion-proof construction, their use in water or oil should be avoided. Also, locations where water or oil can normally impinge upon the switch or where there is an excessive accumulation of dust should be avoided.
- 2) To improve reliability during actual use, it is recommended that the operation be checked under installation conditions.
- 3) If OT is too big, the life of limit switch will be shortened switching friction. Use it with enough margin of OT. 70% of OT standard value will be good for use.
- 4) Do not use the switch in a silicon atmosphere. Care should be taken where organic silicon rubber, adhesive, sealing material, oil, grease or lead wire generates silicon.
- 5) Avoid use in excessively dusty environments where actuator operation would be hindered.
- 6) When used outdoors (in places where there is exposure to direct sunlight or rain such as in multistory car parks) or in environments where ozone is generated, the influence of these environments may cause deterioration of the rubber material. Please consult us if you intend to use a switch in environments such as these.

2. Mounting and wiring

- 1) Although SL limit switches have large over-travel (O.T.), excessive O.T. will occur wear and change in its characteristics. Specifically, where there is a need for long life, it is recommended that the proper O.T. as given below should be used. Specifically, where there is a need for long life, it is recommended that the proper O.T. as given below should be used.
 - Within 1 to 3mm .039 to .118inch
- 2) When the operating object is in the free condition, force should not be applied directly to the actuator.
- 3) Use their own accessories when mounting and wiring SL limit switches so as to maintain their own characteristics. When the SL rubber cover type is used, there should absolutely be no tension applied to the cord. If there is the fear that tension may be applied, the L socket or socket with cord attached should be used. The maximum permissible tension with the above socket use is 98N{10kgF}.
- 4) The tightening torque when installing this limit switch should be 1.18 to 1.47 N·m (12 to 15 kg·cm).