

1. 製品名称 : 2.0mm PITCH W/B CONN. WAFER ASS'Yエンボステープ梱包
Product Name: 2.0mm PITCH W/B CONN. WAFER ASS'Y EMBOSSED TAPE PACKAGE

製品番号 (エンボス梱包品) : 502352-**00, 502352-**10, 502352-**01, 502352-**11, 502352-**02,
502352-**03 (**は極数を示す)

Part Number (Embossed Tape Package): 502352-**00, 502352-**10, 502352-**01, 502352-**11,
502352-**02, 502352-**03 (** is circuits size)

製品番号 (コネクタ単体) : 502352-**08, 502352-**18, 502352-**28, 502352-**38, 502352-**48,
502352-**68 (**は極数を示す)

Part Number (Connector): 502352-**08, 502352-**18, 502352-**28, 502352-**38, 502352-**48,
502352-**68 (** is circuits size)

2. 標準梱包数
STANDARD PACKAGING QUANTITY

2-1 成都生産品
Produced in Chengdu

| 極数 CKT | リール&エンボステープ REEL & EMBOSSED TAPE | | | トップテープ TOP TAPE | 外装カートン SHIPPING CARTON 47799-1038 | |
|-----------|-------------------------------------|----------------|-----------------|--------------------|---|------------------|
| | 型番 PROD. NO. | 幅 WIDTH(mm) | 製品数 QUANTITY | 型番 PROD. NO. | 梱包リール数 NUMBER OF REELS | 製品数 QUANTITY |
| 2 | 47799-5067 | 24 | 700 | 47799-5096 | 6 (3) | 4,200 (2,100) |
| 3 | 47799-5102 | | | | | |
| 4 | 47799-5074 | | | | | |
| 5 | 47799-5103 | | | | | |
| 6 | 47799-5068 | 32 | 700 | 47799-5097 | 4 (2) | 2,800 (1,400) |
| 7 | 47799-5104 | | | | | |
| 8 | 47799-5075 | | | | | |
| 9 | 47799-5230 | | | | | |
| 10 | 47799-5231 | 44 | 700 | 47799-5098 | 3 (1) | 2,100 (700) |
| 11 | 47799-5232 | | | | | |
| 12 | 47799-5145 | | | | | |
| 13 | 47799-5233 | | | | | |
| 14 | 47799-5234 | 56 | 700 | 47799-5099 | 3 (1) | 2,100 (700) |
| 15 | 47799-5235 | | | | | |

注 : () 内の数は、少量出荷用カートンを用いた場合の梱包数。
NOTE: "() Numbers are applicable for small lot shipment.

| | | | | | | | | | | | | | | | | | | | |
|--|---|-----|-----|--------|-----|---|-----------------------------|--------------------------------|-------------------------------|--|--|--------------------------------|--|--|--|-----------------|--|--|--|
| REV. | A | B | C | D | E | | | | | | | | | | | | | | |
| SHEET | 1-3 | 1-3 | 1-3 | 1-3 | 1-4 | | | | | | | | | | | | | | |
| REVISE ON PC ONLY | | | | | | TITLE: | | | | | | | | | | | | | |
| E | REVISED JTR2016-0116 2016/06/02 K.NAGAI | | | | | 502352梱包仕様書 PACKAGING SPEC. FOR 502352 | | | | | | | | | | | | | |
| | THIS DOCUMENT CONTAINS INFORMATION THAT IS PROPRIETARY TO INC. AND SHOULD NOT BE USED WITHOUT WRITTEN PERMISSION | | | | | | | | | | | | | | | | | | |
| REV. | DESCRIPTION | | | | | | | | | | | | | | | | | | |
| DESIGN CONTROL JTR | | | | STATUS | | WRITTEN BY: K.NAGAI | CHECKED BY: H.KOMATSU | APPROVED BY: MA.YAMAMOTO | DATE: YR/MO/DAY 2012/09/11 | | | | | | | | | | |
| DOCUMENT NUMBER PK-502352-002-JP | | | | | | | | | | | | FILE NAME PK502352002JP.DOC | | | | SHEET 1 OF 4 | | | |
| EN-37(2012-03) | | | | | | | | | | | | | | | | | | | |

molex**PACKAGING SPECIFICATION**

LANGUAGE

JAPANESE
ENGLISH2-2 韓国生産品
Produced in Korea

| 極数 CKT | リール&エンボステープ REEL & EMBOSSED TAPE | | | | トップテープ TOP TAPE | 外装カートン SHIPPING CARTON 59411-0002 | |
|-----------|-------------------------------------|--|--------------------|-----------------|--------------------|---|-----------------|
| | リール型番 REEL PROD. NO. | エンボス テープ 型番 EMBOSS TAPE PROD. NO. | 幅 WIDTH (mm) | 製品数 QUANTITY | 型番 PROD. NO. | 梱包リール数 NUMBER OF REELS | 製品数 QUANTITY |
| 2 | 35908-1022 | 59407-0802 | 24 | 700 | 59406-5203 | 6 | 4,200 |
| 3 | | 59407-0803 | | | | | |
| 4 | | 59407-0804 | | | | | |
| 5 | | 59407-0805 | | | | | |
| 6 | 35908-1023 | 59407-0806 | 32 | 700 | 59406-5204 | 4 | 2,800 |
| 7 | | 59407-0807 | | | | | |
| 8 | | 59407-0808 | | | | | |
| 9 | 35908-1024 | 59407-0809 | 44 | 700 | 59406-5205 | 3 | 2,100 |
| 10 | | 59407-0810 | | | | | |
| 11 | | 59407-0811 | | | | | |
| 12 | | 59407-0812 | | | | | |
| 13 | 35908-1025 | 59407-0813 | 56 | 700 | 59406-5206 | 3 | 2,100 |
| 14 | | 59407-0814 | | | | | |
| 15 | | 59407-0815 | | | | | |

REVISE ON PC ONLY

E

SEE SHEET 1 OF 4

TITLE:

502352梱包仕様書
PACKAGING SPEC. FOR 502352THIS DOCUMENT CONTAINS INFORMATION THAT IS PROPRIETARY TO
INC. AND MUST NOT BE USED WITHOUT WRITTEN PERMISSION

REV.

DESCRIPTION

DOCUMENT NUMBER

PK-502352-002-JP

FILE NAME

PK502352002JP.DOC

SHEET

2 OF 4

EN-037(2012-03)

3. 梱包方法
PACKAGING PROCEDURE

- 1). 規定数量に基づき、製品をエンボス梱包する。
- 2). リールにラベルを貼り付ける。ラベルには数量、型番、ロットを明記する。
- 3). カートンへリールを規定数量入れる。
- 4). カートンを閉じてテープでとめる。
- 5). 外側にラベルを貼り付ける。ラベルには数量、型番、ロットを明記する。

- 1). Package the appropriate number of parts in the embossed tape.
- 2). Place the label on the outside of the reel. On the label, quantity, part number, lot number needs to be specified.
- 3). Put the appropriate number of reel into the carton crucially.
- 4). Close the box, and tape the box.
- 5). Place the label on the outside of the box. On the label, quantity, part number, lot number needs to be specified.

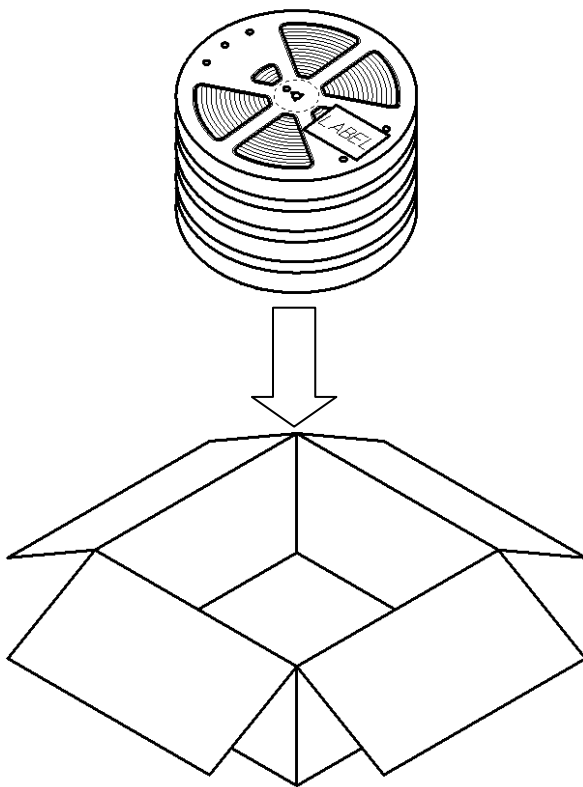

| | | | |
|--|------------------|---|-----------------|
| REVISE ON PC ONLY | | TITLE: | |
| E | SEE SHEET 1 OF 4 | 502352梱包仕様書 PACKAGING SPEC. FOR 502352 | |
| REV. | DESCRIPTION | THIS DOCUMENT CONTAINS INFORMATION THAT IS PROPRIETARY TO INC. AND MUST NOT BE USED WITHOUT WRITTEN PERMISSION | |
| DOCUMENT NUMBER PK-502352-002-JP | | FILE NAME PK502352002JP.DOC | SHEET 3 OF 4 |
| EN-037(2012-03) | | | |

4. ラベル位置
LABEL POSITION

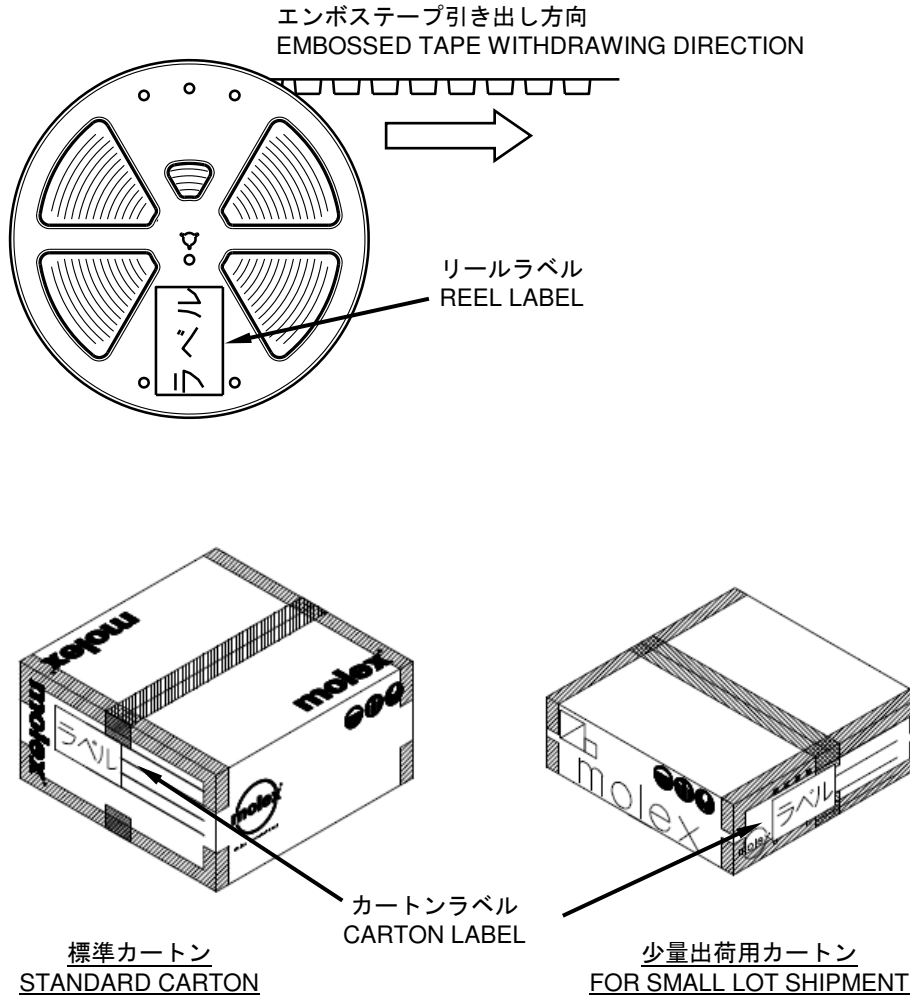

| | | |
|-------------------------------------|-------------------|--|
| E | REVISE ON PC ONLY | TITLE: 502352梱包仕様書 PACKAGING SPEC. FOR 502352 |
| | SEE SHEET 1 OF 4 | |
| REV. | DESCRIPTION | THIS DOCUMENT CONTAINS INFORMATION THAT IS PROPRIETARY TO INC. AND MUST NOT BE USED WITHOUT WRITTEN PERMISSION |
| DOCUMENT NUMBER PK-502352-002-JP | | FILE NAME PK502352002JP.DOC |
| | | SHEET 4 OF 4 |
| EN-037(2012-03) | | |