

used for: D-SUB HD FILTER

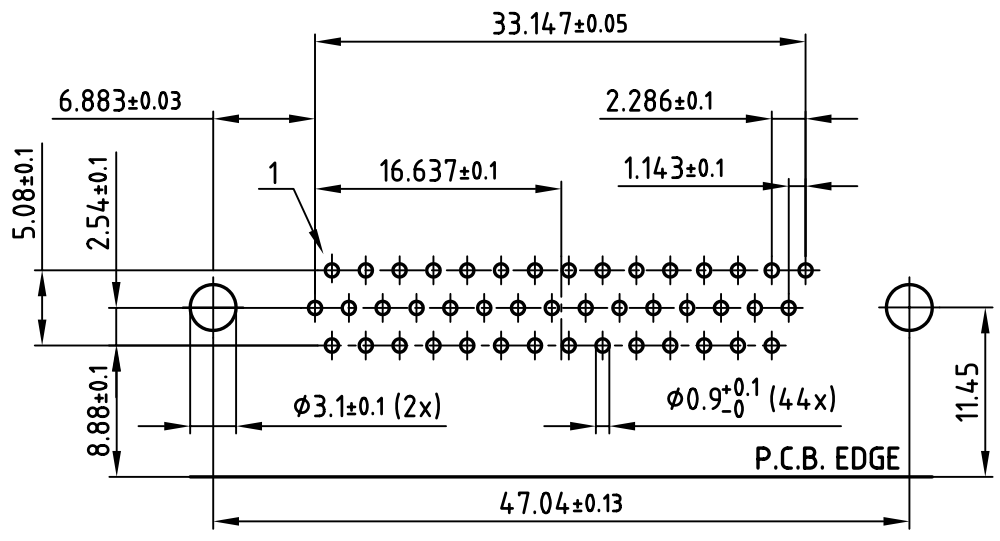

P.C.B. HOLE DRILLINGS

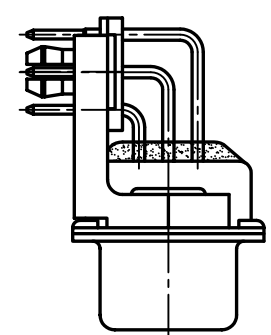
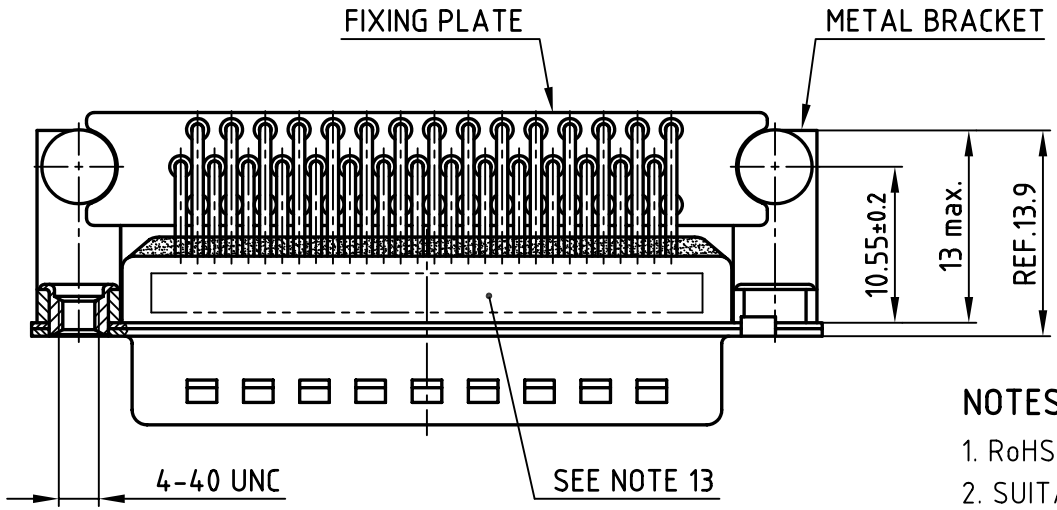
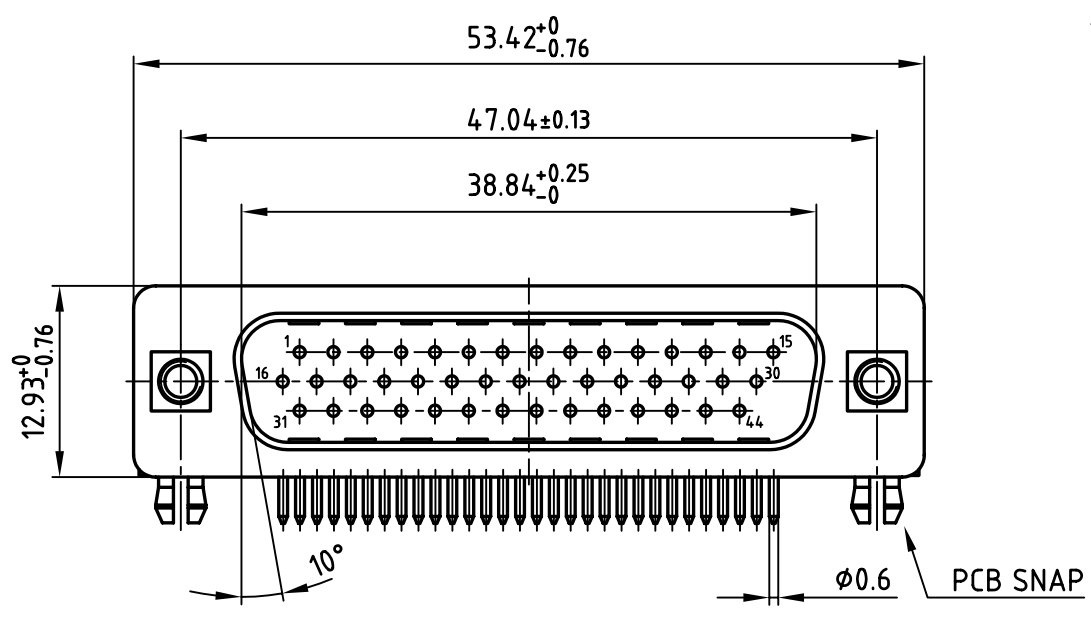
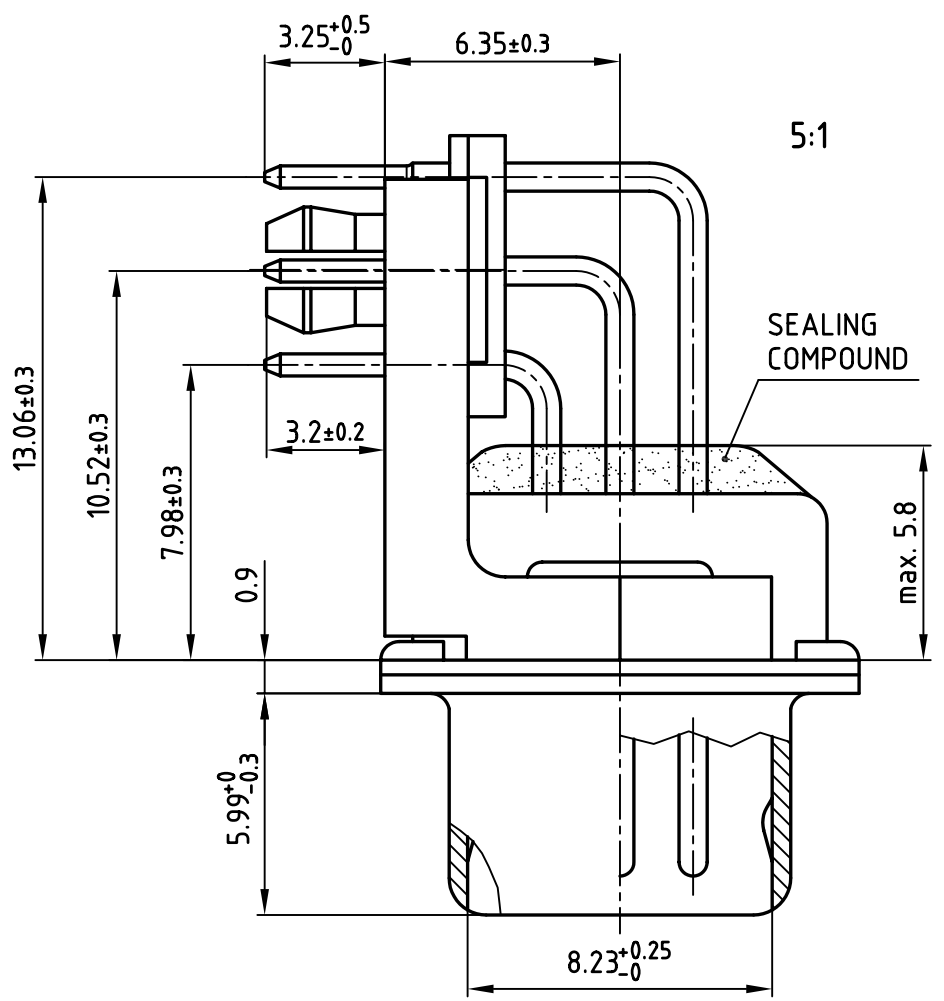

NOTES:

1. RoHS COMPLIANT
2. SUITABLE FOR WAVE SOLDERING
3. METALSHELLS: STEEL; min. 315µin TIN over 40-80µin NICKEL
4. INSULATORS: HIGH TEMPERATURE PLASTIC UL 94 V-0; BLACK
5. CONTACTS: COPPER ALLOY
PLATING: 8µin HARD GOLD OVER min. 50µin NICKEL
CONTACT TAILS PRETINNED
6. METAL BRACKET: ZINC DIE CAST; 300µin COPPER
40-120µin NICKEL/120-200µin TIN
7. THREADED INSERT: COPPER ALLOY; min. 200µin TIN over 80µin NICKEL
8. PCB-SNAP: COPPER ALLOY; min. 200µin TIN over 80µin NICKEL
PCB-HOLE: 3.1±0.1; PCB THICKNESS 1.6mm
9. FIXING-PLATE: PBT GF UL 94 V-0, BLACK
10. CAPACITANCE: 830pF ±20%
11. DIELECTRIC WITHSTANDING VOLTAGE: 300 VDC
12. MAXIMUM TORQUE VALUE FOR THREAD: 6 in.LB
13. CONNECTOR IS PART MARKED: 241A17960X CONEC ABC

Directive 2002/95/EC
„RoHS“
Compliant

APPROVAL # FREIGABE # DEBLOCAGE # AUTORIZACION # APPROVAL

CUSTOMER APPROVAL DATE:

NAME: TITLE:

COMPANY NAME:

APPROVAL # FREIGABE # DEBLOCAGE # AUTORIZACION # APPROVAL

THIS DRAWING MAY NOT BE COPIED OR REPRODUCED IN ANY WAY, AND MAY NOT BE PASSED ON TO A THIRD PARTY WITHOUT WRITTEN PERMISSION.

OWNERSHIP AND COPYRIGHT OF CONEC GmbH

DO NOT ALTER CAD DRAWING BY HAND

tolerance		dim. in mm	scale: 2:1 (5:1)	
			material: SEE NOTES	
2008	date	title:		
drawn	05.09.	D-SUB HD FILTER MALE 90°		
appd.	05.09.	44pos. 0.350inch		
norm		with threaded insert, metal bracket and snap		
DIN 41652		dwg no: AutoCAD 2006		
d-old		DIN-A		
a	Origin	24K1A1109		
rev.	description	part no: 241A17960X		
date	name	sh: 1/1		

