

THIS DRAWING IS UNPUBLISHED. RELEASED FOR PUBLICATION 20  
 © COPYRIGHT 20 BY - ALL RIGHTS RESERVED.

REVISIONS					
P	LTR	DESCRIPTION	DATE	DWN	APVD
A		INITIAL RELEASE	18JUL2019	A.Z	C.W
A1		CORRECT DRAFT ERROR	16OCT2019	A.Z	C.W
A2		CLARIFY TYPICAL PNS	22JUN2020	A.Z	C.W
A3		CLARIFY WIRE MAP	25AUG2020	A.Z	C.W

ITEM	DESCRIPTION	MATERIAL	OTHERS
1	MALE CONTACT	COPPER ALLOY	GOLD PLATED
2	HOUSING	NYLON	BLACK
3	COUPLING NUT	COPPER ALLOY	NICKEL PLATED
4	OVER-MOLDING	TPU/PVC	BLACK
5	SHIELDED SHELL	COPPER ALLOY	NICKEL PLATED
6	CABLE	-	-
7	LABEL	-	-

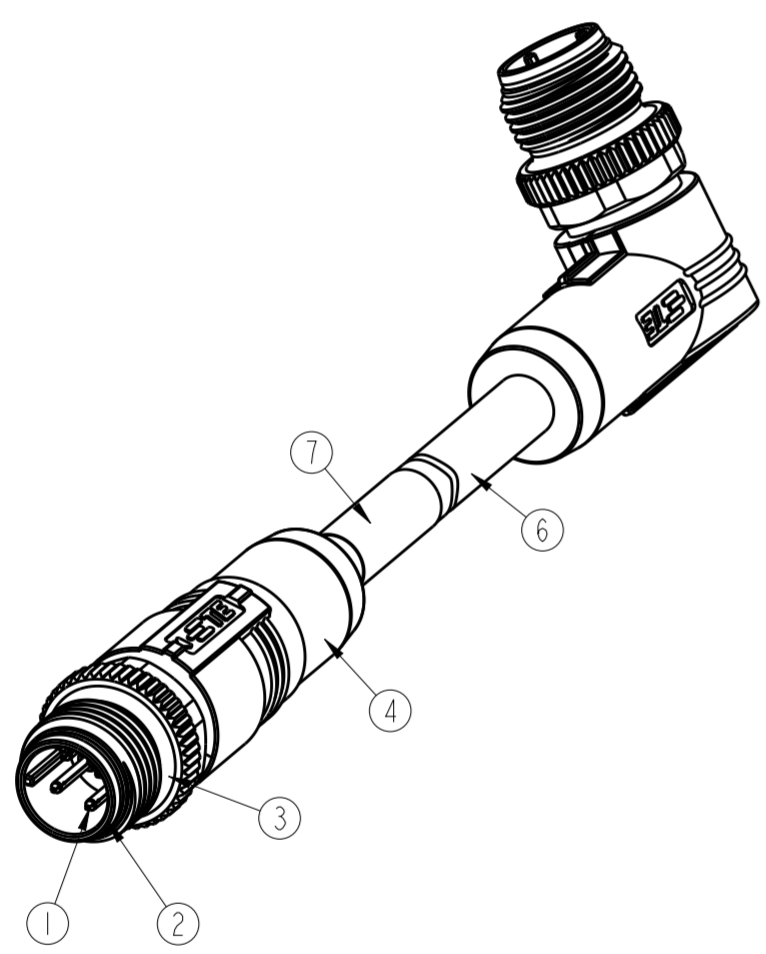
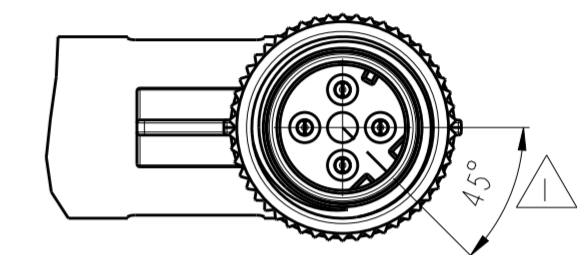
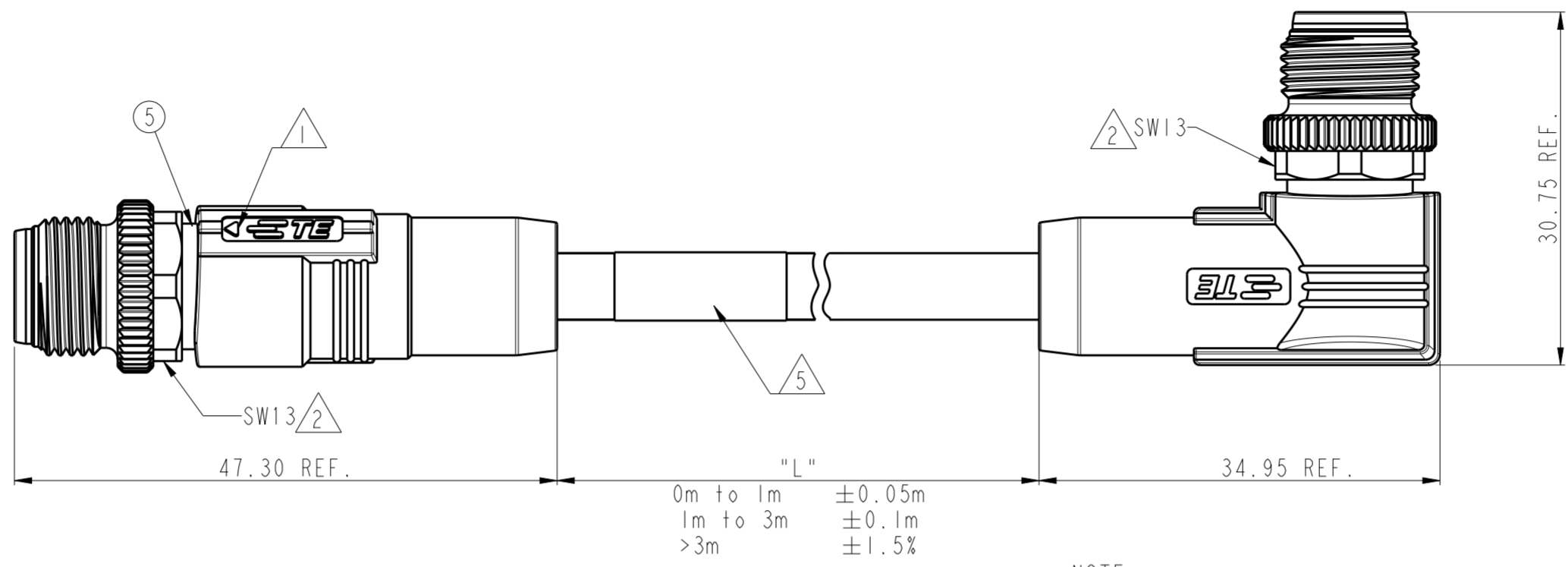

NOTE:

- ①. CODE POSITION INDICATOR
- ②. RECOMMENDED TORQUE 0.6 Nm
- ③. -\*\* : CABLE LENGTH, FOR EXAMPLE: -0.5M
- ④. CABLE ASSEMBLY TO BE PACKAGED IN POLYBAGS
- ⑤. LABEL CONTAINS: PN, DATE CODE...
- ⑥. -XXX: FOR CABLE LENGTH, SEE TABLE 2 AND REFER TO LENGTH "L"

注释:

- ①. CODE位置指示
- ②. 推荐扭矩0.6 Nm
- ③. -\*\* : 线缆长度, 例如: -0.5M
- ④. 线缆组件塑料袋包装
- ⑤. 标签包含: 产品编号, 日期代码...
- ⑥. -XXX: 线缆长度, 参考表2, 参照长度"L"

WIRES	WIRE COLOR	OD	TEMPERATURE RATING	OPERATING TEMP RATING	JACKET COLOR	JACKET MATERIAL	TYPE	POS.	TABLE 2 TE PN
WIRES: 1X4X22AWG WIRE COLOR: WHITE/YELLOW/BLUE/ORANGE OD: APPROX. 6.5MM TEMPERATURE RATING: 80°C UL OPERATING TEMP RATING: -40°C To +80°C	RED	PVC	M12D4-MS-MR-PVC TYPE B RED-**③	4	TAD14841311-XXX⑥				
WIRES: 1X4X22AWG WIRE COLOR: WHITE/YELLOW/BLUE/ORANGE OD: APPROX. 6.65MM TEMPERATURE RATING: 80°C UL OPERATING TEMP RATING: -30°C To +70°C DRAG CHAIN TEST: MIN. 1 MILLION CYCLES, DIAMETER 75MM, SPEED 2m/s, ACCELERATION 2m/s <sup>2</sup>	GREEN	PUR	M12D4-MS-MR-PUR TYPE C GREEN-**③	4	TAD14845101-XXX⑥				
WIRES: 1X4X22AWG WIRE COLOR: WHITE/YELLOW/BLUE/ORANGE OD: APPROX. 6.5MM TEMPERATURE RATING: 80°C UL OPERATING TEMP RATING: -25°C To +80°C	GREEN	FRNC	M12D4-MS-MR-FRNC TYPE B GREEN-**③	4	TAD14847101-XXX⑥				
WIRES: 1X4X22AWG WIRE COLOR: WHITE/YELLOW/BLUE/ORANGE OD: APPROX. 6.5MM TEMPERATURE RATING: 80°C UL OPERATING TEMP RATING: -40°C To +80°C	GREEN	PVC	M12D4-MS-MR-PVC TYPE B GREEN-**③	4	TAD14841111-XXX⑥				
CABLE CHARACTERISTIC	LENGTH "L"	JACKET COLOR	JACKET MATERIAL	TYPE	POS.	TABLE 2 TE PN			

PIN ARRANGEMENT D-CODE

PIN 1	TD+	YELLOW / 黄
PIN 3	TD-	ORANGE / 橙
PIN 2	RD+	WHITE / 白
PIN 4	RD-	BLUE / 蓝

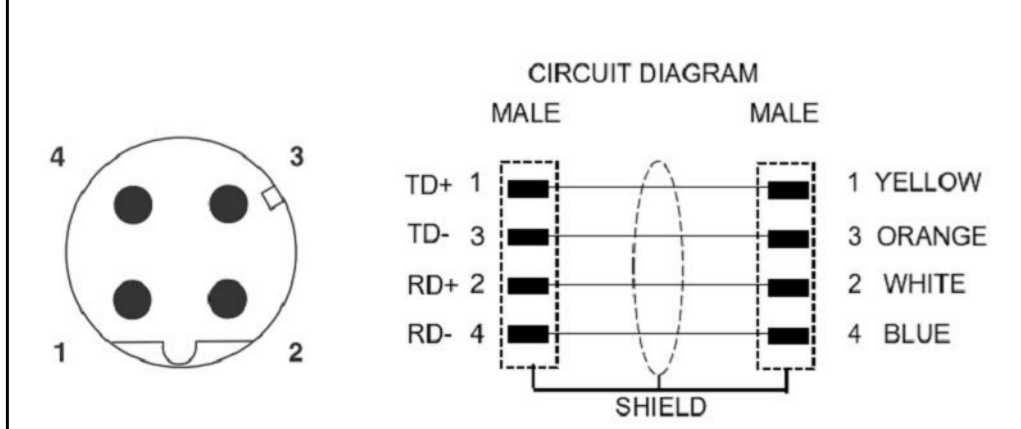

③

THIS DRAWING IS A CONTROLLED DOCUMENT.

DIMENSIONS:	TOLERANCES UNLESS OTHERWISE SPECIFIED:
mm	0 PLC ±
	1 PLC ±
	2 PLC ±
	3 PLC ±
	4 PLC ±
	ANGLES ±
MATERIAL	FINISH

DWN: ALEX ZHANG	CHK: HART HE	APVD: CHRIS WANG	DATE: 11 APR 2019
NAME: M12 D CODE CABLE ASSY, SHIELDED 4P, MS TO MR		PRODUCT SPEC: 108-106140	
APPLICATION SPEC: 114-137144		SIZE: A2	SCALE: 2:1
WEIGHT: -		CAGE CODE: -	SHEET: 1 OF 2
CUSTOMER DRAWING		REV: A3	

THIS DRAWING IS UNPUBLISHED. RELEASED FOR PUBLICATION 20  
 © COPYRIGHT 20 BY - ALL RIGHTS RESERVED.

REVISIONS				
P	LTR	DESCRIPTION	DATE	APVD
-		SEE SHEET 1	-	-

TECHNICAL DATA	
RATED VOLTAGE	250V 30V(UL)
RATED CURRENT	4A 1.5A(UL)
POLLUTION DEGREE	3
OVERVOLTAGE CATEGORY	II
MATERIAL GROUP	II
DEGREE OF PROTECTION	IP67

**TE PN CODING:**

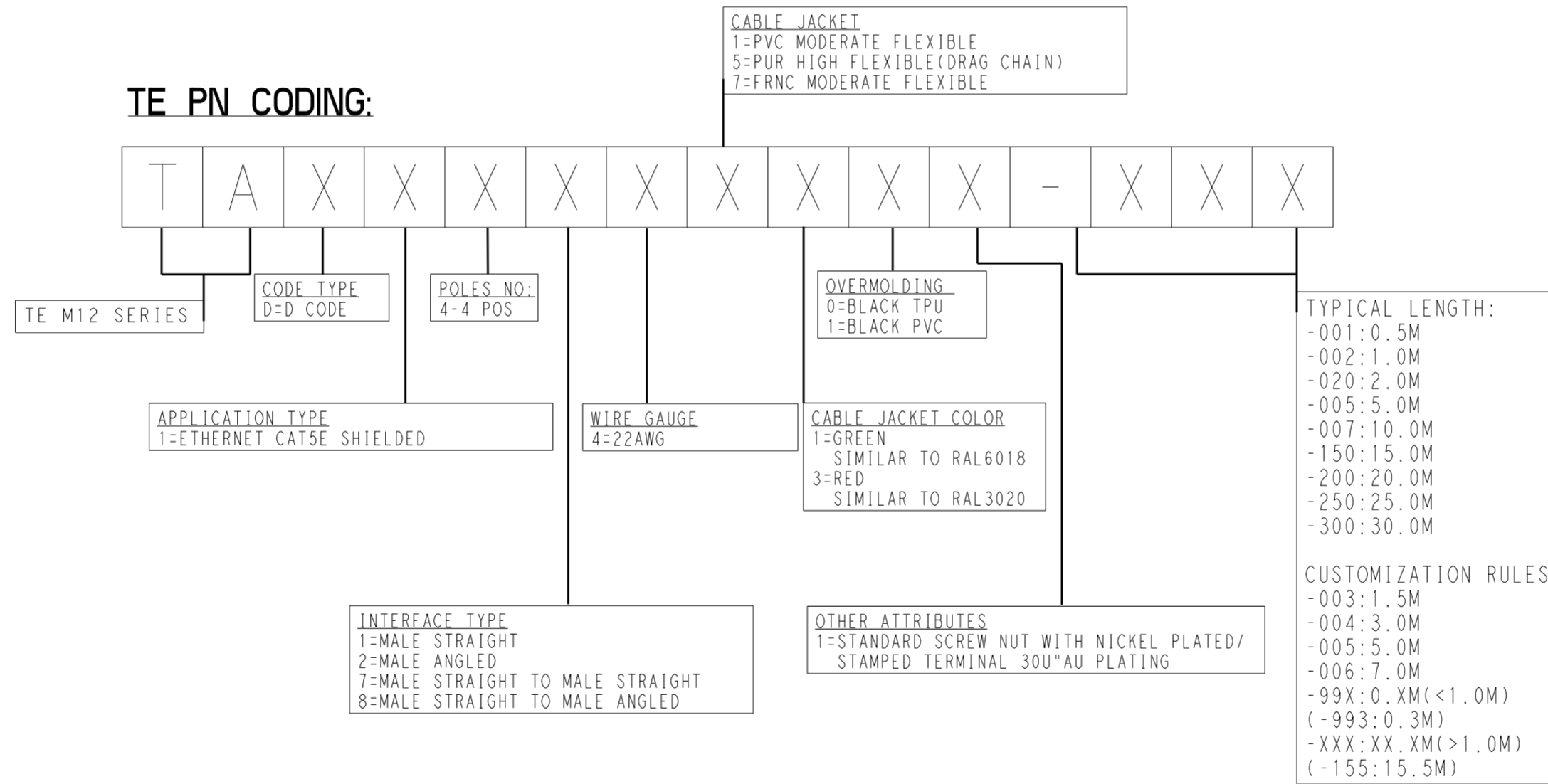

THIS DRAWING IS A CONTROLLED DOCUMENT.		DWN ALEX ZHANG CHK HART HE APVD CHRIS WANG	11 APR 2019 HART HE HART HE	TE Connectivity			
DIMENSIONS: mm 		PRODUCT SPEC 108-106140 APPLICATION SPEC 114-137144				NAME M12 D CODE CABLE ASSY, SHIELDED 4P, MS TO MR	
TOLERANCES UNLESS OTHERWISE SPECIFIED: 0 PLC ± 1 PLC ± 2 PLC ± 3 PLC ± 4 PLC ± ANGLES ± FINISH -		WEIGHT - CUSTOMER DRAWING		SIZE A2	CAGE CODE -	DRAWING NO G-TAD1484XXXXXX	RESTRICTED TO
				SCALE 2:1	SHEET 2 OF 2	REV A3	