

User Guide
MP-HW80EVAL-01
Analog DC-DC
Evaluation Board

Table of Contents

1. Introduction	3
2. Setup	4
2.1 Connections	4
2.2 On Board Component Values	5
2.2.3 OCP Resistor Value	5
2.2.4 Under Voltage Lockout (UVLO)	5
2.2.5 Output Voltage Trim Resistors	5
2.2.6 Sense Connections	6
2.2.7 Hold Up Circuit	6
2.2.8 External Fusing	6
2.2.9 Pulse Out	7
2.2.10 On/Off Control	7
3. EMI Circuit	8
4. Circuit Schematic	10
5. Mechanical Drawings / Dimensions	11
6. Packaging Information	12
Figure 1 Evaluation Board	3
Figure 2 Connectors Position / Resistor Functions	4
Figure 3 OCP Resistor Selection	5
Figure 4 UVLO Resistor Value Table	5
Figure 5 Output Trim Resistor Values	6
Figure 6 Remote Sense Connection	6
Figure 7 Hold Up Capacitor Values	7
Figure 8 EMI Schematic	8
Figure 9 EMI BOM	8
Figure 10 EMI Results	9

1. Introduction

MP-HW80EVAL-01 Evaluation Board User Guide

The MP-HW80EVAL-01 Evaluation Board is designed to assist with the evaluation of the IRH-W80, 250W, 10:1 input range DC/DC converter module from Murata Power Solutions. The IRH-W80 series of isolated regulated converter modules, deliver an impressive 250W single output from a wide input range of 16V – 160Vdc, complying with the input battery voltage transient range of EN50155.

The half brick module offers high efficiency levels up to 90%, with an input – output isolation voltage of 4242Vdc. The module features Overvoltage, Overcurrent, Short Circuit, Adjustable output voltage, Adjustable Current Limit, Positive or Negative Logic enable, Pulse output signal and Hold up function for an external capacitor. See Page 10 for full schematic.

Figure 1 – Evaluation Board

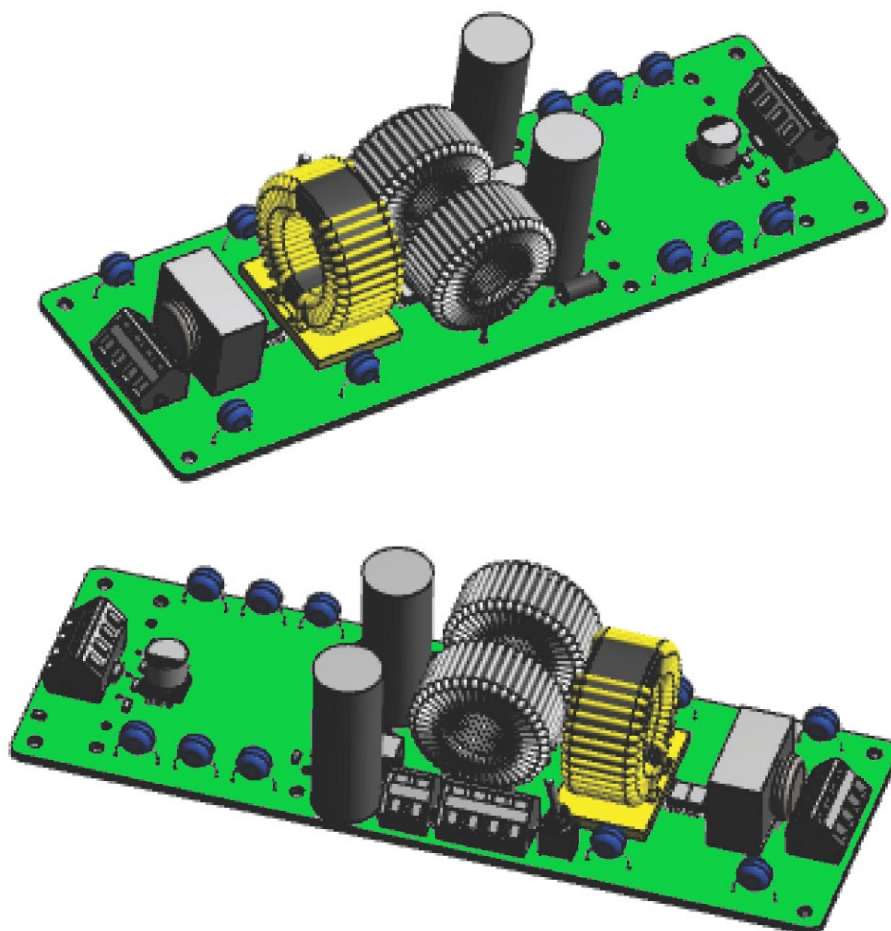

2. Setup

2.1 Connections

This section describes the connector locations/pinouts on the evaluation board, to enable correct set up.

Figure 2 - Connectors Position / Resistor Functions (Top View)

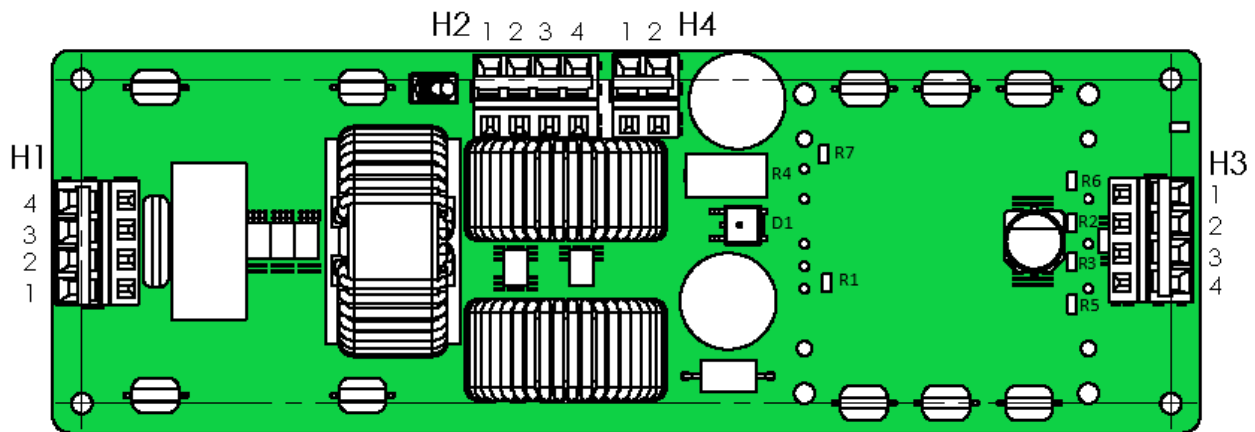

H1 Input Voltage Connector	
Pin 1	VIN-
Pin 2	VIN-
Pin 3	VIN+
Pin 4	VIN+

H2 Signal Connector	
Pin 1	PULSE
Pin 2	VIN-
Pin 3	ON/OFF
Pin 4	PE

Resistor / Function	
R1	UVLO
R2	TRIM DOWN
R3	TRIM UP
R4	CHARGE
R5	SENSE (+)
R6	SENSE (-)
R7	OCF

H3 Output Voltage Connector	
Pin 1	VOUT-
Pin 2	VOUT-
Pin 3	VOUT+
Pin 4	VOUT+

H4 External Hold Up Connector	
Pin 1	VIN-
Pin 2	CHOLD+

R1, R2, R3, R5, R6, R7 = SMD0805

2.2 On Board Component Values

2.2.3 OCP Resistor Value

R7 = OCP – Overcurrent Protection.

By adding a resistor SMD0805 to position R7 on the PCB, it is possible to set the overcurrent threshold point.

Leave unconnected if not used.

Figure 3 - OCP Resistor Selection

R7 OCP Value	562Ω	665Ω	845Ω	1.13kΩ	1.69kΩ	3.32kΩ	6.65kΩ	10kΩ	Open
24Vin	14.5A	16.2A	18.2A	20.2A	22.4A	24.3A	25A	25.5A	26A
48Vin	15.5A	17.4A	19.4A	21.1A	23A	24.5A	25.4A	25.9A	26.5A
72Vin	15.5A	17.4A	19.4A	21.1A	23A	24.5A	25.4A	25.9A	26.5A
110Vin	11.6A	14A	17.1A	19.8A	22.1A	24.5A	25.4A	25.8A	27A

2.2.4 Under Voltage Lockout. (UVLO)

By adding a SMD0805 resistor to R1 position as per the table below, the converter will shut down if the input voltage drops below the threshold. The converter will automatically restart when the input voltages rises above the UVLO threshold. Leave unconnected if not used.

Figure 4 - UVLO Resistor Value Table

Vin	24V	36V	48V	72V	96V	110V
Turn Off	10V-12V	17.5V-19.5V	26V-28V	40V-43V	56V-60V	65V-70V
Turn On	13V-15V	22V-24V	31V-34V	48V-51V	68V-72V	80V-84V
Resistor Value	Open	27.4kΩ	13kΩ	6.8kΩ	4.3kΩ	3.57kΩ

2.2.5 Output Voltage Trim Resistors

R3 and R2 – Trimming the Output Voltage.

The trim pin of the converter allows the user to adjust the output either +10% or -20% by using SMD0805 fixed value resistors.

Figure 5 - Output Trim Resistor Values

12V Output

Output Voltage	9.6V	10.8V	11.4V	12.6V	13.2V
R3 - Trim Up	NA	NA	NA	188kΩ	97kΩ
R2 - Trim Down	4kΩ	8.9kΩ	18.7kΩ	NA	NA

2.2.6 Sense Connections

If intended to utilize the output sense feature, please ensure that you short out, or add a zero ohm link in positions R5, Sense (+) and R6, Sense (-). If it is proposed to use the sense function, then please leave R5 and R6 open circuit, and connect output sense lines to the load. The sense connections can compensate up to 0.5V voltage drop of output leads.

Figure 6 - Remote Sense Connection

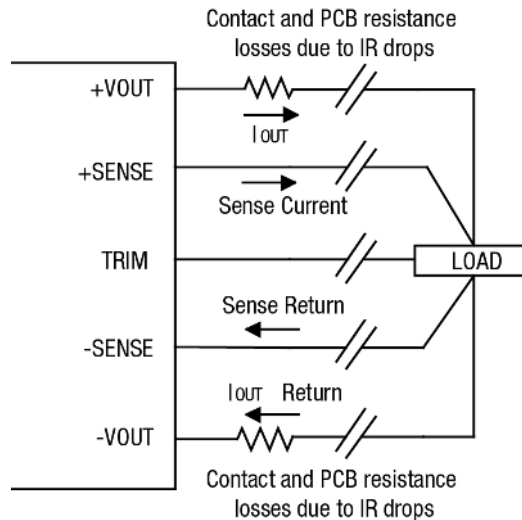

2.2.7 Hold Up Circuit

The BUS pin of the IRH250W80 module, is a voltage source output of 80Vdc to allow external capacitors to be connected in order to provide hold up power of the converter. The eval board houses a resistor (R4) to slowly charge the capacitors up, and a feed forward diode (D1) for rapid discharge into the module during hold up mode. The capacitor value can be as per the below table to provide 10msec or 20msec of hold up. Connect the capacitor to H4 Pin 1 = VIN-, Pin 2 = CHOLD+. As per Figure 2.

Figure 7 - Hold-Up Capacitor Values

Hold-up time	24Vin	36Vin	48Vin	72Vin	96Vin	110Vin
10ms	2200uF	2200uF	2200uF	2200uF	1100uF	700uF
20ms	4400uF	4400uF	4400uF	4400uF	2200uF	1400uF

2.2.8 External Fusing

The evaluation board does not have any fusing protection, the user must provide external fusing, circuit breaker protection as required.

2.2.9 Pulse Out

This pin outputs a 1kHz 50% duty cycle pulse voltage with 12V amplitude. It is designed to provide a bootstrap signal for the input inrush current limit circuit and could also indicate operating status with a LED connected. Leave unconnected if not used.

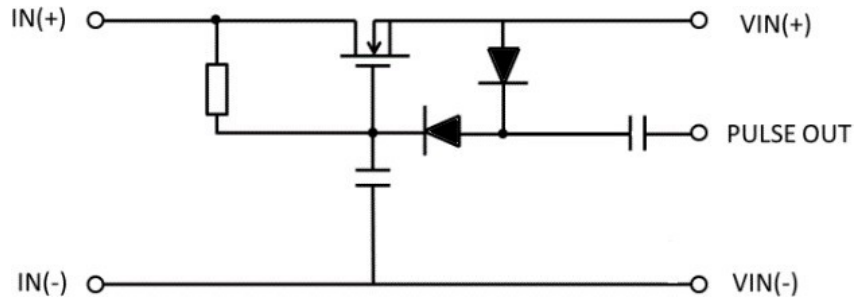

2.2.10 On/Off Control

Connect the On/Off pin (Pin 3, H2) to -VIN (Pin 2, H2) connection if “Negative” logic level is used in the part number of the IRH-W80. Leave the On/Off pin open if “Positive” logic level is used.

Note: A mechanical On/Off switch is also provided on the top side of the evaluation board.

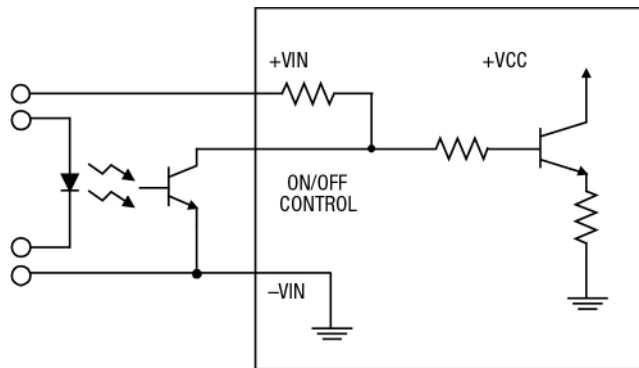

3. EMI Circuit

The following schematic below meets EN55011 Class A.

Figure 8 - EMI Schematic

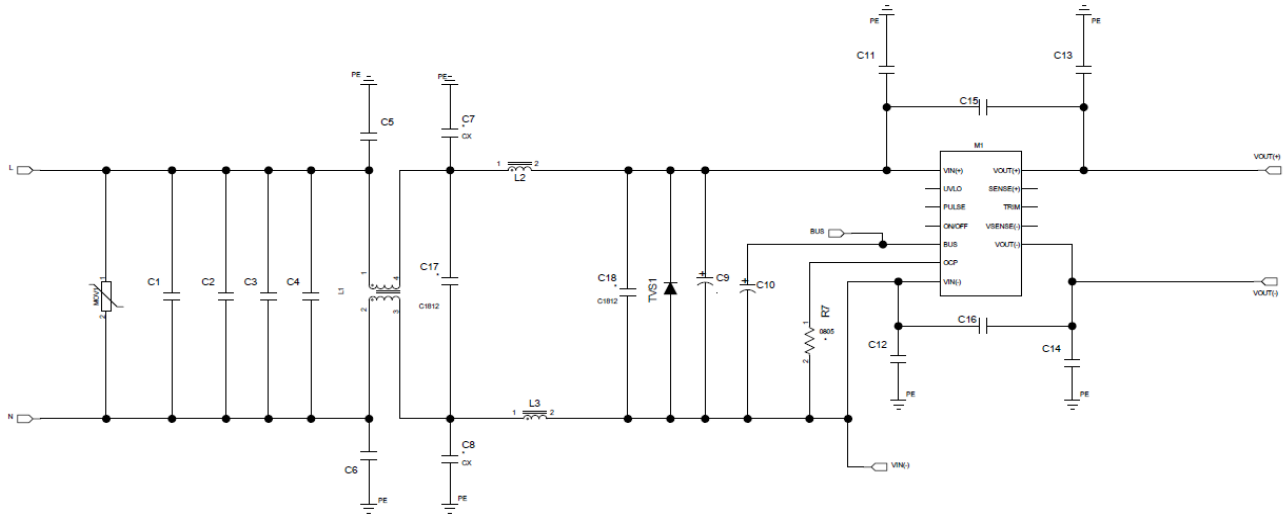

Figure 9 - EMI BOM

Reference	Manufacturer	MPN	Type	Specifications	Qty
MOV1	Epcos	B72214S0141K101	Varistor	180V, 36J	1
TVS1	Littel Fuse	1.5KE220A	TVS diode	185V, 1.5KW	1
C1	Faratronc	C212E475K9AC000	Polyester capacitor	250V, 4.7uF	1
C2, C3, C4	Murata	GRM43DR72E474KW01L	Capacitor MLCC	250V, 0.47uF	3
C5, C6, C11, C12, C13, C14	Murata	DE1E3RA102MA4BQ01F	Safety ceramic cap	500V, 1000pF	6
C9, C10	NCC	EKXJ251EXX271ML40S	E-cap	250V, 270uF	2
C15, C16	Murata	DE1E3RA472MA4BQ01F	Safety ceramic cap	500V, 4700pF	2
L1	Würth	7448262013	CM choke	1.3mH, 20A	1
L2, L3	Bourns	2300HT-220-V-RC1951	DM choke	22uH, 19A	2
C7, C8	NA	NOT USED	NA	NA	0
C17, C18	NA	NOT USED	NA	NA	0

Figure 10 - EMI Results

Limit Line as per EN55011 level A

Vin = 110V, Line L

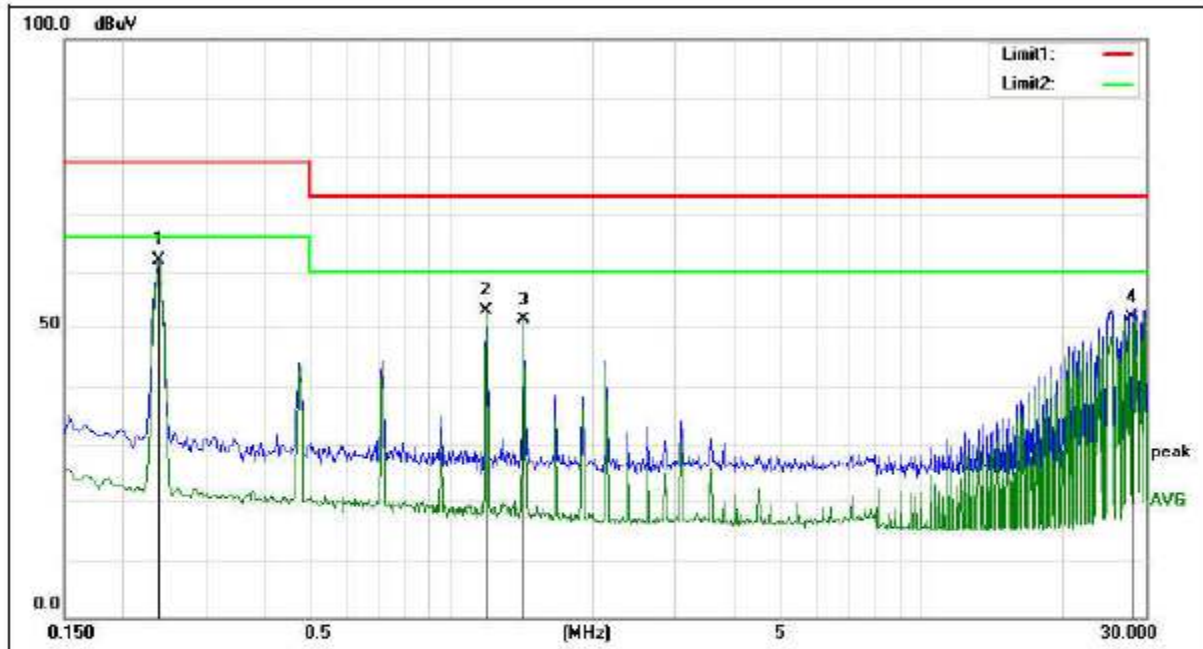

No.	Frequency (MHz)	Reading (dBuV)	Correct Factor(dB)	Result (dBuV)	Limit (dBuV)	Margin (dB)	Remark
1	0.2380	42.32	19.57	61.89	66.00	-4.11	AVG
2	1.1900	33.46	19.64	53.10	60.00	-6.90	AVG
3	1.4260	31.80	19.65	51.45	60.00	-8.55	AVG
4	28.0420	31.96	19.97	51.93	60.00	-8.07	AVG

4. Circuit Schematic

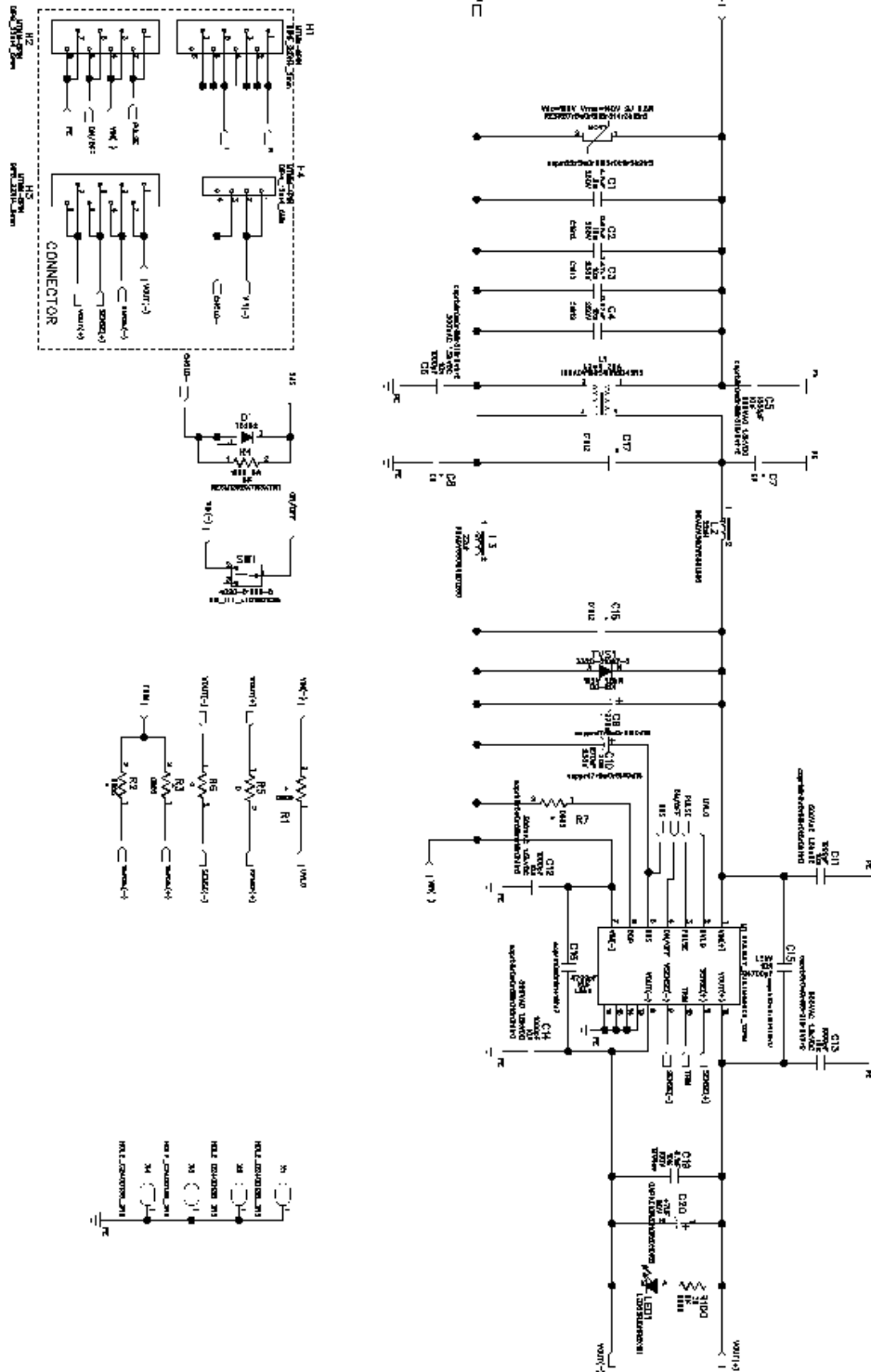

5. Mechanical Drawings / Dimensions

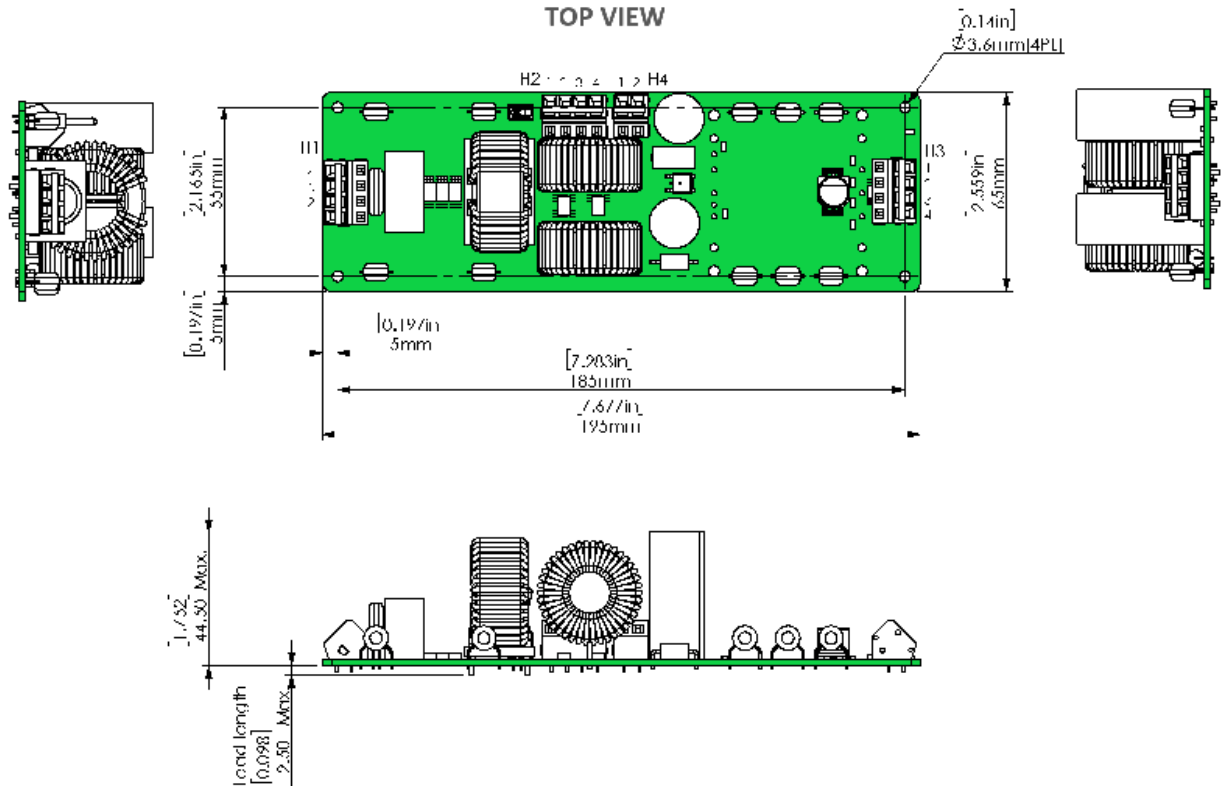

Connector	Pin number	Function
J1	1	VIN
	2	VIN
	3	VP
J2	1	PLUG
	2	VIN+
	3	VIN-
	4	FE
J3	1	VOLT
	2	VOLT
	3	VOLT
	4	VOLT
J4	1	VIN-
	2	CHOLD+

- NOTES:
 UNLESS OTHERWISE SPECIFIED:
 1: ALL DIMENSIONS ARE IN INCHES [MILLIMETER].
 2: ALL TOLERANCES:
 x.xxxin, ± 0.02 in (x.xxxxmm, ± 0.5 mm),
 x.xxxin, ± 0.01 in (x.xxxxmm, ± 0.25 mm).
 3: UNIT WEIGHT = 690 grams

6. Packaging Information

Item No.	Part Number	Description	Qty
1	2300214	Carton, 10'x 10'x4.45"	1
2	2300216	Pad, ESD Foam, 9.82" SQ, 1/4" Thk	1 (NOTE 8)
3	6256-01639-0	PACKING FOAM	2
4	2300159	Label, Paper, 1.0" x 1.5"	1
5	5600-01098-0	Label, ESD Warning	1
6	5652-01166-0	Label, Paper, Shipping 2" x 4"	1 (NOTE 6)
7	6200-01211-0	ESD Tape, 3/4" Wide	.33'

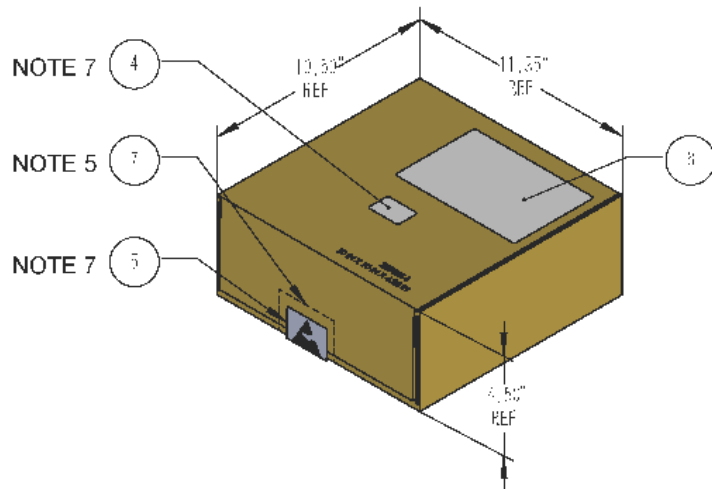
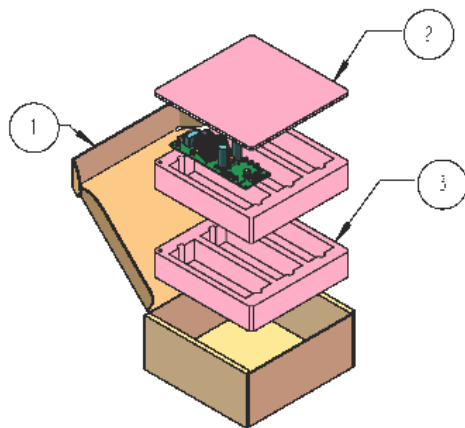

NOTES:

- THIS DOCUMENT DEFINES THE GENERAL PACKING RULES FOR THE APPLICABLE SHIPPING KIT. INFORMATION FOR SEALING AND MARKING IS NOT PART OF THIS DOCUMENT.
- REFER TO SHIPPING KIT BOM DETAILS.
- INSERT UNITS INTO FOAM POCKETS UB TRAYS APPROX AS SHOWN.
- EACH FOAM TRAY (6256-01639-0) CONTAINS 3 UNITS. IN FULL MPQ QUANTITIES, 2 TRAYS EQUAL TO A TOTAL OF 6 (2x3) UNITS PER BOX.
- FRONT FLAP SHALL BE SEALED WITH ESD TAPE SPECIFIED OR EQUIVALENT AFTER THE BOX IS CLOSED.
- LABEL (ITEM 6) USED FOR MFR OVERPACK CARTON.
- APPLY ESD LABEL (ITEM 5) OVER TAPE USED TO SEAL BOX AND APPLY IDENTIFICATION LABEL (ITEM 4) APPROX AS SHOWN.
- PAD (ITEM 2) MAY, AT MFR'S OPTION, BE EXCHANGED FOR THINNER PAD IF FOAM STACKUP EXCEEDS CARTON HEIGHT BY >1/8" OR ADDITIONAL PAD MAY BE ADDED IF STACKUP IS BELOW INSIDE CARTON HEIGHT BY > 1/8" ALTERNATE PADS: 1/4" THK=2300216, 3/8" THK=2300218, 1/2" THK=2300219, 3/4" THK=2300221.

Murata Power Solutions, Inc.
 129 Flanders Rd., Westborough, MA 01581 USA
 ISO 9001 and 14001 REGISTERED



This product is subject to the following [operating requirements](#) and the [Life and Safety Critical Application Sales Policy](#):

Refer to: <http://www.murata-ps.com/requirements/>

Murata Power Solutions, Inc. makes no representation that the use of its products in the circuits described herein, or the use of other technical information contained herein, will not infringe upon existing or future patent rights. The descriptions contained herein do not imply the granting of licenses to make, use, or sell equipment constructed in accordance therewith. Specifications are subject to changewithout notice.
 © 2021 Murata Power Solutions, Inc.