

Unipolar 2-Phase Stepping Motor Driver ICs

Features and Benefits

- Power supply voltage, V_{BB} , 46 V maximum; 10 to 44 V normal operating range
- Logic supply voltage, V_{DD} , 3 to 5.5 V
- Four output currents, $I_{O(max)}$, options: 1, 1.5, 2, and 3 A
- Stepping control for phase input (full or half step)
- Built-in sense resistor detects motor current
- Compact ZIP 23-pin molded package (SLA package)
- Self-excitation PWM control with fixed off-time
- Built-in synchronous rectifying circuit reduces losses at PWM-off
- Synchronous PWM function prevents noise generation in motor Hold mode
- Sleep function reduces power consumption of drivers in Standby mode
- Protection circuit detects motor coil open/short and prevents overheating due to avalanche breakdown
- Externally-adjustable ($3.2 \mu s/5.2 \mu s$) blanking time (minimum on-time)

Package: 23-pin ZIP (type SLA)



Not to scale

Description

This document describes the function and features of SLA7080M series, which are unipolar 2-phase stepping motor driver ICs. Four levels of output current are available from the incorporated MOSFETs, corresponding to the rated output current ratings. All current ratings are available with protection against motor coil shorts or motor open wire detection.

The SLA7080M series has a multichip structure, for enhanced thermal dispersion. The Control IC (MIC), four power elements (MOSFET), and dual sense resistors, are all separate ICs.

Built-in sense resistors for each phase allow accurate tracking of performance without additional external components. Low-power sleep mode as well as reduced power during PWM off-time maximize energy savings.

Functional Block Diagram

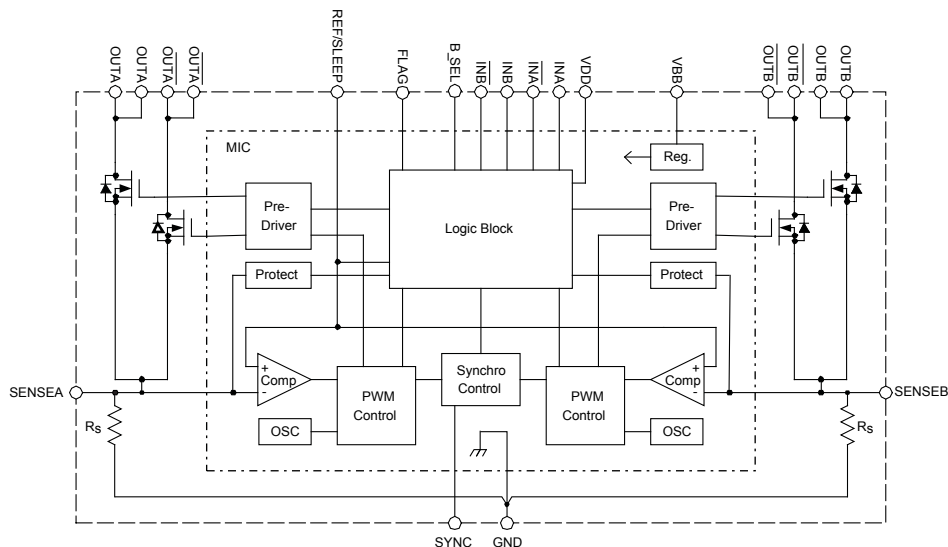

Selection Guide

Part Number	Output Current (A)	Built-In Sense Resistor	Packing
SLA7080MPR	1	Yes	18 pieces per tube
SLA7081MPR	1.5		
SLA7082MPR	2		
SLA7083MPR	3		

Absolute Maximum Ratings, valid at $T_A = 25^\circ\text{C}$

Characteristic	Symbol	Notes	Rating	Unit
Motor Supply Voltage	V_M		46	V
Main Supply Voltage	V_{BB}		46	V
Logic Supply Voltage	V_{DD}		6	V
Output Current	I_O	SLA7080MPR	1.0	A
		SLA7081MPR	1.5	A
		SLA7082MPR	2.0	A
		SLA7083MPR	3.0	A
Logic Input Voltage	V_{IN}		-0.3 to $V_{DD} + 0.3$	V
REF Input Voltage	V_{REF}		-0.3 to $V_{DD} + 0.3$	V
Allowable Power Dissipation	P_D	No heatsink	4.7	W
Maximum Junction Temperature	$T_{J(max)}$		150	$^\circ\text{C}$
Nominal Operating Temperature	T_A		-20 to 85	$^\circ\text{C}$
Storage Temperature	T_{stg}		-30 to 150	$^\circ\text{C}$

Recommended Operating Range

Characteristic	Symbol	Notes	Min	Max	Unit	
Motor Supply Voltage	V_M		-	44	V	
Main Supply Voltage	V_{BB}		10	44	V	
Logic Supply Voltage	V_{DD}	V_{DD} surge voltage = ± 0.5 V	3.0	5.5	V	
Case Temperature	T_C	Without heatsink	On pin 12, adjacent to case	-	90	$^\circ\text{C}$
		With heatsink		-	80	$^\circ\text{C}$

All performance characteristics given are typical values for circuit or system baseline design only and are at the nominal operating voltage and an ambient temperature, T_A , of 25°C , unless otherwise stated.

ELECTRICAL CHARACTERISTICS valid at $T_A = 25^\circ\text{C}$, $V_{BB} = 24\text{ V}$ and $V_{DD} = 5\text{ V}$, unless otherwise noted

Characteristics	Symbol	Conditions	Min	Typ	Max	Units
Main Supply Current	I_{BB}	In operation	–	–	15	mA
	I_{BBS}	Sleep state	–	–	100	μA
Logic Supply Current	I_{DD}		–	–	5	mA
Output MOSFET On-Resistance	$R_{DS(on)}$	SLA7080MPR	–	0.7	0.85	Ω
		SLA7081MPR	–	0.45	0.6	Ω
		SLA7082MPR	–	0.25	0.4	Ω
		SLA7083MPR	–	0.18	0.24	Ω
Output MOSFET Diode Forward Voltage	V_F	SLA7080MPR	–	0.85	1.1	V
		SLA7081MPR	–	1.0	1.25	V
		SLA7082MPR	–	0.95	1.2	V
		SLA7083MPR	–	0.95	2.1	V
Output MOSFET Breakdown Voltage	V_{DSS}	$V_{BB} = 44\text{ V}$, $I_D = 1\text{ mA}$	100	–	–	V
Maximum Response Frequency	f_{clk}	Clock duty cycle = 50%	250	–	–	kHz
Logic Input Voltage	V_{IL}		–	–	$V_{DD} \times 0.25$	V
	V_{IH}		$V_{DD} \times 0.75$	–	–	V
Logic Input Current	I_{IL}		–	± 1	–	μA
	I_{IH}		–	± 1	–	μA
REF Input Voltage	V_{REF}	SLA7080MPR	0.04	–	0.3	V
		SLA7081MPR, SLA7083MPR	0.04	–	0.45	V
		SLA7082MPR	0.04	–	0.4	V
	V_{REFS}	Sleep state (output off)	2.0	–	V_{DD}	V
REF Input Current	I_{REF}		–	± 10	–	μA
SENSE Detect Voltage	V_{SENSE}		$V_{REF} - 0.03$	V_{REF}	$V_{REF} + 0.03$	V
Sense Resistor ¹	R_s	SLA7080MPR, SLA7081MPR	0.296	0.305	0.314	Ω
		SLA7082MPR	0.199	0.205	0.211	Ω
		SLA7083MPR	0.150	0.155	0.160	Ω
PWM Minimum On-Time (Blanking Time)	$t_{on(min)}$	B_SEL = low	–	3.2	–	μs
		B_SEL = high	–	5.2	–	μs
PWM Off-Time	t_{off}		–	13	–	μs
Sleep Enable Recovery Time	t_{SE}	Sleep state	100	–	–	μs
Switching Time	t_{don}	Phase INx → Phase OUTx on	–	1.5	–	μs
	t_{doff}	Phase INx → Phase OUTx off	–	1.0	–	μs

Continued on the next page...

ELECTRICAL CHARACTERISTICS (continued) valid at $T_A = 25^\circ\text{C}$, $V_{BB} = 24\text{ V}$ and $V_{DD} = 5\text{ V}$, unless otherwise noted

Characteristics	Symbol	Conditions	Min	Typ	Max	Units
Protection Functions²						
Overcurrent Detect Voltage	V_{OCP}	At motor coil short circuit	0.65	0.7	0.75	V
Overcurrent Detect Current (V_{OCP}/R_S)	I_{OCP}	SLA7080MPR, SLA7081MPR	–	2.3	–	A
		SLA7082MPR	–	3.5	–	A
		SLA7083MPR	–	4.5	–	A
Delay to Open Load Detect	t_{OPP}		1.5	2.0	2.5	μs
Overtemperature Protection Threshold Temperature	T_{TSD}	Measured at back surface of device case; device operating such that self-generated heat has permeated detection circuits on MIC; see Thermal Design section	–	140	–	$^\circ\text{C}$
FLAG Output Voltage	V_{FLAGL}	$I_{FLAGL} = 1.25\text{ mA}$	–	–	1.25	V
	V_{FLAGH}	$I_{FLAGH} = -1.25\text{ mA}$	$V_{DD} - 1.25$	–	–	V
FLAG Output Current	I_{FLAGL}		–	–	1.25	mA
	I_{FLAGH}		-1.25	–	–	mA

¹External sense resistor value approximately 5 m Ω in addition to value of built-in resistor.

²Protection circuit operates when $V_{SENSE} \geq V_{OCP}$.

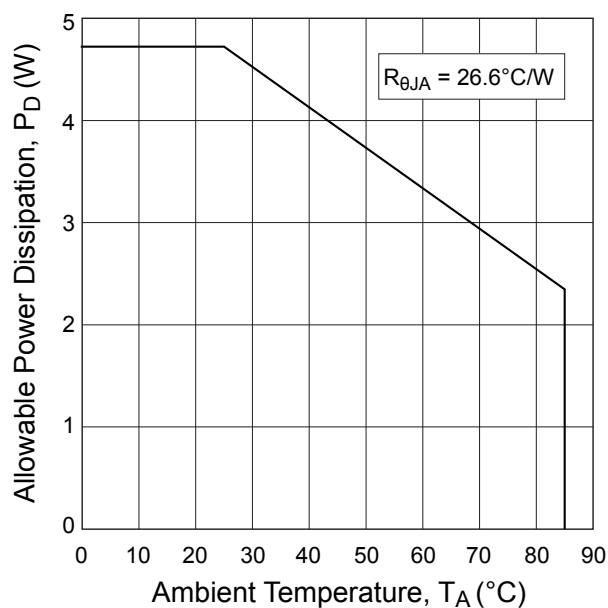
Power Derating Chart

Performance Characteristics at $T_A = 25^\circ\text{C}$

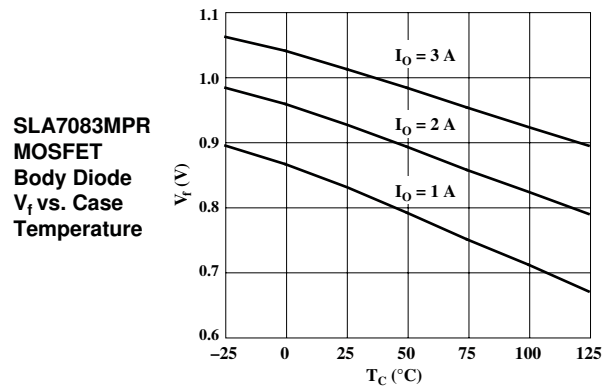
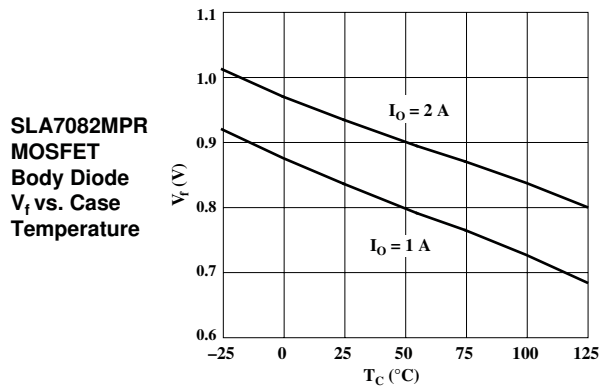
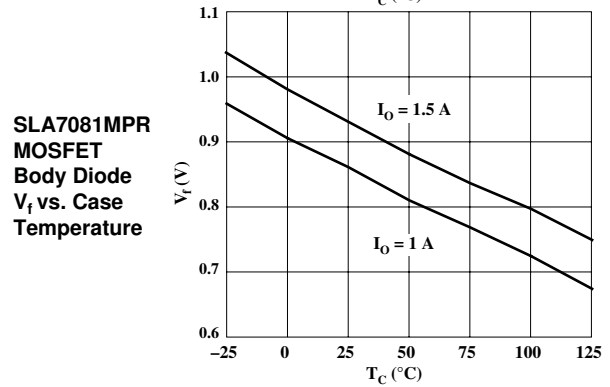
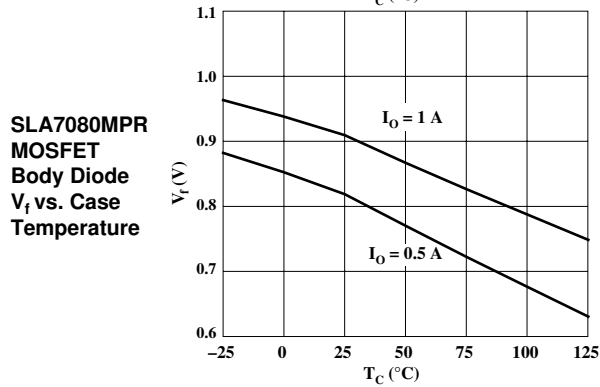
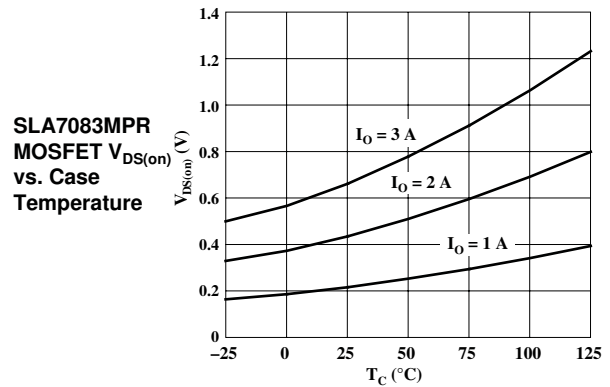
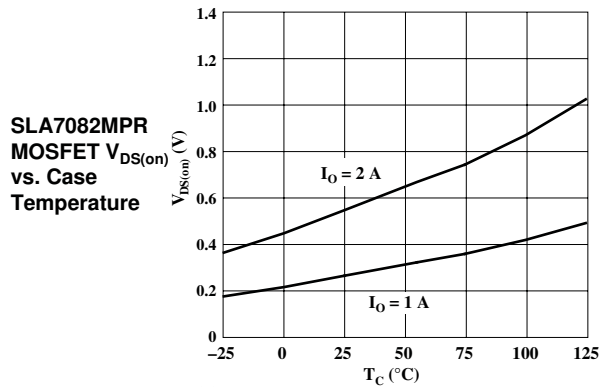
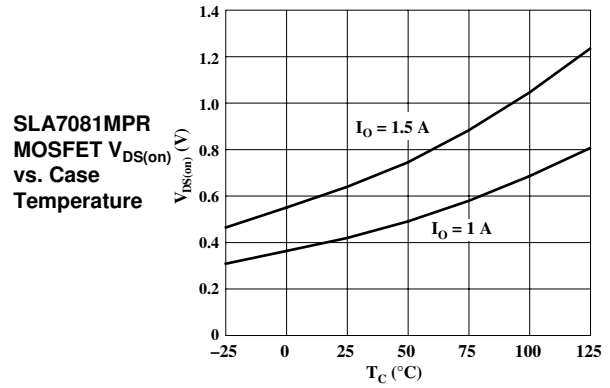
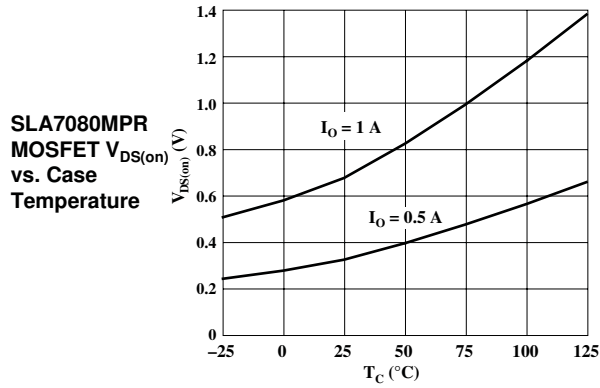

Functional Description

Logic Block

This circuit block is integrated on the Control IC (MIC). It operates by the logic power supply, V_{DD} , and propagates signals to each circuit block in accordance with the logic input signals.

Regulator Circuit

This circuit block is integrated on the Control IC (MIC). The integrated regulator circuit is used in driving the output MOSFET gates and in powering other internal linear circuits.

Dual Phase Output Control

The SLA7080M series allows dual phase operation based on external input to the INx pins. The phase-switching logic is shown in the following table:

		Phase A [B]	
INA [INB]	$\overline{\text{INA}} [\overline{\text{INB}}]$	OUTA [OUTB]*	$\overline{\text{OUTA}} [\overline{\text{OUTB}}]^*$
Low	Low	OFF	OFF
High	Low	ON	OFF
Low	High	OFF	ON
High	High	OFF	OFF

*OUT indicates power MOSFET drain state (does not indicate PWM operation)

PWM Control

This circuit block is integrated on the Control IC (MIC). This is the main circuit block for pulse width modulated (PWM) control of self-excitation and external excitation for motor driving. An illustration of PWM behavior is shown in figure 1.

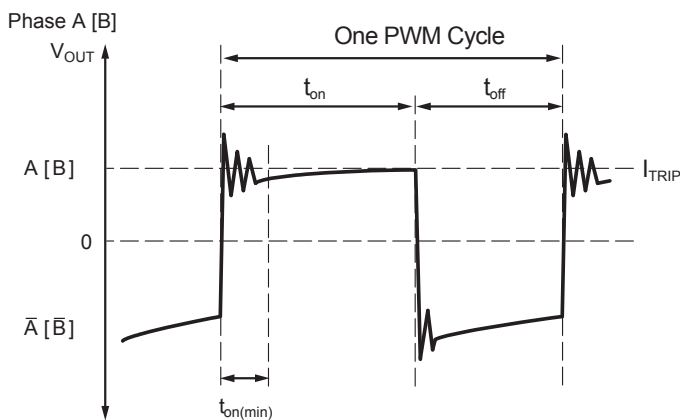

Figure 1. PWM waveform on SLA7080M sense resistor, R_S ; t_{off} is fixed and the blanking time, $t_{off(min)}$, is dynamically selectable.

PWM control mode is set by the SYNC pin. Set SYNC to logic high for synchronous PWM, and set it to logic low for asynchronous PWM.

PWM Off-Time, t_{off} , (for self-excitation), minimum off-time (for external excitation), and PWM Minimum On-Time (blanking time), $t_{on(min)}$, are clocked by means of the built-in oscillator.

The length of t_{off} is fixed internally. Like in the SLA7070M series, the SLA7080M series has a power-saving function that reduces power consumption during t_{off} . This function recirculates electromotive force that is stored in the motor coil while the power MOSFETs are turned on.

The time interval during which the output MOSFETs are on is t_{on} . The minimum duration for the PWM Minimum On-time, $t_{on(min)}$, is effectively the blanking time selected, even if the application attempts to shorten t_{on} in order to limit current. The minimum coil current is at $t_{on(min)}$, so when the coil current is limited at power-down or other events, it can be no shorter than the blanking time.

Blanking Time

The blanking time function is provided to limit current in order to suppress ringing immediately after PWM turns on, and to improve current control tracking. Blanking time in effect determines PWM Minimum On-Time, $t_{on(min)}$. The length of the blanking time is selected by the B_SEL pin. Set B_SEL to logic high for 3.2 μs blanking time, and set it to logic low for 5.2 μs .

Some ringing is generated for a few microseconds after PWM switching (see figure 2). Ringing can result from various causes, such as capacitance between motor cells, or inappropriate motor wiring. To suppress this behavior, the blanking time selection sets a minimum time interval during which current detection signals from the current sense comparators are ignored after a PWM switch-on.

Current control (tracking) in the SLA7080M series is regulated by comparing the detection voltage on the sense resistor, V_{RS} , with the reference voltage, V_{REF} . If the ringing noise causes V_{RS} to exceed V_{TRIP} , the comparator is activated and PWM turns off.

Current control performance at shorter PWM waveforms can be improved by shortening the blanking time, but this decreases the effectiveness of ringing suppression, resulting in the seeking behavior shown in figure 3.) To solve this problem, the SLA7080M series is designed to allow dynamic selection of blanking time duration. In the event that the seeking behavior

occurs when the short blanking time is selected, the problem may be eased by the selection of the longer blanking time.

A comparison of these trade-offs is provided in the following table (comparisons assume that operating conditions other than the SLA7080M, such as motors, motor power supply voltage, REF input voltages and so forth, as well as circuit constants, are identical in each case).

Parameter	Better Performance
Internal Blanking Set Time	Short or Long
Minimize PWM On-time (minimum)	Short
Maximize Ringing Noise Suppression	Long
Minimize Coil Current	Short

Synchronous Control

The SLA7080M series has a chopping synchronous function to prevent noise which may occasionally be generated during the motor Hold state. This function can be operated by setting the SYNC pin to logic high, which generates a timing signal to synchronize the chopping of the A and B phases. (This function operates identically to that of the SLA7070M.)

This function should be used only during self-excitation PWM control. The use of synchronous control during normal stepping motor rotation is not recommended because it produces less motor torque or may cause motor vibration because the control current does not stabilize.

Protection Circuit

A built-in protection circuit detects against motor coil opens and shorts. Operation of the protection circuit disables all of the out-

puts, and sets the FLAG pin. To leave protection mode and return to normal operation, cycle the logic power supply, V_{DD} .

Protection is activated by sensing voltage on the internal sensing resistors, R_S . Overcurrent that flows without passing the sense resistors cannot be detected. Therefore, this does not detect an overcurrent condition resulting from the OUT pins or SENSE pins shorting to GND.

Protection against motor coil opens is available only during PWM operation. Therefore, it does not work during constant voltage driving, when the motor is rotating at high speed.

Motor Coil Short Circuit Protection (Load Short Circuit)

This function operates by detecting voltage V_{RS} on the internal sense resistors in the same manner as the current control function. The threshold voltage, V_{OCP} , is set to 0.7 V typical. When V_{RS}

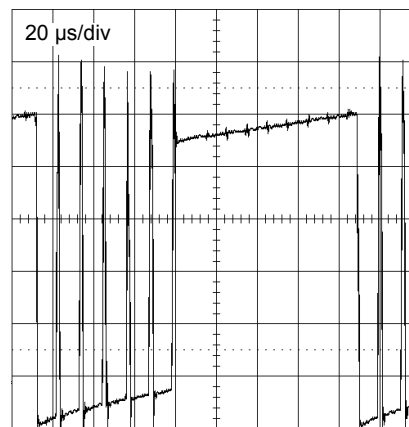

Figure 3. PWM waveform exhibiting seeking behavior

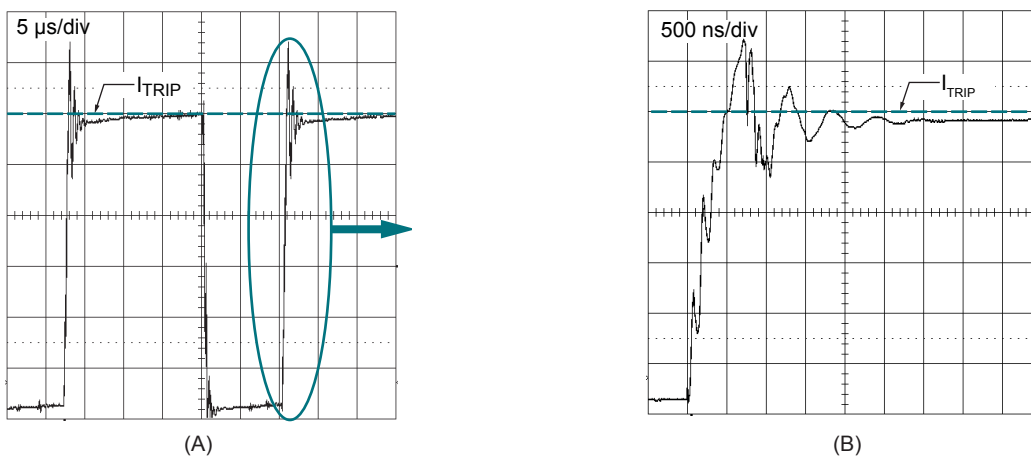

Figure 2. Ringing on PWM waveform while driving a motor. The circled area in panel A is expanded in time and shown in panel B.

$> V_{OCP}$ the motor coil short-circuit protection starts its operation. Coil short circuit and the protection circuit behavior are illustrated in figure 4.

Motor Coil Open Protection (Load Open Circuit) (Patent pending.)

This function operates by detecting polarity reversal of voltage V_{RS} on the internal sense resistors. After the state is confirmed, the device shuts down the outputs. This allows detection of a wire of the motor coil breaking. Coil open circuit and the protection circuit behavior are illustrated in figure 5.

In a unipolar topology, an undetected broken wire on an output pin (motor coil), can cause destruction of the driver due to overheating. This is because after the wire breaks, the connected driver MOSFET repeatedly undergoes avalanche breakdown at PWM turn-off, due to the higher energy applied from back electromagnetic force, as the energy stored in the motor coil is dissipated. Avalanche breakdown occurs when the output voltage surpasses the breakdown voltage between the drain and source of

the MOSFET. Although the MOSFETs in the SLA7080M series have an ample avalanche breakdown rating for rated operating temperatures, the avalanche breakdown rating decreases as the operating temperature rises (as avalanche breakdown is repeated). When the SLA7080M series protection circuit detects avalanche breakdown, it allows the breakdown to repeat 3 times to prevent false detections and then turns off the MOSFET outputs before overheating can occur.

The detection function operates as follows. When the wire of the motor coil is broken, the regenerating current that can reach the MOSFET breakdown level flows during the PWM off-time. Although the detection voltage, V_{RS} , has negative potential in normal operation, when a wire breaks in the motor coil, positive potential appears during a PWM off-time. That is to say, wire breakage in the motor coil can be detected, when V_{RS} is detected with positive potential during PWM off-time.

In addition to requiring three breakdown cycles to confirm the

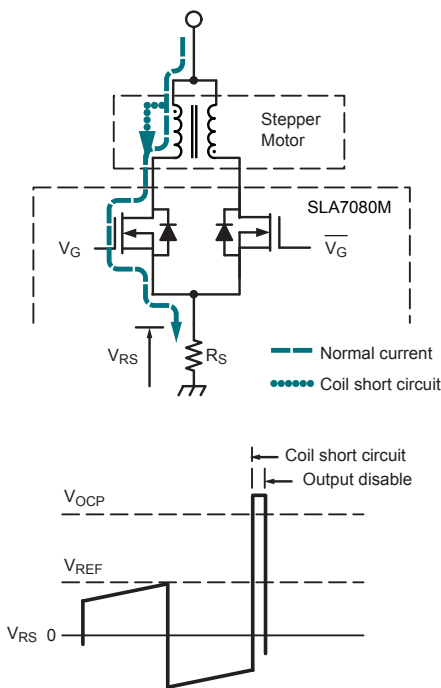

Figure 4. Motor coil short circuit protection operation

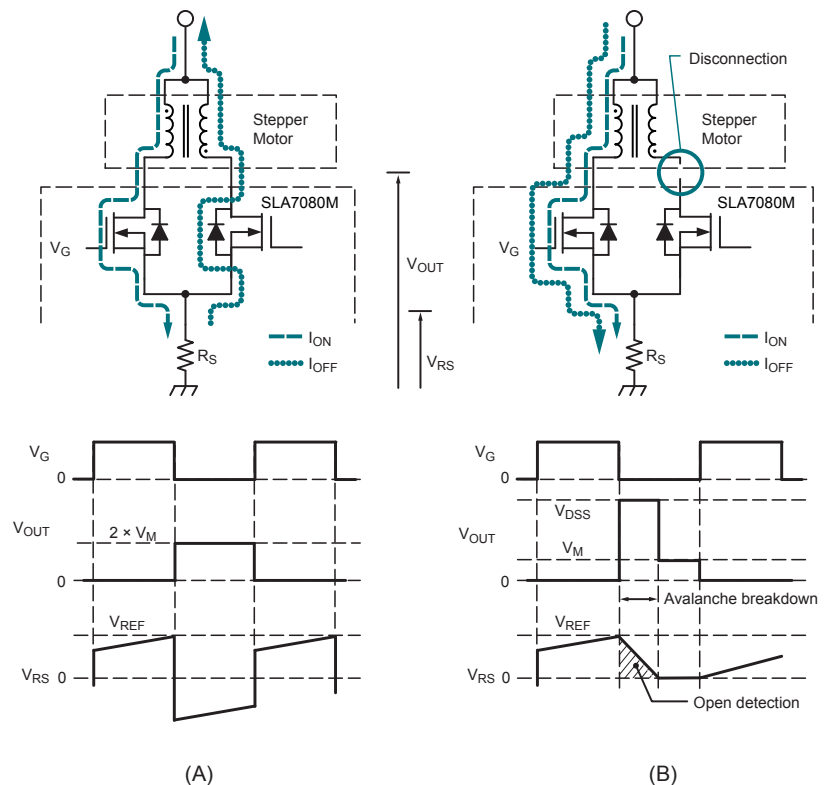

Figure 5. Motor coil open circuit protection in unipolar configuration, (A) PWM normal operation, (B) PWM operation with motor partially disconnected or broken wire in coil; V_M is the motor control voltage

open circuit condition, the SLA7080M protection function also provides a fixed delay, t_{OPP} , before the device shuts down the outputs. This is to avoid false detections based on ringing after PWM turn-off. Referring to figure 6, if the breakdown confirmation interval (3 breakdown cycles) plus ringing effects are shorter than t_{OPP} , the protection circuit functions correctly. However, if ringing causes the total period to exceed t_{OPP} , false detections can occur. If this is the case, check the motor and wiring layout to reduce ringing. Variation among device variants and applications should be taken into consideration. One possible solution is the addition of a capacitor between the OUTx and GND pins, which could damp the ringing sufficiently to allow continuation of normal operation when there is no actual avalanche breakdown.

Synchronous Rectification

A dead time, approximately 0.5 μ s, is set to prevent simultaneous turn-on of the MOSFETs at switching during synchronous rectification. During the dead time, the regenerating current flows through the body diode on each MOSFET chip, as shown in figure 7.

Power Supply

There is no restriction on the on/off sequencing of the main power supply, V_{BB} , and the logic supply, V_{DD} . Because the SLA7080M series has a structure that separates the Control IC (MIC) with the power MOSFET of the output stage, the motor power supply and the main power supply are electrically separated. Therefore, it is possible to drive the device by using different voltages for motor power supply and main power supply. Note that the power supplies have different voltage ranges.

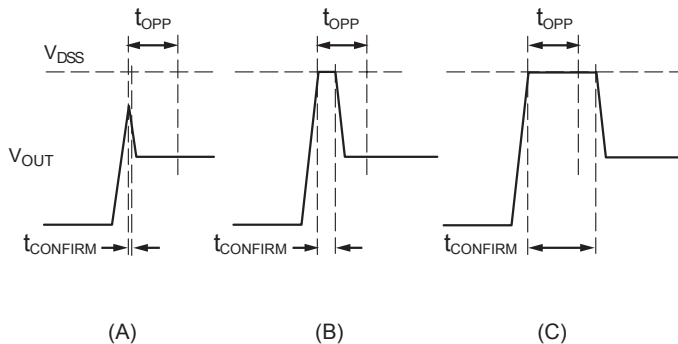

Figure 6. Alternative t_{OPP} scenarios: (A) no ringing, breakdown confirmed after three cycles, (B) ringing plus three cycles is less than t_{OPP} with no effect on operations, and (C) ringing is greater than t_{OPP} generates false detections of breakdowns

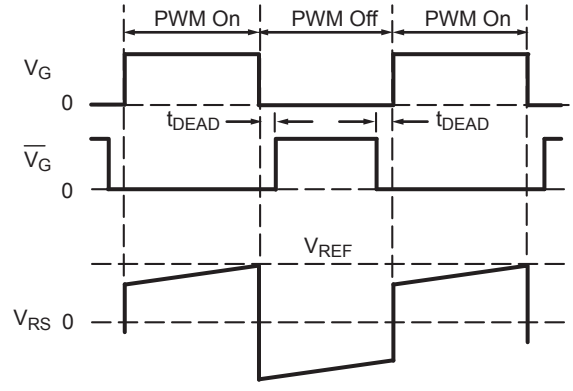
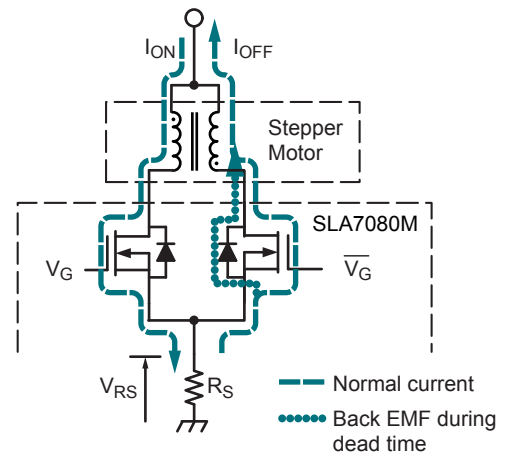

Figure 7. Synchronous rectification operation

Application Information

INA, $\overline{\text{IN}}\overline{\text{A}}$, INB, $\overline{\text{IN}}\overline{\text{B}}$, B_SEL, and SYNC pins

These inputs operate with CMOS input. The default state is high impedance, and they must be driven to logic high or logic low. When these logic input pins are used, they should be pulled down to the ground side using a 1 to 10 k Ω resistor. Any of these pins that are not used must either be pulled up to the V_{DD} side or be pulled down to the ground side.

If they are left open, malfunction or permanent damage to the product may result. For example, in case the signal from the microcomputer has high impedance, a pull-down or pull-up resistor should be provided. In particular, when an IN_x pin is in high impedance during operation, abnormal oscillation of the output may be caused and in the worst case, this will result in permanent damage to the MOSFETs.

A low pass filter (LPF) is provided on each the logic input pin. These improve noise filtering.

Sleep Mode

The SLA7080M can be set into Sleep mode, in which the motor is not controlled, so it can move freely. To enable Sleep mode, set the REF pin at more than 2 V. In Sleep mode, the device stops the main power supply and decreases circuit current.

When shifting the device directly from the Sleep mode to the normal operating mode (motor rotation), not only the rise time of the device, but also the rise time of motor excitation current should be considered when determining the amount of time lag from the cancellation of Sleep mode to the next motor phase input command. As shown in figure 8, a minimum lag of 100 μs is recommended.

Because of the built-in circuit protection features, be cautious about taking too long when switching between the Motor Current Setting range and the Sleep Limit range (refer to figure 9).

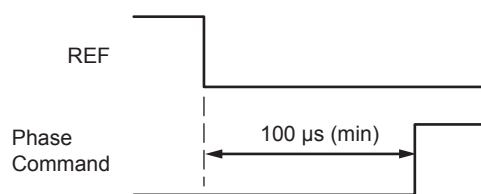

Figure 8. External circuit for detecting phase control signals

Because the V_{OCP} level occurs in the Prohibited range, between those two areas, if the switching time is too lengthy, overcurrent protection will start operating when V_{SENSE} > V_{OCP}.

FLAG pin

This is the output for the protection circuit:

FLAG Pin Output Logic	
Low	Normal operation
High	Protection circuit operation

It is designed for CMOS output, as shown in the equivalent circuit in figure 10. Therefore, if the FLAG logic pin is not used, it must be left open.

Internal Sense Resistors, R_S

Sense resistors which detect motor currents are incorporated in this product series. The values of the internal sense resistors, R_S, can be calculated (for the standard SLA7080M variants listed in this document) by applying the power loss formula:

$$P \approx I_O^2 \times R_S .$$

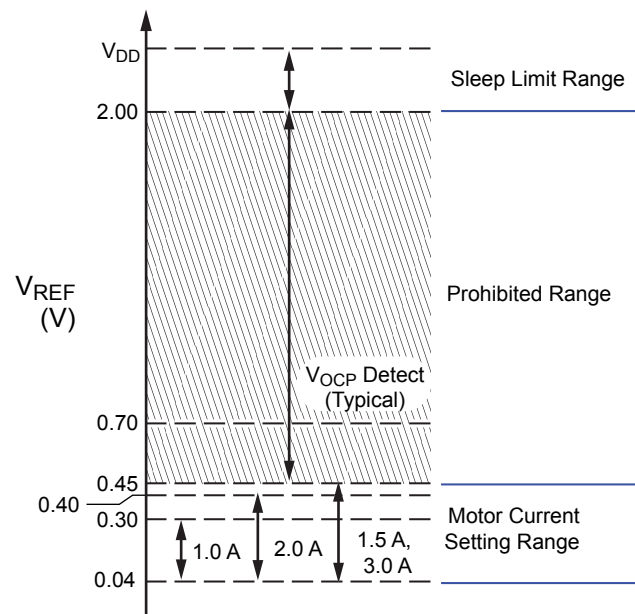

Figure 9. Reference voltage, V_{REF}, ranges

The resistance value of the incorporated resistors varies according to the rated currents.

Rated Current (A)	Detected Resistance Value (Ω Typical)
1	0.305
1.5	0.305
2	0.205
3	0.155

Each resistance value shown above includes the inherent resistance (approximately 5 mΩ) in the SLA7080M due to product structure.

In particular, be cautious about noise on the VDD line. When the noise on VDD line exceeds 0.5 V, device malfunction may be caused. To avoid this, special attention should be paid to the layout of the ground circuits. The separation of the VDD ground and the VBB ground from the product GND pin is effective in reducing the noise.

Clocking Switch Signals

In normal operation, the input signal for switching is received from an external microcomputer into the INx pins. However, in an application where the signal cannot be input, for example, due to the limitation of ports, this function can be performed using the following method. Refer to figure 11, which illustrates a topology for a synchronization signal generation circuit that uses clock signals.

When a logic high level signal is input to the circuit, the capacitor in the circuit is charged and the SYNC signal is set to logic low level in the SLA7080M.

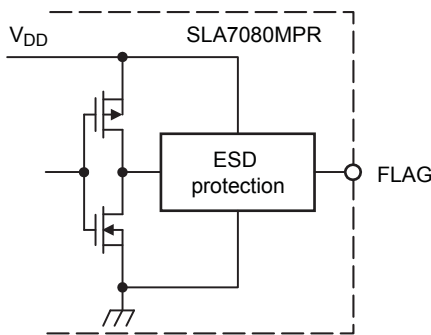

Figure 10. FLAG pin equivalent circuit

When the clock signal is stopped at low level, the capacitor is discharged by the resistor and the SYNC signal is set to logic high, causing the SLA7080M to shift to the synchronous mode.

The RC time constant should be determined by the minimum clock frequency used. In the case of a sequence that keeps the clock input signal at logic high, an inverter circuit must be added.

Setting Motor Currents for Constant Running

In the SLA7080M series the motor current level, I_O, is determined by the internal sense resistors, R_S, and the values selected for the external components R1 and R2 (see figure 12).

I_O is calculated by the following formulas:

$$V_{REF} = \frac{R_2}{R_1 + R_2} \times V_{DD} \tag{2}$$

$$I_O = \frac{V_{REF}}{R_S} \tag{3}$$

If V_{REF} is set below 0.04 V, the accuracy of I_O setting is highly likely to be degraded due to the variation between individual devices and the impedance of the application trace layout.

Lower Limit of Motor Current Control

The SLA7080M series uses a self-excitation PWM current control system with the fixed PWM off-time, t_{off}. When the energy stored in the motor coil is dissipated in less than t_{off}, the coil current flows as an intermittent current as shown in figure 13. That is to say, the PWM average current is decreased and the motor torque is lowered. When the current begins to flow in the coil intermittently, this state is considered the lower limit of the current control, I_O(min).

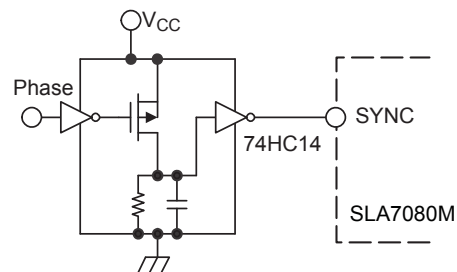

Figure 11. External circuit for detecting phase control signals

The lower limit of the control current varies subject to application conditions, such as the motors used, but it can be calculated by the following formula:

$$I_{O(\min)} = \frac{V_M + R_{DS(on)} \times I_O}{R_M} \times \left[\frac{1}{\exp\left(-\frac{t_{off}}{T_c}\right)} - 1 \right] \quad (2)$$

Where:

T_c is L_M / R_M ,

V_M is the motor supply voltage,

I_O is the set current value,

L_M is the motor winding inductance,

$R_{DS(on)}$ is the MOSFET on-resistance,

R_M is the motor winding resistance, and

t_{off} is the PWM of -time.

Even if the set control current, I_O , is set at less than the calculated $I_{O(\min)}$, there is no harmful effect on the SLA7080M devices, but the control current will worsen against set current.

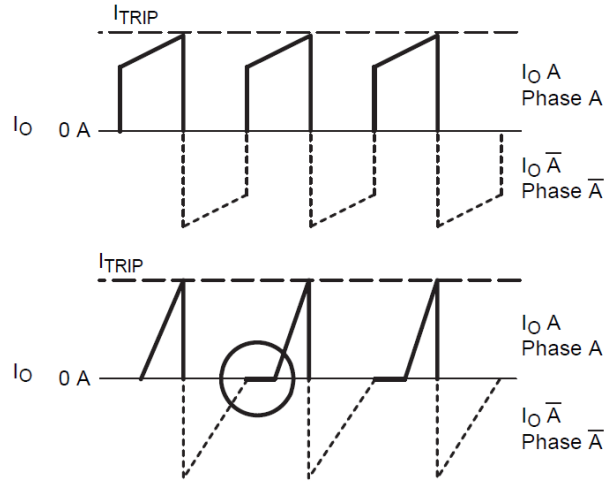

Figure 13. Motor current lower limit typical waveforms; circled area indicates interval when 0 A coil current is generated

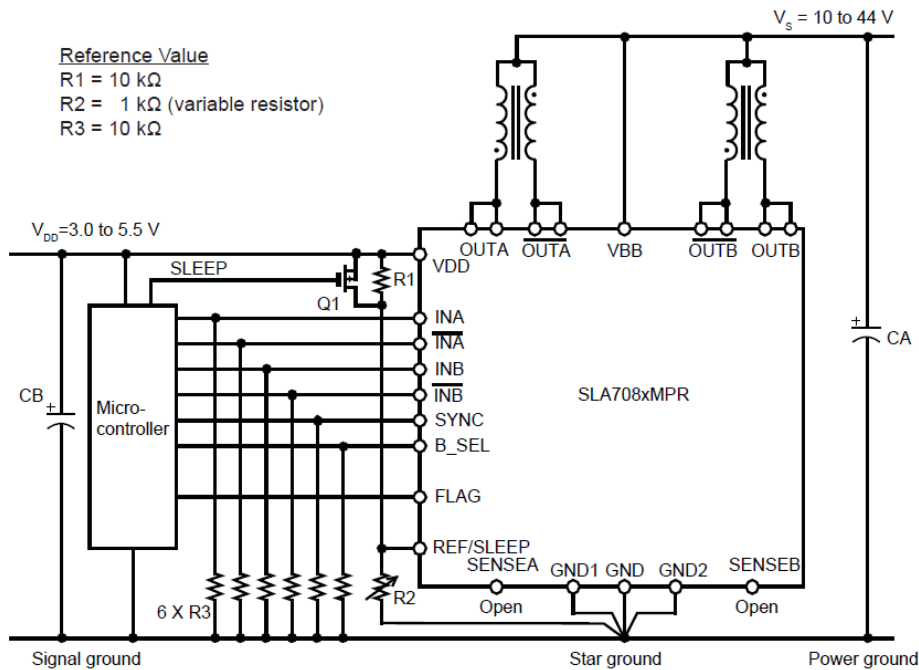

Figure 12. Typical application circuit using SMA7080MPR

Verification of Avalanche Energy

Due to the unipolar topology of the SLA7080M series, a surge voltage (ringing) that exceeds the MOSFET breakdown voltage might be applied to the device. In anticipation of this surge voltage, the SLA7080M series uses MOSFETs having sufficient avalanche resistance to withstand such surge voltages. Therefore, even if a surge voltage occurs, users will be able to use the device without any problem.

However, if the motor wiring harness is long or the SLA7080M is used at greater than the rated current or voltage, an avalanche energy beyond our design expectations may be applied to the device. Thus, users must test the avalanche energy applied to the device under actual application conditions.

The following procedure can be used to check the avalanche energy in an actual application. The following typical values

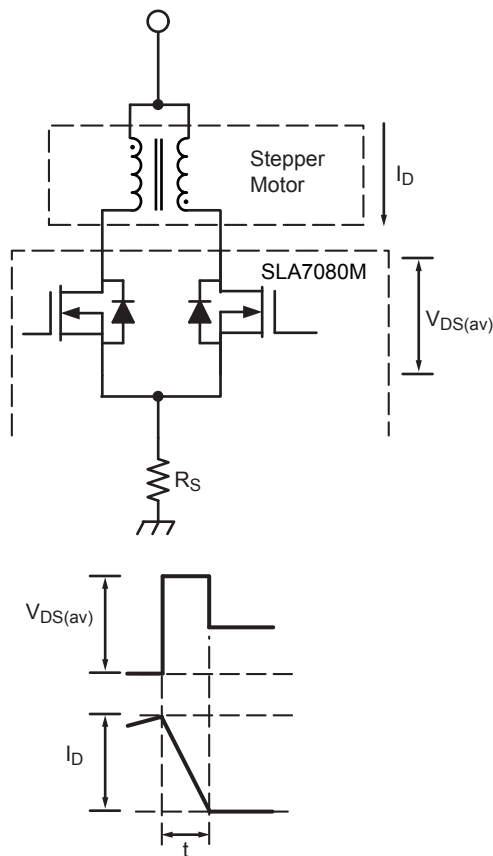

Figure 14. Test points and waveform for testing avalanche energy of an application

result from testing (refer to figure 15):

$$V_{DS(av)} = 140 \text{ V}$$

$$I_D = 1 \text{ A}$$

$$t = 0.5 \mu\text{s}$$

The avalanche energy, E_{AV} , is obtained by substituting values into the following formula:

$$E_{AV} \approx V_{DS(av)} \times 0.5 \times I_D \times t \tag{2}$$

$$= 140 \text{ V} \times 0.5 \times 1 \text{ A} \times 0.5 \times 10^{-6}$$

$$= 0.035 \text{ (mJ)}$$

The E_{AV} thus calculated is compared with the graph shown in figure 15 to confirm that the E_{AV} is within the safe operating area of the avalanche breakdown voltage of the MOSFETs.

Thermal Design

The SLA7080M series incorporates a thermal protection function that shuts down all outputs when the Control IC temperature exceeds T_{TSD} . However, a comprehensive overtemperature protection function is not provided because the Control IC chip is separate from the MOSFET chips, the power elements which are the primary sources of heat. It would be unable to respond to sudden temperature changes in the MOSFETs because of delays in diffusion of the heat.

Therefore, sufficient thermal evaluation should be performed with the actual application, so that the junction temperature, T_J , does not exceed the absolute maximum rating (150°C). Experimentation is required because it is not practical to calculate a realistic power dissipation value, which involves variable parameters such as time constants and excitation modes during actual operation of motors, input frequencies and sequences, and so forth.

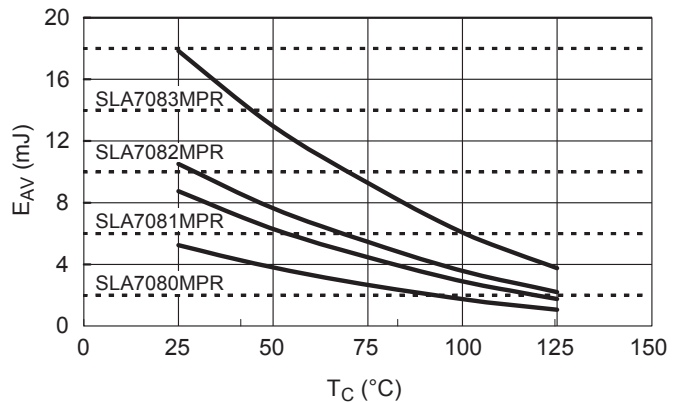

Figure 15. Avalanche breakdown voltages for repeated cycles

Given this situation, for initial design estimates, power dissipation should be calculated by approximation, using worst-case conditions, at 2-phase excitation:

$$P_D = I_O^2 \times (R_{DS(on)} + R_S) \times 2 \quad (6)$$

where:

P_D is the power dissipation of the SLA7080M,

I_O is the Output Current,

$R_{DS(on)}$ is the on-resistance of the MOSFETs, and

R_S is the Sense Resistor Resistance.

Based on the power dissipation of the product thus calculated, the junction temperature of the product is estimated by using the temperature rise curves of figure 16.

Unless the temperature exceeds 150°C under the worst conditions (the maximum values of ambient operating temperature), there will be no problem, but final judgment should be made by measuring the device temperature during the actual operation and then verifying power dissipation and junction temperature in accordance with figure 16.

When the device is used with a heatsink, the thermal resistance, $R_{\theta JA}$, of the device changes (as do the parameters used in calculating ΔT_{JA}). This value is calculated from the following

formula:

$$R_{\theta JA} \approx R_{\theta CA} + R_{\theta HS} \\ = (R_{\theta JA} - R_{\theta CA}) + R_{\theta HS} \quad (7)$$

where $R_{\theta HS}$ is the thermal resistance of the heatsink.

To estimate the junction temperature rise, ΔT_J , from the device temperature measured in the actual operating application, ΔT_{CA} , the following procedure should be followed:

1. The temperature rise of the product, ΔT_{CA} , is measured on pin 12, where it enters the case.
2. From the temperature rise thus obtained, the power dissipation, P_D , and the junction temperature, T_J , are estimated using figure 16.
3. Calculate the relationship between ΔT_{CA} and the junction temperature rise, ΔT_J , using the following formula:

$$\Delta T_J \approx \Delta T_{JC} + P_D \times R_{\theta JC} \quad (8)$$

Note that this thermal design information is provided for preliminary design estimations only. Users should verify the heat generation of the product in the actual operation, by measuring the case temperature, T_C , and comparing it to the Recommended Operating Conditions table values.

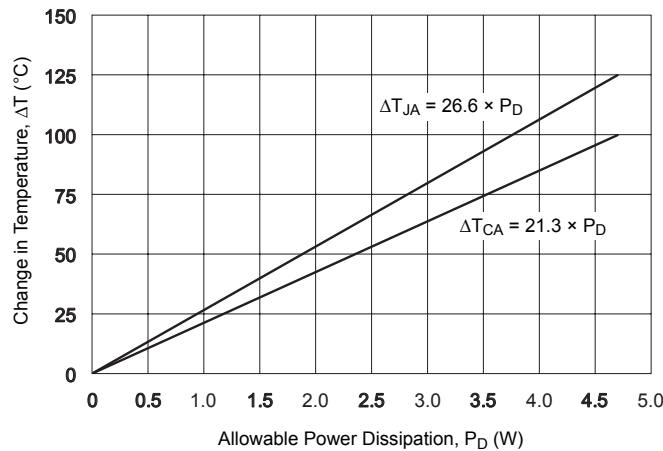
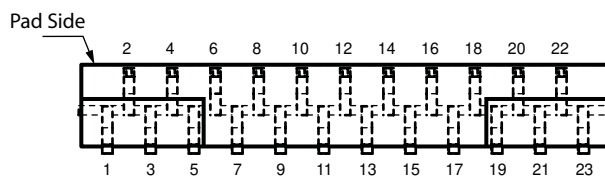

Figure 16. Power dissipation estimate for junction-to-ambient and case-to-ambient temperature change

Pin-out Diagram**Terminal List Table**

Number	Name	Function
1	OUTA	Output (phase A)
2		
3		
4		
5	SENSEA	Current sense (phase A)
6	B_SEL	Blanking time switching input
7	INA	Switching input (phase A)
8	$\overline{\text{INA}}$	
9	INB	Switching input (phase B)
10	$\overline{\text{INB}}$	
11	VBB	Main power supply (motor supply)
12	GND	Device ground terminal
13	REF/SLEEP	Control current/sleep enable input
14	VDD	Logic supply
15	GND1	Ground 1 terminal
16	GND2	Ground 2 terminal
17	SYNC	PWM synchronous/non-synchronous switching
18	FLAG	Output of protection circuit monitor
19	SENSEB	Current sense (phase B)
20	$\overline{\text{OUTB}}$	Output (phase B)
21		
22	OUTB	
23		

Package Outline Drawing

Dual rows, 23 alternating pins; vertical case mounting; pin #1 opposite pad side

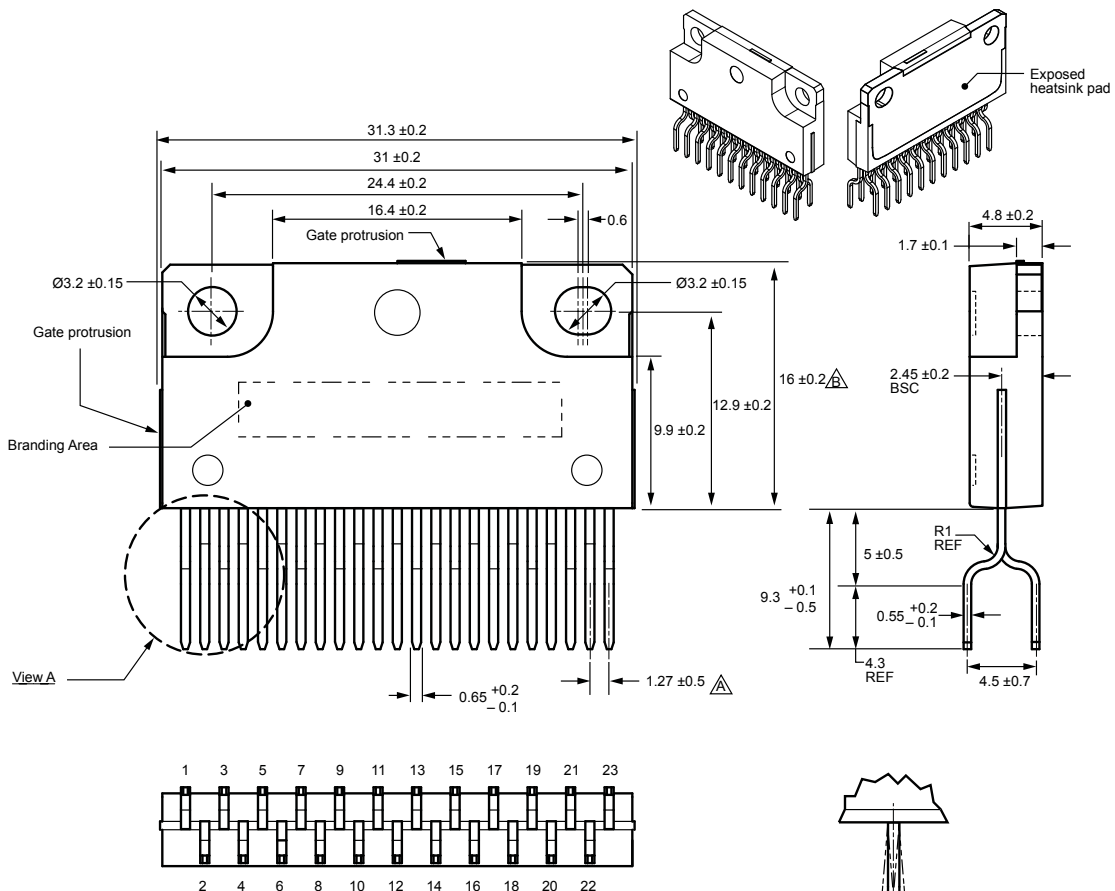

△ Measured at pin tips
 ▽ To case top

Terminal core material: Cu
 Terminal plating: Ni, with Pb-free solder coating
 Recommended attachment: Solder dip (Sn-Ag-Cu)

Dimensions in millimeters

Branding codes (exact appearance at manufacturer discretion):
 1st line, type: SLA708xMR
 2nd line, protection: P
 3rd line, lot: YMDD
 Where: Y is the last digit of the year of manufacture
 M is the month (1 to 9, O, N, D)
 DD is the date



Leadframe plating Pb-free. Device composition complies with the RoHS directive.

Because reliability can be affected adversely by improper storage environments and handling methods, please observe the following cautions.

Cautions for Storage

- Ensure that storage conditions comply with the standard temperature (5°C to 35°C) and the standard relative humidity (around 40 to 75%); avoid storage locations that experience extreme changes in temperature or humidity.
- Avoid locations where dust or harmful gases are present and avoid direct sunlight.
- Reinspect for rust on leads and solderability of products that have been stored for a long time.

Cautions for Testing and Handling

When tests are carried out during inspection testing and other standard test periods, protect the products from power surges from the testing device, shorts between adjacent products, and shorts to the heatsink.

Remarks About Using Silicone Grease with a Heatsink

- When silicone grease is used in mounting this product to a heatsink, it shall be applied evenly and thinly. If more silicone grease than required is applied, it may produce stress.
- Volatile-type silicone greases may permeate the product and produce cracks after long periods of time, resulting in reduced heat radiation effect, and possibly shortening the lifetime of the product.
- Our recommended silicone greases for heat radiation purposes, which will not cause any adverse effect on the product life, are indicated below:

Type	Suppliers
G746	Shin-Etsu Chemical Co., Ltd.
YG6260	Momentive Performance Materials Inc.
SC102	Dow Corning Toray Co., Ltd.

Heatsink Mounting Method

Torque When Tightening Mounting Screws. The recommended tightening torque for this product package type is: 58.8 to 78.4 N•cm (6.0 to 8.0 kgf•cm).

Soldering

- When soldering the products, please be sure to minimize the working time, within the following limits:
260±5°C 10 s
380±5°C 5 s
- Soldering iron should be at a distance of at least 1.5 mm from the body of the products

Electrostatic Discharge

- When handling the products, operator must be grounded. Grounded wrist straps worn should have at least 1 MΩ of resistance to ground to prevent shock hazard.
- Workbenches where the products are handled should be grounded and be provided with conductive table and floor mats.
- When using measuring equipment such as a curve tracer, the equipment should be grounded.
- When soldering the products, the head of soldering irons or the solder bath must be grounded in order to prevent leak voltages generated by them from being applied to the products.
- The products should always be stored and transported in our shipping containers or conductive containers, or be wrapped in aluminum foil.

-
- The contents in this document are subject to changes, for improvement and other purposes, without notice. Make sure that this is the latest revision of the document before use.
 - Application and operation examples described in this document are quoted for the sole purpose of reference for the use of the products herein and Sanken can assume no responsibility for any infringement of industrial property rights, intellectual property rights or any other rights of Sanken or any third party which may result from its use.
 - Although Sanken undertakes to enhance the quality and reliability of its products, the occurrence of failure and defect of semiconductor products at a certain rate is inevitable. Users of Sanken products are requested to take, at their own risk, preventative measures including safety design of the equipment or systems against any possible injury, death, fires or damages to the society due to device failure or malfunction.

- Sanken products listed in this document are designed and intended for the use as components in general purpose electronic equipment or apparatus (home appliances, office equipment, telecommunication equipment, measuring equipment, etc.).

When considering the use of Sanken products in the applications where higher reliability is required (transportation equipment and its control systems, traffic signal control systems or equipment, fire/crime alarm systems, various safety devices, etc.), and whenever long life expectancy is required even in general purpose electronic equipment or apparatus, please contact your nearest Sanken sales representative to discuss, prior to the use of the products herein.

The use of Sanken products without the written consent of Sanken in the applications where extremely high reliability is required (aerospace equipment, nuclear power control systems, life support systems, etc.) is strictly prohibited.

- In the case that you use Sanken products or design your products by using Sanken products, the reliability largely depends on the degree of derating to be made to the rated values. Derating may be interpreted as a case that an operation range is set by derating the load from each rated value or surge voltage or noise is considered for derating in order to assure or improve the reliability. In general, derating factors include electric stresses such as electric voltage, electric current, electric power etc., environmental stresses such as ambient temperature, humidity etc. and thermal stress caused due to self-heating of semiconductor products. For these stresses, instantaneous values, maximum values and minimum values must be taken into consideration.

In addition, it should be noted that since power devices or IC's including power devices have large self-heating value, the degree of derating of junction temperature affects the reliability significantly.

- When using the products specified herein by either (i) combining other products or materials therewith or (ii) physically, chemically or otherwise processing or treating the products, please duly consider all possible risks that may result from all such uses in advance and proceed therewith at your own responsibility.
- Anti radioactive ray design is not considered for the products listed herein.
- Sanken assumes no responsibility for any troubles, such as dropping products caused during transportation out of Sanken's distribution network.
- The contents in this document must not be transcribed or copied without Sanken's written consent.