

Board Level Cooling – Channel 5342



BOARD LEVEL COOLING – Channel 5342

Channel 5342 is a series of channel board level heat sinks designed to cool TO-220 and TO-220-single gauge devices. Representative image only.

ORDERING INFORMATION

Part Number	Device Type
534202B02853G	TO-220, TO-220-single gauge
534202B03453G	TO-220, TO-220-single gauge
534202B33453G	TO-220, TO-220-single gauge

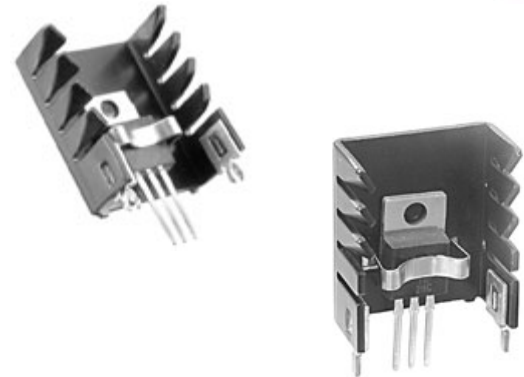

HEAT SINK DETAILS

Property	Details
Material	Aluminum
Finishing	Black Anodize
Device Attachment Options	Kool Clip (Included)
Thermal Interface Material	-

Property	Details
Heat Sink Width (mm)	25.40
Heat Sink Length (mm)	12.70
Heat Sink Height (mm)	29.97
Heat Sink Mounting Direction	Vertical

MECHANICAL & PERFORMANCE

Drawing dimensions are shown in mm, (in)

Part Number	"X" Dim	"Y" Dim	"Z" Dim
534202B02853G	11.18 (0.440)	8.00 (0.315)	2.39 (0.094)
534202B03453G	11.96 (0.471)	8.89 (0.350)	2.39 (0.094)
534202B33453G	11.84 (0.466)	8.89 (0.350)	2.39 (0.094)

Part Number: 534202B02853G

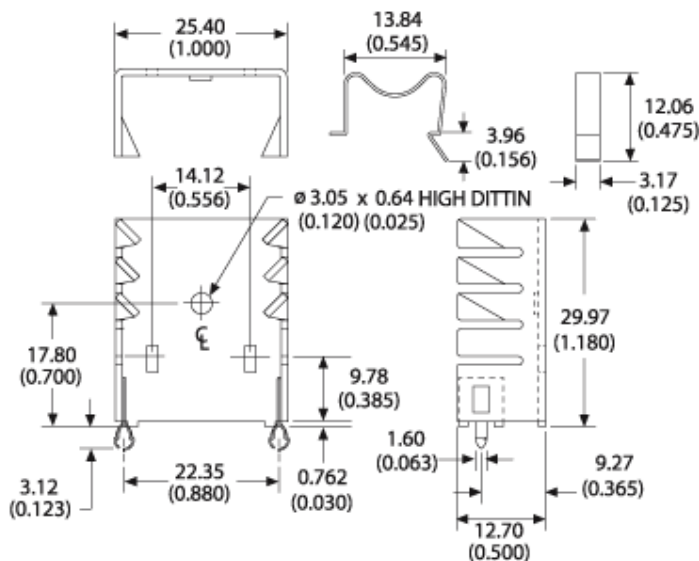

Mounting Details:

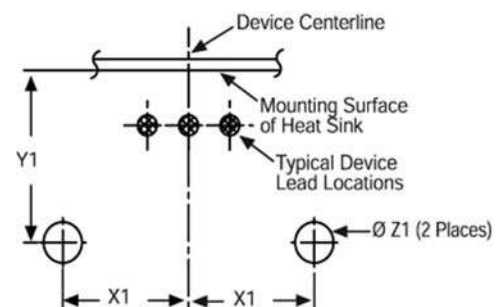

Board Level Cooling – Channel 5342

Part Number: 534202B03453G

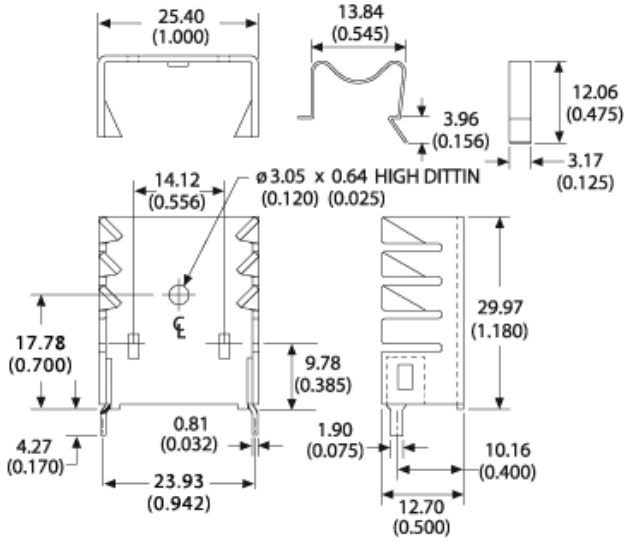

Mounting Details:

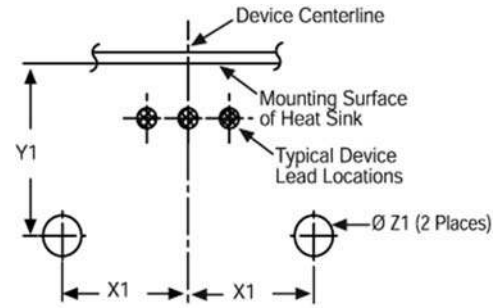

Part Number: 534202B33453G

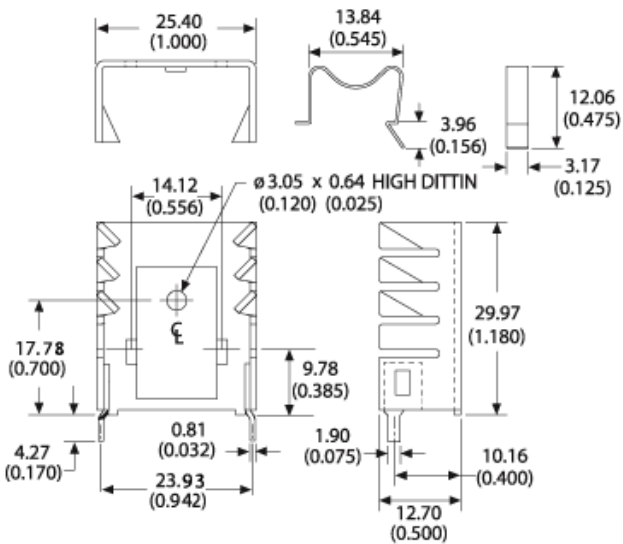

Mounting Details:

