



ON Semiconductor®

<http://onsemi.com>

# LV5213LP

## Bi-CMOS LSI 3ch LED Driver

### Overview

This LV5213LP is LED driver for cell phones. Each LED driver gets a constant current controlled. The brilliance control becomes possible by changing the current value that flows to LED by the serial bus control. LV5213LP can achieve various effects of the illumination of a full-color LED display.

### Functions

- Three color LED driver circuits.
- The LED current can be switched independently in 5-bit units (0 to 5mA).
- Independent on/off control of the three LED drivers (independent control of the 3 RGB colors).
- Each LED drive current level can be adjusted independently over the serial bus.
- Miniature package.
- Thermal shutdown circuit.

### Specifications

#### Absolute Maximum Ratings at Ta = 25°C

Parameter	Symbol	Conditions	Ratings	Unit
Supply voltage 1	V <sub>CC</sub> max		6.0	V
Supply voltage 2	V <sub>DD</sub> max		6.0	V
Allowable power dissipation	P <sub>d</sub> max	Mounted on the specified board *	5.5	W
Maximum input current	V <sub>INB</sub>		6.0	V
Maximum output current	I <sub>O</sub> max		12.0	mA
STBY pin voltage	V <sub>STBY</sub>		6.0	V
Operating temperature	T <sub>opr</sub>		-30 to +75	°C
Storage temperature	T <sub>stg</sub>		-40 to +125	°C

The specified board \*: 50mm × 40mm × 0.8mm glass epoxy (4-layer circuit board).

Stresses exceeding Maximum Ratings may damage the device. Maximum Ratings are stress ratings only. Functional operation above the Recommended Operating Conditions is not implied. Extended exposure to stresses above the Recommended Operating Conditions may affect device reliability.

# LV5213LP

## Recommended Operating Conditions at $T_a = 25^\circ\text{C}$

Parameter	Symbol	Conditions	Ratings	Unit
Supply voltage 1	$V_{CC}$		3.0 to 4.5	V
Supply voltage 2	$V_{DD}$		1.6 to 3.0	V

## Electrical Characteristics

### Operating Characteristics at $V_{CC} = 3.7\text{V}$ , $V_{DD} = 1.8\text{V}$ , $R_T = 82\Omega$ , $T_a = 25^\circ\text{C}$

Parameter	Symbol	Conditions	Ratings			Unit
			min	typ	max	
Overall Characteristics						
Current drain 1	$I_{CC1}$	STBY = L *1			5	$\mu\text{A}$
Current drain 2	$I_{CC2}$	STBY = H, RON = GON = BON = L *1 With the default serial data settings		0.6	2	mA
High-level input voltage 1	$V_{INH1}$	Serial data signals, each of the "ON" pins	$V_{DD} \times 0.8$			V
Low-level input voltage 1	$V_{INL1}$	Serial data signals, each of the "ON" pins	0		$V_{DD} \times 0.2$	V
High-level input voltage 2	$V_{INH2}$	STBY pin	$V_{DD} \times 0.8$			V
Low-level input voltage 2	$V_{INL2}$	STBY pin	0		$V_{DD} \times 0.2$	V
LED Driver Block						
Minimum output current 1	$I_{min1}$	When the serial data is 00000, $V_O = 0.5\text{V}$		0.54		mA
Maximum output current 1	$I_{max1}$	When the serial data is 11111, $V_O = 0.5\text{V}$		4.74		mA
Linearity error	LE	*2	-3		3	LSB
Differential linearity error	DLE	*3	-2		2	LSB
Maximum output current	$\Delta IL$	At the maximum current setting, $V_O = 2$ to $0.15\text{V}$	-10			%
Leakage current	$I_{leak}$	Drivers: off, $V_O = 5\text{V}$			1	$\mu\text{A}$

- \*1. The sum of the  $V_{CC}$  and  $V_{DD}$  current drain values.
- \*2. Linearity error: The difference between the actual and ideal current values.
- \*3. Differential linearity error: The difference between the actual and ideal amounts when one low-order bit value is added.

## Package Dimensions

unit : mm

3318

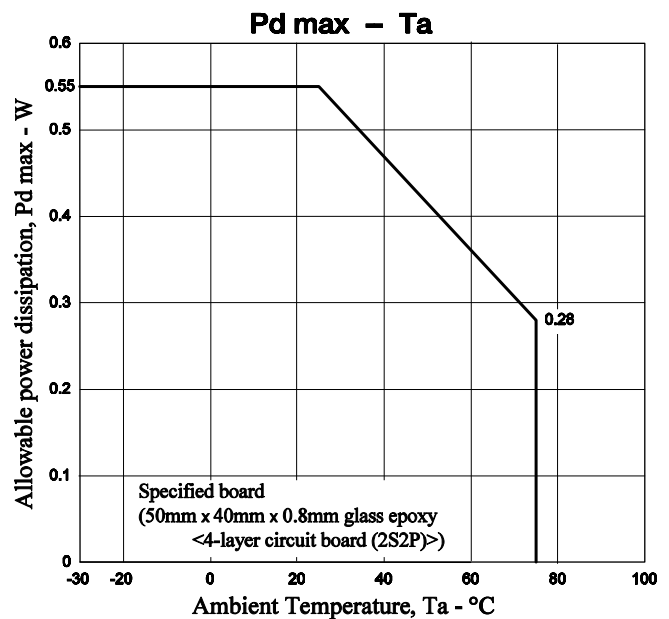
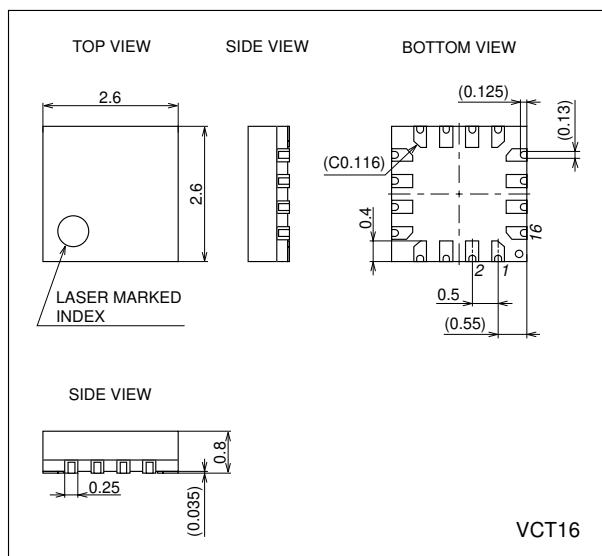

# LV5213LP

## Block Diagram

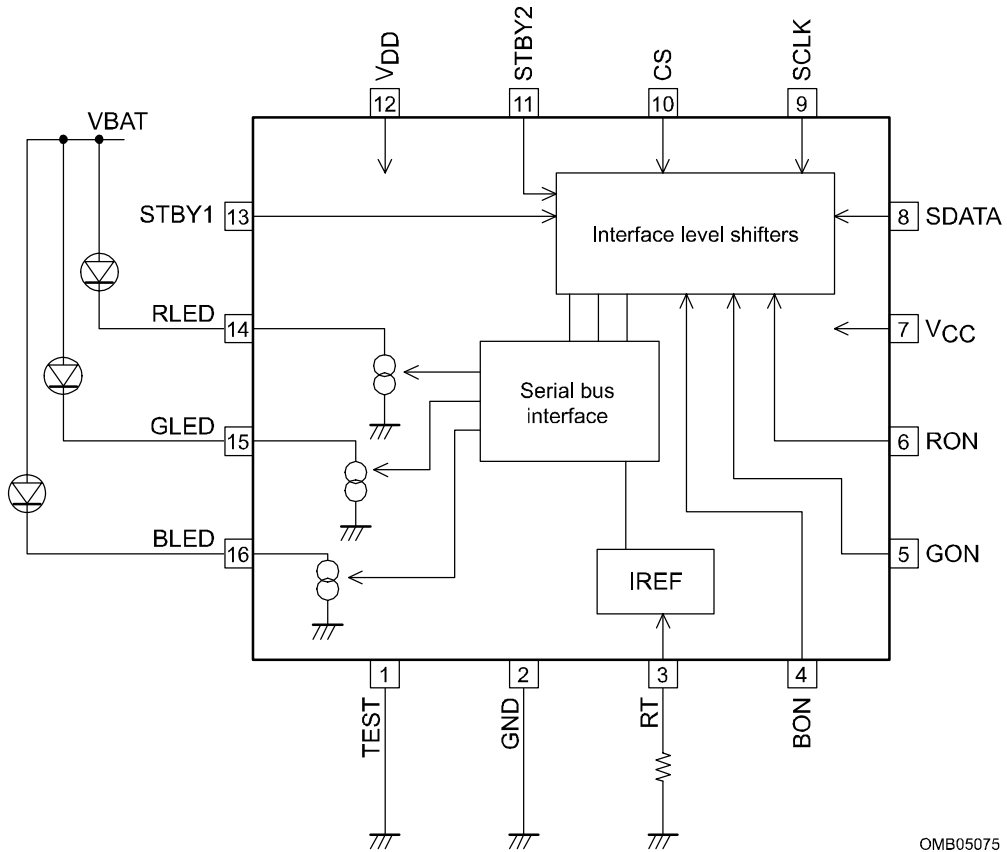

OMB05075

Note 1: The TEST pin must be tied to ground.

## Serial Data Map

Register address								Data							
A7	A6	A5	A4	A3	A2	A1	A0	D7	D6	D5	D4	D3	D2	D1	D0
0	0	0	0	0	0	0	1	×	×	RSW	R[4:0]				
0	0	0	0	0	0	1	0	0	0	0	0	0	0	0	0
0	0	0	0	0	0	0	1	×	×	GSW	G[4:0]				
0	0	0	0	0	0	0	1	0	0	0	0	0	0	0	0
0	0	0	0	0	0	1	1	×	×	BSW	B[4:0]				
0	0	0	0	0	0	1	1	0	0	0	0	0	0	0	0

Upper row: Register name, Lower row: default value

# LV5213LP

## Serial Data Mode Settings

### R mode

Register address								Data							
0	0	0	0	0	0	0	1	0	0	D5	D4	D3	D2	D1	D0

RLED output setting

D5	RSW
0	OFF (Default)
1	ON

RLED current setting

D4	D3	D2	D1	D0	Current [mA]
0	0	0	0	0	0.544 (Default)
0	0	0	0	1	0.679
0	0	0	1	0	0.815
0	0	0	1	1	0.950
0	0	1	0	0	1.085
0	0	1	0	1	1.220
0	0	1	1	0	1.356
0	0	1	1	1	1.491
0	1	0	0	0	1.626
0	1	0	0	1	1.761
0	1	0	1	0	1.897
0	1	0	1	1	2.032
0	1	1	0	0	2.167
0	1	1	0	1	2.302
0	1	1	1	0	2.438
0	1	1	1	1	2.573
1	0	0	0	0	2.708
1	0	0	0	1	2.843
1	0	0	1	0	2.979
1	0	0	1	1	3.114
1	0	1	0	0	3.249
1	0	1	0	1	3.384
1	0	1	1	0	3.520
1	0	1	1	1	3.655
1	1	0	0	0	3.790
1	1	0	0	1	3.925
1	1	0	1	0	4.061
1	1	0	1	1	4.196
1	1	1	0	0	4.331
1	1	1	0	1	4.466
1	1	1	1	0	4.602
1	1	1	1	1	4.737

# LV5213LP

## G mode

Register address								Data							
0	0	0	0	0	0	1	0	0	0	D5	D4	D3	D2	D1	D0

GLEED output setting

D5	GSW
0	OFF (Default)
1	ON

GLEED current setting

D4	D3	D2	D1	D0	Current [mA]
0	0	0	0	0	0.544 (Default)
0	0	0	0	1	0.679
0	0	0	1	0	0.815
0	0	0	1	1	0.950
0	0	1	0	0	1.085
0	0	1	0	1	1.220
0	0	1	1	0	1.356
0	0	1	1	1	1.491
0	1	0	0	0	1.626
0	1	0	0	1	1.761
0	1	0	1	0	1.897
0	1	0	1	1	2.032
0	1	1	0	0	2.167
0	1	1	0	1	2.302
0	1	1	1	0	2.438
0	1	1	1	1	2.573
1	0	0	0	0	2.708
1	0	0	0	1	2.843
1	0	0	1	0	2.979
1	0	0	1	1	3.114
1	0	1	0	0	3.249
1	0	1	0	1	3.384
1	0	1	1	0	3.520
1	0	1	1	1	3.655
1	1	0	0	0	3.790
1	1	0	0	1	3.925
1	1	0	1	0	4.061
1	1	0	1	1	4.196
1	1	1	0	0	4.331
1	1	1	0	1	4.466
1	1	1	1	0	4.602
1	1	1	1	1	4.737

# LV5213LP

## B mode

Register address								Data							
0	0	0	0	0	0	1	1	0	0	D5	D4	D3	D2	D1	D0

BLED output setting

D5	BSW
0	OFF (Default)
1	ON

BLED current setting

D4	D3	D2	D1	D0	Current [mA]
0	0	0	0	0	0.544 (Default)
0	0	0	0	1	0.679
0	0	0	1	0	0.815
0	0	0	1	1	0.950
0	0	1	0	0	1.085
0	0	1	0	1	1.220
0	0	1	1	0	1.356
0	0	1	1	1	1.491
0	1	0	0	0	1.626
0	1	0	0	1	1.761
0	1	0	1	0	1.897
0	1	0	1	1	2.032
0	1	1	0	0	2.167
0	1	1	0	1	2.302
0	1	1	1	0	2.438
0	1	1	1	1	2.573
1	0	0	0	0	2.708
1	0	0	0	1	2.843
1	0	0	1	0	2.979
1	0	0	1	1	3.114
1	0	1	0	0	3.249
1	0	1	0	1	3.384
1	0	1	1	0	3.520
1	0	1	1	1	3.655
1	1	0	0	0	3.790
1	1	0	0	1	3.925
1	1	0	1	0	4.061
1	1	0	1	1	4.196
1	1	1	0	0	4.331
1	1	1	0	1	4.466
1	1	1	1	0	4.602
1	1	1	1	1	4.737

# LV5213LP

## Pin Functions

Pin No.	Pin	Function
1	TEST	Test signal input. This pin must be connected to ground.
2	GND	Ground
3	RT	Reference current setting resistor connection
4	BON	External blue LED control input
5	GON	External green LED control input
6	RON	External red LED control input
7	V <sub>CC</sub>	Circuit system power supply
8	SDATA	Serial data signal input
9	SCLK	Serial clock signal input
10	CS	Chip select
11	STBY2	Standby mode 2 control
12	V <sub>DD</sub>	Control system (RON, GON, BON, SDATA, SCLK, and CS pins) power supply
13	STBY1	Standby mode 1 control
14	RLED	Red LED driver output
15	GLED	Green LED driver output
16	BLED	Blue LED driver output

## Serial Data Transfer Timing Conditions

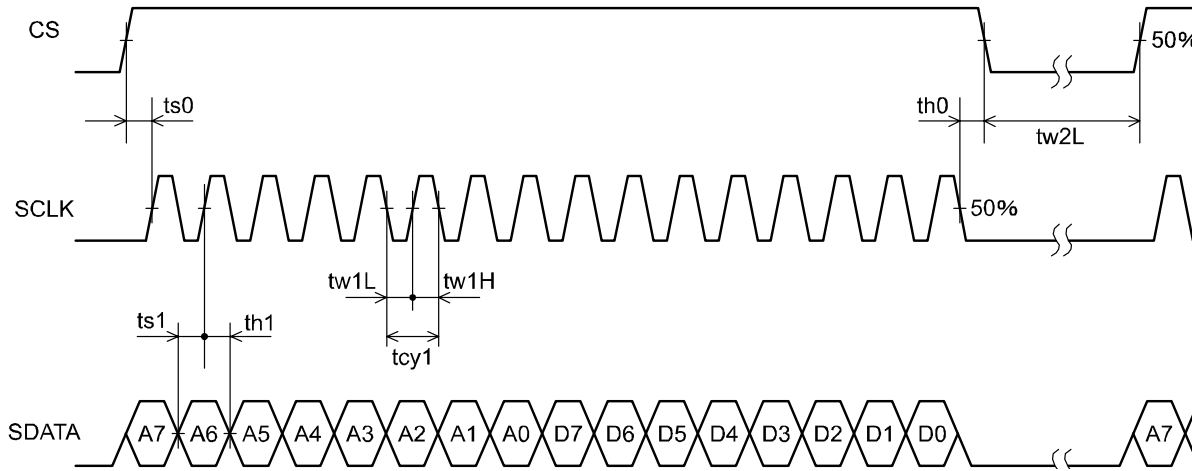

Parameter	Symbol	Conditions	min	typ	max	unit
Cycle time	tcy1	SCLK clock period	330			nS
Data setup time	ts0	The CS setup time from the SCLK rising edge	150			nS
	ts1	The SDATA setup time from the SCLK rising edge	100			nS
Data hold time	th0	The CS hold time from the SCLK falling edge	300			nS
	th1	The SDATA hold time from the SCLK rising edge	100			nS
Pulse width	tw1L	SCLK low period pulse width	150			nS
	tw1H	SCLK high period pulse width	150			nS
	tw2L	CS low period pulse width	1.0			μS

Data length: 16bits  
 Clock frequency: Up to 2MHz

After 16 clock cycles have been input with CS at the high level, SDATA is acquired on the fall of CS.

Note: SDATA will not be acquired if 15 or fewer clock cycles were input during the CS high-level period. If 17 or more clock cycles are input, the SDATA for the first 16 cycles are acquired and the SDATA following those 16 cycles is ignored.

### Power Supply Application

1. Either bring up VCC and VDD at the same time, or bring up VCC first then VDD.
2. Then, set the serial data. (After the serial data has been set, a period of about 2μs is required as the startup time for the IC internal circuits.)
3. Finally, clear the STBY pin states.



# LV5213LP

## Pin Descriptions and Equivalent Circuits

Pin No.	Symbol	Equivalent circuit	Description
4 5 6	BON GON RON	<p style="text-align: right;">OMP05194</p>	Control inputs for the three external colored LEDs When an RSW, GSW, or BSW bit in the serial data is set to 1, the corresponding LED will be on when the voltage applied to the corresponding pin is high, and off when the voltage applied is low.
8 9 10	SDATA SCLK CS	<p style="text-align: right;">OMP05195</p>	Serial data system inputs
3	RT	<p style="text-align: right;">OMP05196</p>	Reference current setting resistor connection A reference current is created by connecting an external resistor between this pin and ground. The pin voltage is roughly 1.2V. The LED driver current can be changed by changing this current value.
14 15 16	RLED GLED BLED	<p style="text-align: right;">OMP05197</p>	Driver outputs for the three color LEDs Feedback is applied to control the current flowing in the output transistors to be the set value. Each of the driver output current levels can be set independently with the serial data.

Continued on next page.

# LV5213LP

Continued from preceding page.

Pin No.	Symbol	Equivalent circuit	Description
1	TEST	<p style="text-align: right;">OMP05198</p>	<p>Test signal input</p> <p>This pin must be tied to ground.</p>
11 13	STBY2 STBY1	<p style="text-align: right;">OMP05199</p>	<p>Standby mode pins</p> <p>The LV5213LP goes to standby mode when both the STBY1 and STBY2 pins are at the low level.</p>
7	V <sub>CC</sub>		Circuit system power supply
12	V <sub>DD</sub>		Control system (serial data inputs and "ON" inputs) power supply
3	GND		Ground

ON Semiconductor and the ON logo are registered trademarks of Semiconductor Components Industries, LLC (SCILLC). SCILLC owns the rights to a number of patents, trademarks, copyrights, trade secrets, and other intellectual property. A listing of SCILLC's product/patent coverage may be accessed at [www.onsemi.com/site/pdf/Patent-Marking.pdf](http://www.onsemi.com/site/pdf/Patent-Marking.pdf). SCILLC reserves the right to make changes without further notice to any products herein. SCILLC makes no warranty, representation or guarantee regarding the suitability of its products for any particular purpose, nor does SCILLC assume any liability arising out of the application or use of any product or circuit, and specifically disclaims any and all liability, including without limitation special, consequential or incidental damages. "Typical" parameters which may be provided in SCILLC data sheets and/or specifications can and do vary in different applications and actual performance may vary over time. All operating parameters, including "Typicals" must be validated for each customer application by customer's technical experts. SCILLC does not convey any license under its patent rights nor the rights of others. SCILLC products are not designed, intended, or authorized for use as components in systems intended for surgical implant into the body, or other applications intended to support or sustain life, or for any other application in which the failure of the SCILLC product could create a situation where personal injury or death may occur. Should Buyer purchase or use SCILLC products for any such unintended or unauthorized application, Buyer shall indemnify and hold SCILLC and its officers, employees, subsidiaries, affiliates, and distributors harmless against all claims, costs, damages, and expenses, and reasonable attorney fees arising out of, directly or indirectly, any claim of personal injury or death associated with such unintended or unauthorized use, even if such claim alleges that SCILLC was negligent regarding the design or manufacture of the part. SCILLC is an Equal Opportunity/Affirmative Action Employer. This literature is subject to all applicable copyright laws and is not for resale in any manner.