

UM10699

User manual for SPI-bus RTC demoboard OM11059

Rev. 2 — 12 February 2015

User manual

Document information

Info	Content
Keywords	PCF85063BTL, OM11059, demoboard, how to get started, SPI-bus, RTC, Real-Time Clock, tuning
Abstract	User manual for the RTC SPI-bus demoboard OM11059 which contains PCF85063BTL



Revision history

Rev	Date	Description
v.2	20150212	revised version
v.1	20130404	new user manual, first revision

Contact information

For more information, please visit: <http://www.nxp.com>

For sales office addresses, please send an email to: salesaddresses@nxp.com

1. Introduction

The PCF85063x are a family of CMOS Real-Time Clocks (RTC) and calendar optimized for low power consumption. Different features sets are available.

The OM11059 is the ideal evaluation/demo board to use in the design phase of any project, just power and SPI-bus must be hooked up.

A separate demoboard and a user manual are available for the I²C-bus RTCs PCF85063AT:OM13515 and UM10788.

2. Key features

The RTC PCF85063BTL with SPI-bus is mounted together with a quartz crystal and the blocking capacitor, buffering the supply voltage.

2.1 PCF85063BTL

The RTC PCF85063BTL is a Real-Time Clock with very small form factor, counting seconds, minutes, hours, days, weekdays, months, and years.

Electronic oscillator tuning

RAM: 1 Byte

Package: HXSON10 package: 2.6 x 2.6 x 0.5 mm

Alarm control

Timer

Interrupt: every 30 s or 60 s, alarm, timer

Interface: SPI-bus, up to 8 MHz

Clock out: enabled by pin or by software

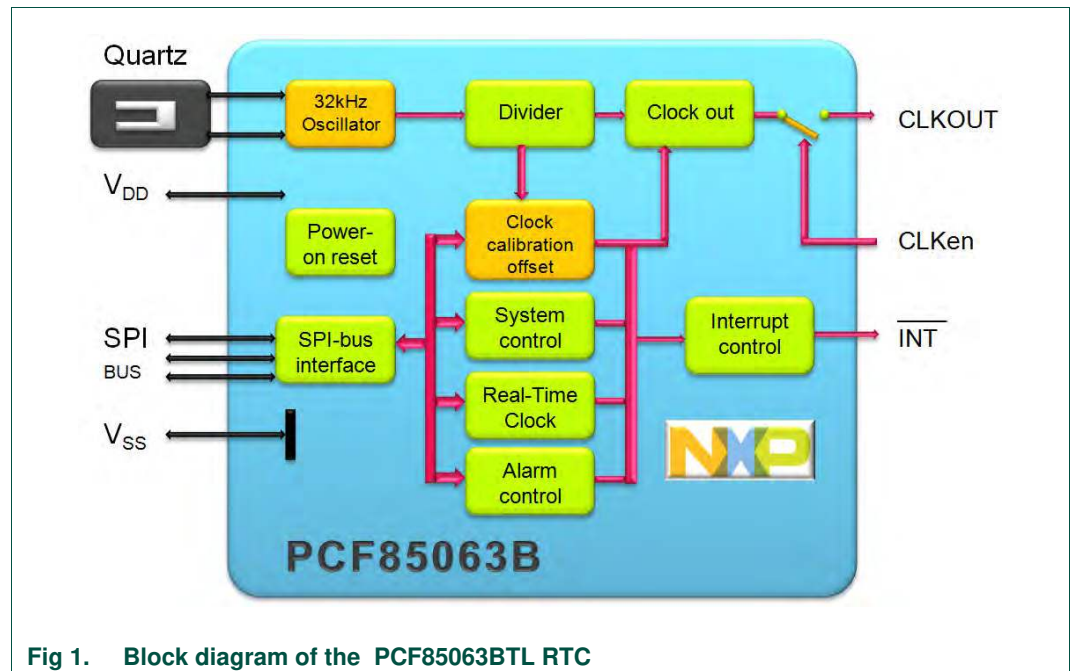

Fig 1. Block diagram of the PCF85063BTL RTC

3. Hardware set-up

3.1 General requirements for the RTC PCF85063BTL

The RTC circuit just requires one external part: a tuning fork quartz as resonator. The oscillation capacitors are integrated and therefore there is no need for external capacitors. The quartz crystal must be placed close to the RTC circuit, avoiding long lines which may pick up noise. Avoid any tracks with high frequency signals (fast edges) close to the RTC, quartz, or quartz interconnect.

The interface uses a three-line standard SPI protocol: chip enable, serial clock, serial data I/O operating up to 8 MHz.

Supply voltage: The RTC is specified from 1.8 V to 5.5 V. The RTC, excluding the SPI-bus interface, is however operating down to a lower voltage. It is recommended to have a decoupling capacitor on the VDD-VSS rails close by.

Due to the low power consumption of below 1 μ W, no precautions for heat dissipations are required.

CLKOUT can be used to measure the frequency or be used as reference for frequency generation with a PLL.

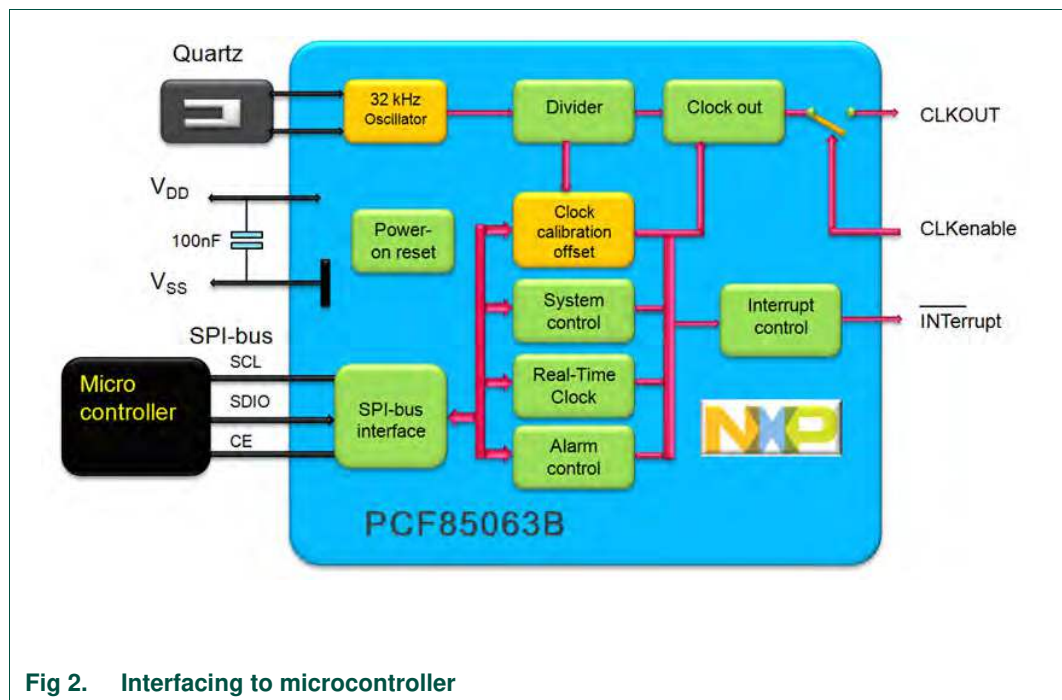

Fig 2. Interfacing to microcontroller

3.2 Demo board OM11059

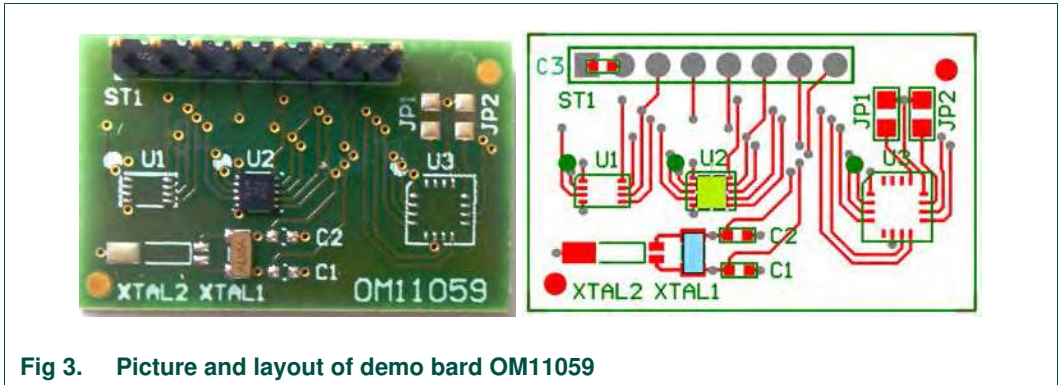

Fig 3. Picture and layout of demo board OM11059

The OM11059 allows to easily demonstrate operation of the PCF85063BTL with SPI-bus interface. No need to solder the tiny package to a breadboard 100 mil connector for straight forward connections.

There are quartzes on the market with different load capacitance C_L . 12.5 pF is most common, 7 pF offers however lower power consumption. By default a quartz with 7 pF is mounted. Additional landing pads are available on the board to take a quartz in a tubular package.

Straight forward interfacing:

- Connect supply voltage (e.g. 3.3 V): VSS to pin 1, VDD to pin 2
- Connect SPI-bus: CE to pin 4, SCL to pin 3, SDI/O to pin 7
- Communicate to the RTC

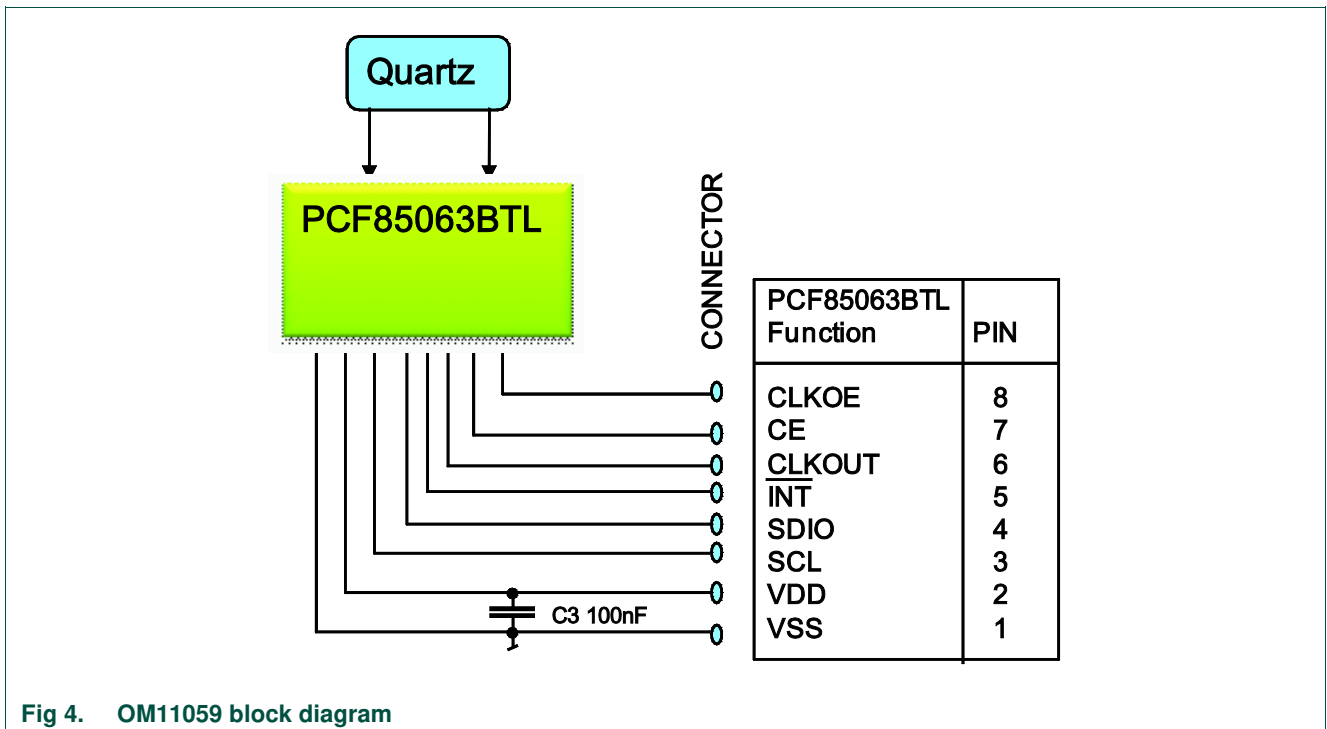
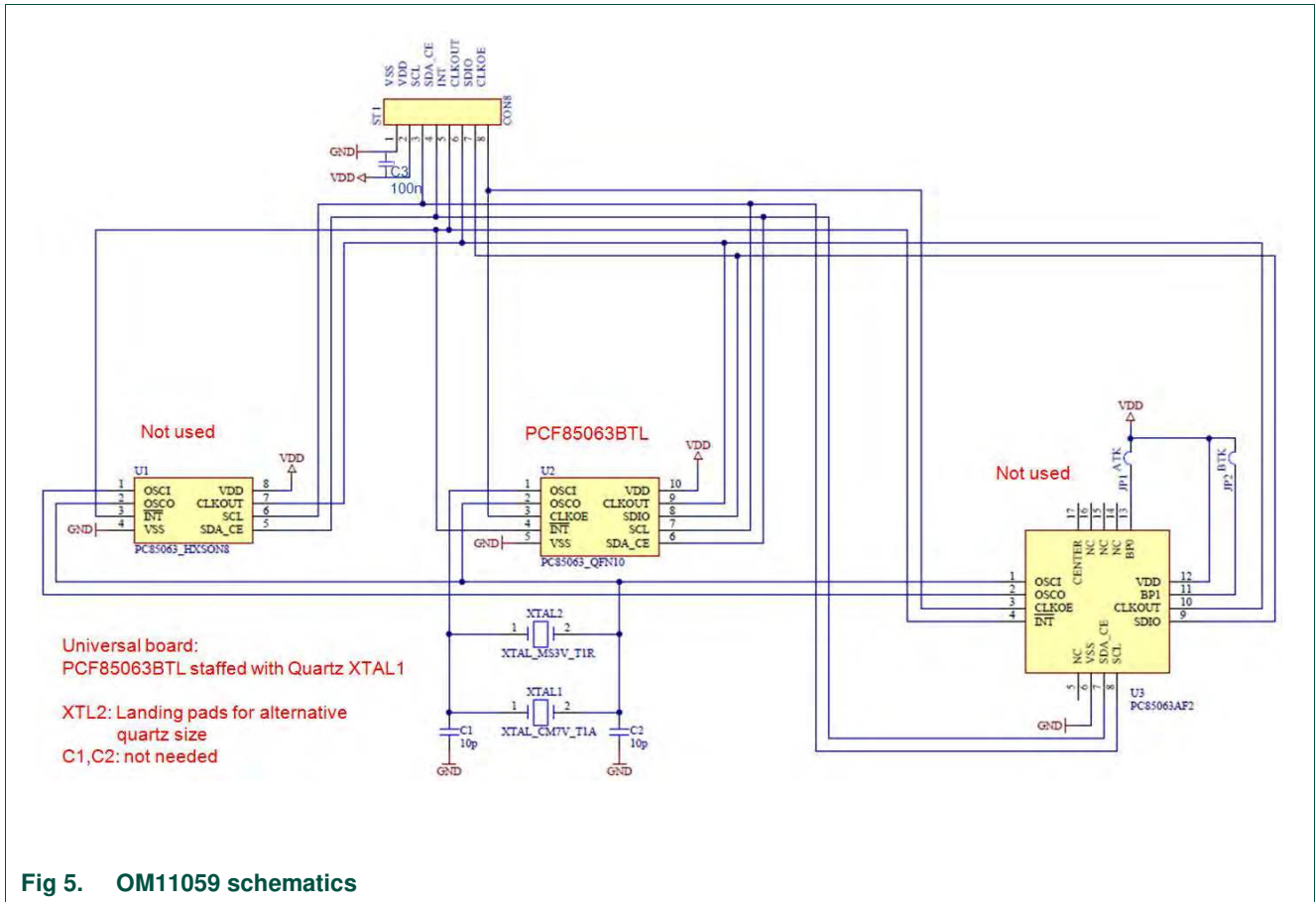

Fig 4. OM11059 block diagram



4. Software set-up

4.1 Functionality

The RTC PCF85063BTL is controlled via standard SPI-bus interface. Common SPI protocol applies.

Theoretically there is no lower speed limit, however a read or write access to the RTC must be finalized within one second after initiating it, otherwise time counter increments could be lost. During access, the time registers of the RTC are frozen and after the read or write sequence is completed, a seconds increment is executed if required.

The clock tracks the actual time from seconds to year. It must be initially set to the correct time of the actual time zone. The days per month and leap year are corrected automatically. Leap years are assumed whenever the year is dividable by 4.

The RTC can be programmed to generate an interrupt every 30 seconds or every 60 seconds.

At address byte 03h is a general purpose RAM byte to store temporary information.

4.2 System testing

There is a fast mode facility to test the functionality of the RTC; it can be activated by setting the EXT_TEST bit in the Control_1 word.

The RTC PCF85063BTL has a frequency tuning facility; its operation is explained in section 5.

The RTC can stay switched on all the time. There is no need to restart or reset the clock.

4.3 Software instructions for setting the clock

4.3.1 Setting the time

Setting the clock to 3.45 pm February 14, 2015,

- CE chip enable
- Register address 0000 0000 address pointer to status word 0
- Status word 0 0000 0011 set 12 hour mode and select option for 12.5 pF quartz
- 0000 0010 set 12 hour mode and select option for 7 pF quartz
- CE chip disable
- CE chip enable
- Register address 0000 0100 address pointer to seconds register
- Seconds 0000 0000 0 Seconds (clock integrity ok → MSB OS = 0)
- Minutes 0100 0101 45 min
- Hours 0010 0011 PM, 3 (clock integrity ok → OS = 0)
- Days 0001 0100 14th day of month
- Weekdays 0000 0110 Saturday (6th day of the week)
- Month 0000 0010 February
- Year 0001 0101 (20)15
- CE chip disable

4.3.2 Reading the clock

- Reading the clock (2 minutes after writing)
- CE chip enable
- Register address 0000 0100 address pointer to seconds (R/W bit = 1)
- Read register 4, seconds e.g. 56 Seconds, (clock integrity ok → OS = 0)
- Minutes e.g. 46 (Minutes)
- Hours e.g. 03 (PM 03h)
- Days e.g. 14 (14th)
- Weekdays e.g. 06 (Saturday)
- Month e.g. 02 (February)
- Year e.g. 15 (20)15
- CE chip disable

5. RTC tuning

5.1 Frequency tuning

The 32 kHz quartzes are typically sold with a tolerance at room temperature of either ± 10 ppm or ± 20 ppm. 11.5 ppm corresponds to 1 s/day.

The quartzes require a characteristic load capacity of either 7 pF or 12.5 pF. Oscillators utilizing 7 pF quartzes feature slightly lower power consumption, where the quartzes of 12.5 pF have largest production quantities. The tracks between quartz and RTC represent also some parasitic capacitances and must be kept short.

The PCF85063 has a tuning facility where above tolerances can be compensated. Tuning procedure:

- Measure the 32xxx Hz (f) signal at the CLKOUT pin.
- The offset is calculated in ppm as
$$\Delta f_{[\text{ppm}]} = 10^6 \times (f - 32768) / 32768$$
- Consult the offset table in the data sheet. Take the correction value and write it into the register 02h.
- The correction is done by means of inhibition or addition: the oscillator runs at constant speed, then every 2 hours (mode 0) 1 second is corrected to by making it shorter or longer. This is not easily visible at the CLKOUT.
- Corrections can also be applied every 4 minutes by using mode 1. This mode will consume slightly more power.

The 32 kHz quartzes are of the type tuning fork and feature a parabolic frequency response over temperature. When the application is dominantly used over a limited temperature range, it is often helpful to tune the frequency to be slightly higher at the turn-over point. The error around 25 °C (clock goes too fast) is then compensated during the time when temperature is lower or higher. For example, for operation between 5 °C and 45 °C, tune the clock 8 ppm faster than the value for 25 °C would be. (Fig 6.)

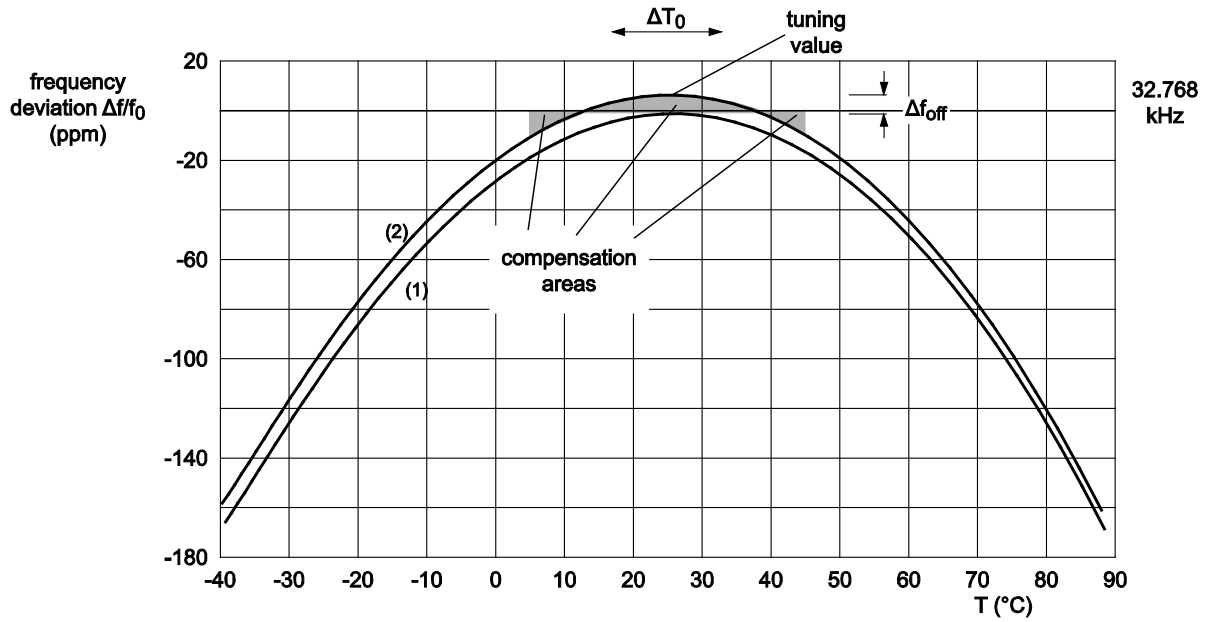

- (1) Characteristic if tuned to 32.768 kHz at 25 °C.
- (2) Characteristic if tuned with the positive offset Δf_{off} .

Fig 6. Temperature averaged over application range 5 °C to 45 °C

6. Legal information

6.1 Definitions

Draft — The document is a draft version only. The content is still under internal review and subject to formal approval, which may result in modifications or additions. NXP Semiconductors does not give any representations or warranties as to the accuracy or completeness of information included herein and shall have no liability for the consequences of use of such information.

6.2 Disclaimers

Limited warranty and liability — Information in this document is believed to be accurate and reliable. However, NXP Semiconductors does not give any representations or warranties, expressed or implied, as to the accuracy or completeness of such information and shall have no liability for the consequences of use of such information.

In no event shall NXP Semiconductors be liable for any indirect, incidental, punitive, special or consequential damages (including - without limitation - lost profits, lost savings, business interruption, costs related to the removal or replacement of any products or rework charges) whether or not such damages are based on tort (including negligence), warranty, breach of contract or any other legal theory.

Notwithstanding any damages that customer might incur for any reason whatsoever, NXP Semiconductors' aggregate and cumulative liability towards customer for the products described herein shall be limited in accordance with the Terms and conditions of commercial sale of NXP Semiconductors.

Right to make changes — NXP Semiconductors reserves the right to make changes to information published in this document, including without limitation specifications and product descriptions, at any time and without notice. This document supersedes and replaces all information supplied prior to the publication hereof.

Suitability for use — NXP Semiconductors products are not designed, authorized or warranted to be suitable for use in life support, life-critical or safety-critical systems or equipment, nor in applications where failure or malfunction of an NXP Semiconductors product can reasonably be expected to result in personal injury, death or severe property or environmental damage. NXP Semiconductors accepts no liability for inclusion and/or use of NXP Semiconductors products in such equipment or applications and therefore such inclusion and/or use is at the customer's own risk.

Applications — Applications that are described herein for any of these products are for illustrative purposes only. NXP Semiconductors makes no representation or warranty that such applications will be suitable for the specified use without further testing or modification.

Customers are responsible for the design and operation of their applications and products using NXP Semiconductors products, and NXP Semiconductors accepts no liability for any assistance with applications or customer product design. It is customer's sole responsibility to determine whether the NXP Semiconductors product is suitable and fit for the

customer's applications and products planned, as well as for the planned application and use of customer's third party customer(s). Customers should provide appropriate design and operating safeguards to minimize the risks associated with their applications and products.

NXP Semiconductors does not accept any liability related to any default, damage, costs or problem which is based on any weakness or default in the customer's applications or products, or the application or use by customer's third party customer(s). Customer is responsible for doing all necessary testing for the customer's applications and products using NXP Semiconductors products in order to avoid a default of the applications and the products or of the application or use by customer's third party customer(s). NXP does not accept any liability in this respect.

Export control — This document as well as the item(s) described herein may be subject to export control regulations. Export might require a prior authorization from competent authorities.

Evaluation products — This product is provided on an "as is" and "with all faults" basis for evaluation purposes only. NXP Semiconductors, its affiliates and their suppliers expressly disclaim all warranties, whether express, implied or statutory, including but not limited to the implied warranties of non-infringement, merchantability and fitness for a particular purpose. The entire risk as to the quality, or arising out of the use or performance, of this product remains with customer.

In no event shall NXP Semiconductors, its affiliates or their suppliers be liable to customer for any special, indirect, consequential, punitive or incidental damages (including without limitation damages for loss of business, business interruption, loss of use, loss of data or information, and the like) arising out of the use of or inability to use the product, whether or not based on tort (including negligence), strict liability, breach of contract, breach of warranty or any other theory, even if advised of the possibility of such damages.

Notwithstanding any damages that customer might incur for any reason whatsoever (including without limitation, all damages referenced above and all direct or general damages), the entire liability of NXP Semiconductors, its affiliates and their suppliers and customer's exclusive remedy for all of the foregoing shall be limited to actual damages incurred by customer based on reasonable reliance up to the greater of the amount actually paid by customer for the product or five dollars (US\$5.00). The foregoing limitations, exclusions and disclaimers shall apply to the maximum extent permitted by applicable law, even if any remedy fails of its essential purpose.

Translations — A non-English (translated) version of a document is for reference only. The English version shall prevail in case of any discrepancy between the translated and English versions.

6.3 Trademarks

Notice: All referenced brands, product names, service names and trademarks are property of their respective owners.

7. List of figures

Fig 1.	Block diagram of the PCF85063BTL RTC	3
Fig 2.	Interfacing to microcontroller	4
Fig 3.	Picture and layout of demo board OM11059.....	5
Fig 4.	OM11059 block diagram	5
Fig 5.	OM11059 schematics	6
Fig 6.	Temperature averaged over application range 5 °C to 45 °C	9

8. Contents

1.	Introduction	3
2.	Key features	3
2.1	PCF85063BTL	3
3.	Hardware set-up	4
3.1	General requirements for the RTC PCF85063BTL	4
3.2	Demo board OM11059	5
4.	Software set-up	6
4.1	Functionality	6
4.2	System testing	6
4.3	Software instructions for setting the clock	7
4.3.1	Setting the time	7
4.3.2	Reading the clock	7
5.	RTC tuning	8
5.1	Frequency tuning	8
6.	Legal information	10
6.1	Definitions	10
6.2	Disclaimers	10
6.3	Trademarks	10
7.	List of figures	11
8.	Contents	12

Please be aware that important notices concerning this document and the product(s) described herein, have been included in the section 'Legal information'.

© NXP B.V. 2015.

All rights reserved.

For more information, please visit: <http://www.nxp.com>
For sales office addresses, please send an email to: salesaddresses@nxp.com

Date of release: 12 February 2015

Document identifier: UM10699