

MATERIAL NO.	ENGINEERING NO.	DESCRIPTION	PRODUCT LENGTH
1301430155	14W48A143	14W48 W/25 14-3SO 15W48	25 FT +12.0/-0.0 IN
1301430156	14W48D143	14W48 W/100 14-3SO 15W48	100 FT +24.0/-0.0 IN

NEMA 6-20; 20A 250V; 2-POLE/3-WIRE

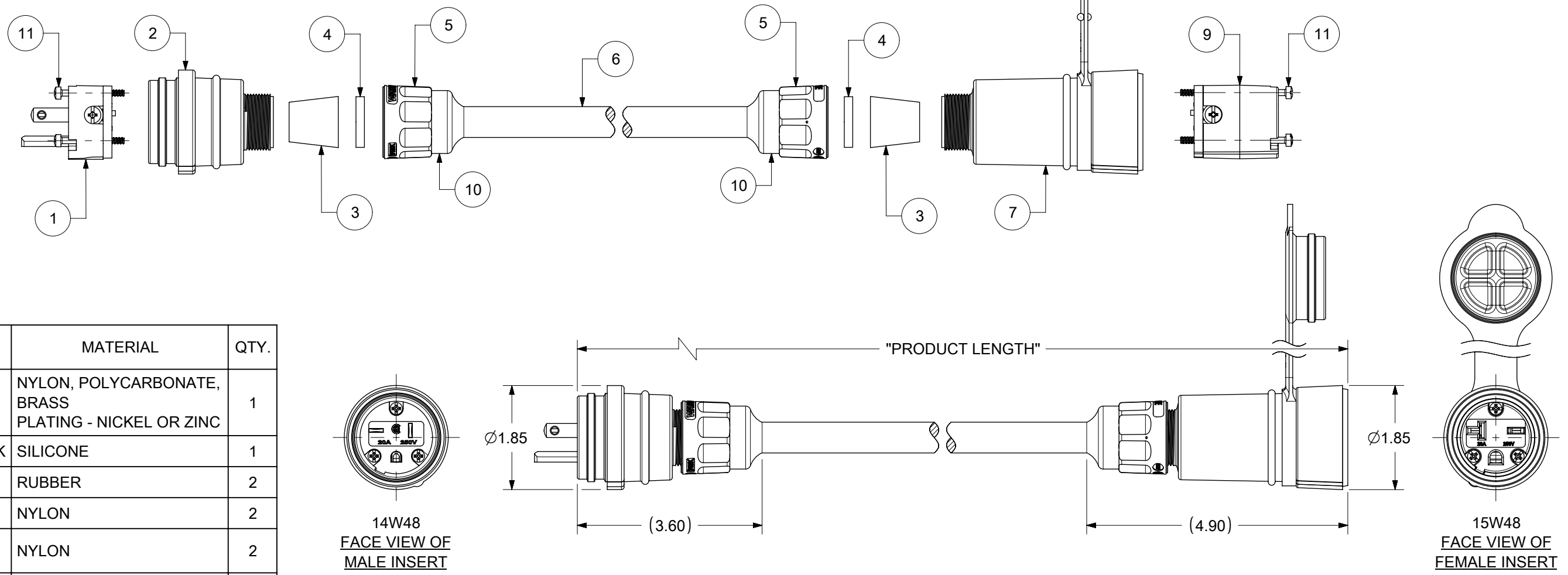

ITEM NO.	DESCRIPTION	MATERIAL	QTY.
1	MALE INSERT ASSY.	NYLON, POLYCARBONATE, BRASS PLATING - NICKEL OR ZINC	1
2	WATERTITE - MALE HUSK	SILICONE	1
3	GROMMET	RUBBER	2
4	FRICITION RING	NYLON	2
5	COMPRESSION NUT YELLOW	NYLON	2
6	YELLOW SOOW CORD	COPPER WIRE	1
7	WATERTITE - FEMALE HUSK	SILICONE	1
8	CLOSURE CAP YELLOW	SILICONE	1
9	FEMALE INSERT ASSY.	NYLON, POLYCARBONATE, BRASS PLATING - NICKEL OR ZINC	1
10	CABLE GLOVE	SILICONE	2
11	RETAINING SCREW	STAINLESS STEEL	6

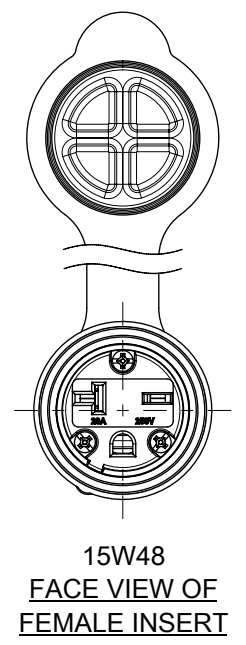
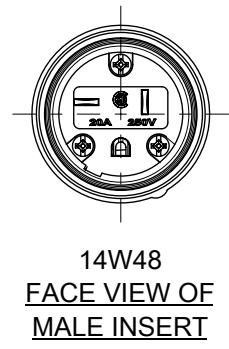

SYMBOLS		THIS DRAWING CONTAINS INFORMATION THAT IS PROPRIETARY TO MOLEX ELECTRONIC TECHNOLOGIES, LLC AND SHOULD NOT BE USED WITHOUT WRITTEN PERMISSION	
▽ = 0	INCH	SCALE	NTS
▽ = 0	GENERAL TOLERANCES (UNLESS SPECIFIED)		CURRENT REV DESC: NEW SALE DRAWING CREATED.
▽ = 0	ANGULAR TOL	±	°
▽ = 0	4 PLACES	±	EC NO: 620468
▽ = 0	3 PLACES	±	DRWN: PPURSUTANDEL 2019/07/05
▽ = 0	2 PLACES	±	CHK'D: DNGUYEN62 2019/08/07
▽ = 0	1 PLACE	±	APPR: HKNEELAND 2020/05/19
▽ = 0	0 PLACES	±	INITIAL REVISION:
▽ = 0	DRAFT WHERE APPLICABLE MUST REMAIN WITHIN DIMENSIONS		THIRD ANGLE PROJECTION
▽ = 0	DRAWING		SERIES
B-SIZE		130143	MATERIAL NUMBER
SEE TABLE		GENERAL MARKET	CUSTOMER
1 OF 1		SHEET NUMBER	

molex

WATERTITE CORDSET
PLUG AND CONNECTOR WITH CORD

PRODUCT CUSTOMER DRAWING

DOCUMENT NUMBER	DOC TYPE	DOC PART	REVISION
1301430155	PSD	000	A