



ELECTRONICS, INC.
 44 FARRAND STREET
 BLOOMFIELD, NJ 07003
 (973) 748-5089
<http://www.nteinc.com>

NTE3075 Bright Red LED Display 2-Digit .560 Inch RHDP

Features:

- Common Cathode
- High Performance GaAsP
- Large, Easy to Read Digits
- Fast Switching – Excellent for Multiplexing
- Low Power Consumption
- Bold Solid Segments that are Highly Legible
- Solid State Reliability – Long Operation Life
- Rugged Plastic Construction
- Directly Compatible with Integrated Circuits
- High Brightness with High Contrast
- Wide Angle Viewing: 150°
- Low Forward Voltage
- Two-Digit Package Simplifies Alignment & Assembly

Applications:

- Digital Readout Displays
- Instrument Panels
- Point-of-Safe Equipment
- Digital Clocks
- TV and Radios

Absolute Maximum Ratings:

Power Dissipation ($T_A = +25^\circ\text{C}$), P_D	45mW
Derate Linearly from 50°C	-13.7mW/ $^\circ\text{C}$
Continuous Forward Current, I_F	
Total	480mA
Per segment	15mA
Reverse Voltage (Per Segment and Decimal Point), V_R	5V
Operating Temperature Range, T_{opr}	-40° to $+85^\circ\text{C}$
Storage Temperature Range, T_{stg}	-40° to $+100^\circ\text{C}$
Lead Temperature (During Soldering for 5sec, Note 1 and Note 2), T_L	$+260^\circ\text{C} \pm 5^\circ\text{C}$
Thermal Resistance, Junction-to-Ambient, R_{thJA}	160 $^\circ\text{C}/\text{W}$
Wavelength Temperature Coefficient (Case Temperature)	3.0 $\lambda/^\circ\text{C}$
Forward Voltage Temperature Coefficient	-2.0mV/ $^\circ\text{C}$

Note 1. Leads of the device immersed to 1/16 inch from the body. Maximum device surface temperature is $+140^\circ\text{C}$.

Note 2. For flux removal, Freon TF, Freon TE, Isoproponal or water may be used up to their boiling points.



Electrical-Optical Characteristics: (Per Diode, $T_A = +25^\circ\text{C}$ unless otherwise specified)

Parameter	Test Conditions	Min	Typ	Max	Unit
Luminous Intensity, Digit Average	$I_F = 10\text{mA}$, Note 3	125	420	-	μcd
Peak Forward Current	Duty 1/10 @ 1kHz	-	-	50	mA
Peak Emission Wavelength		-	697	-	nm
Spectral Line Half Width		-	20	-	nm
Forward Voltage Segment	$I_F = 20\text{mA}$	-	-	2	V
Decimal Point	$I_F = 20\text{mA}$	-	-	2	V
Dynamic Resistance Segment	$I_F = 20\text{mA}$	-	2	-	Ω
Decimal Point	$I_F = 20\text{mA}$	-	2	-	Ω
Capacitance Segment	$V = 0$	-	35	-	pF
Decimal Point	$V = 0$	-	35	-	pF
Reverse Current Segment	$V_R = 5\text{V}$	-	-	100	μA
Decimal Point	$V_R = 5\text{V}$	-	-	100	μA

Note 5. The digit average Luminous Intensity is obtained by summing the Luminous Intensity of each segment and dividing the total number of segment as measured with a Photo Research Corp. "SPECTRA" Microcandela Meter (Model IV-D). Intensity will not vary more than $\pm 33.3\%$ between all segments within a digit.

Pin Connection Diagram

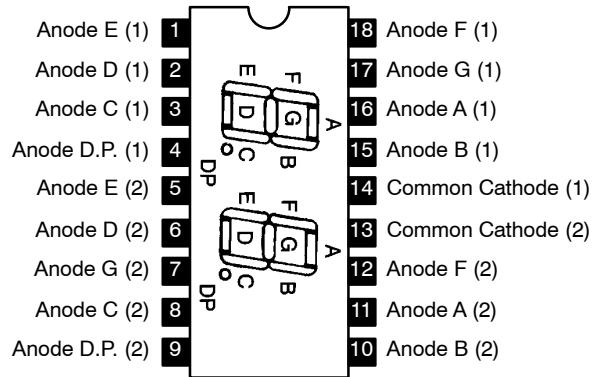

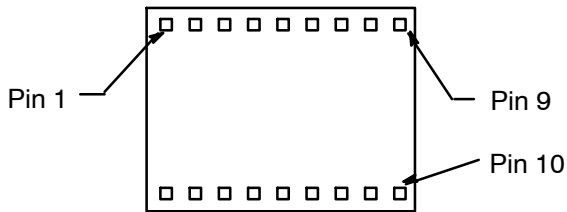
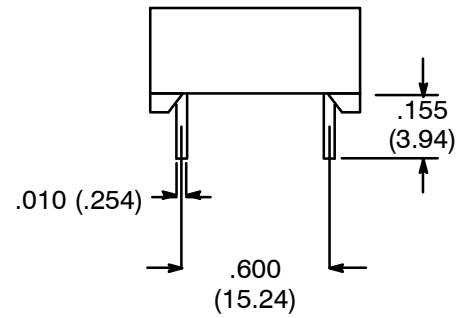
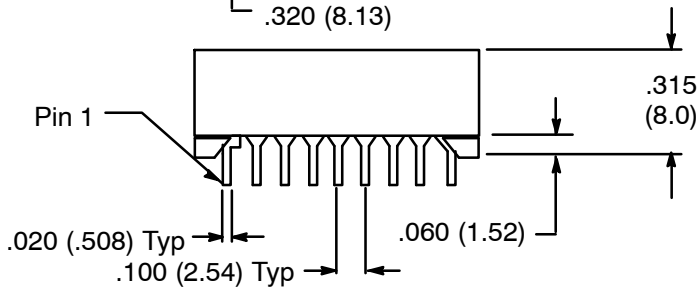
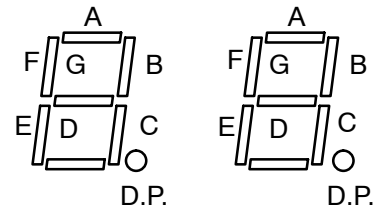
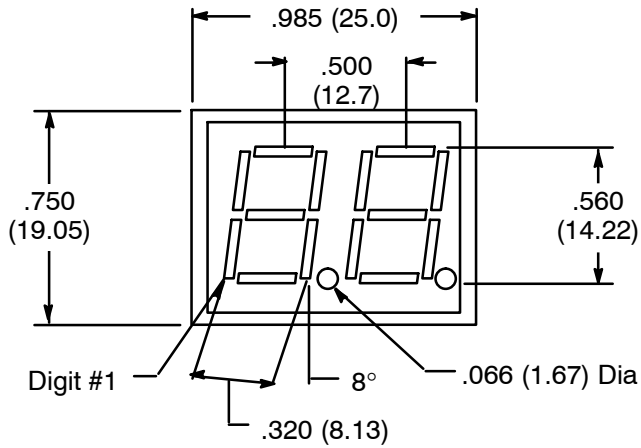

Bottom View