

ORDER NO.	WOODHEAD NO.	COLOR
130145-0023	26T82	BLACK

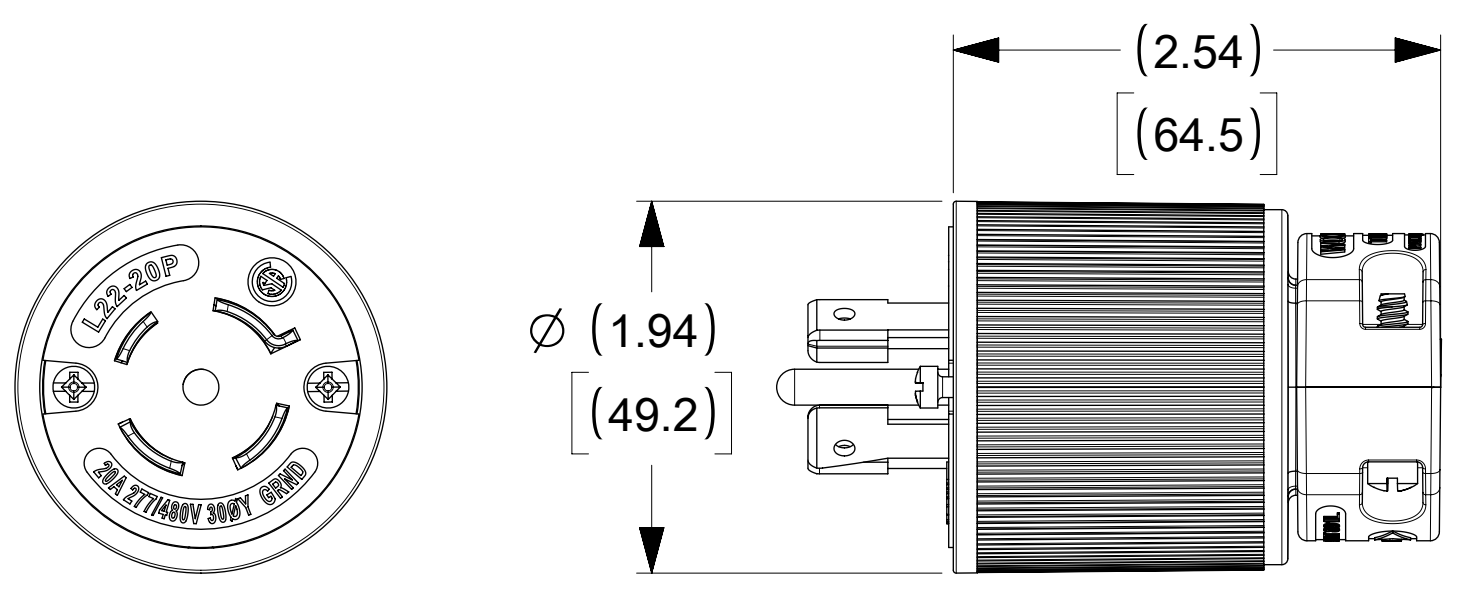

FACE VIEW

WIRING TERMINATION

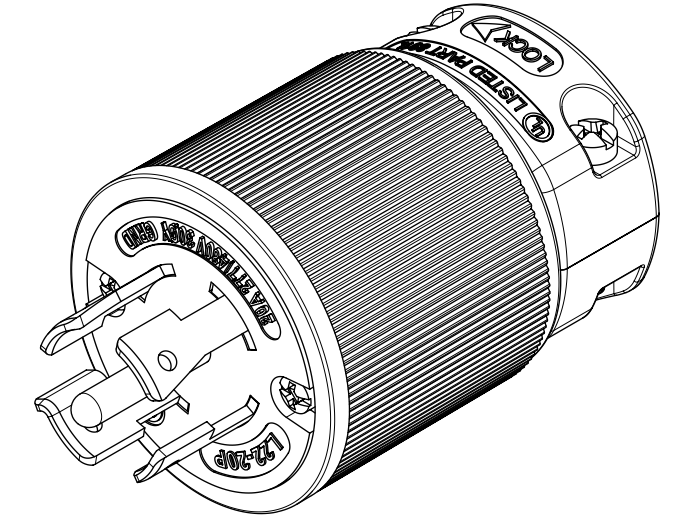
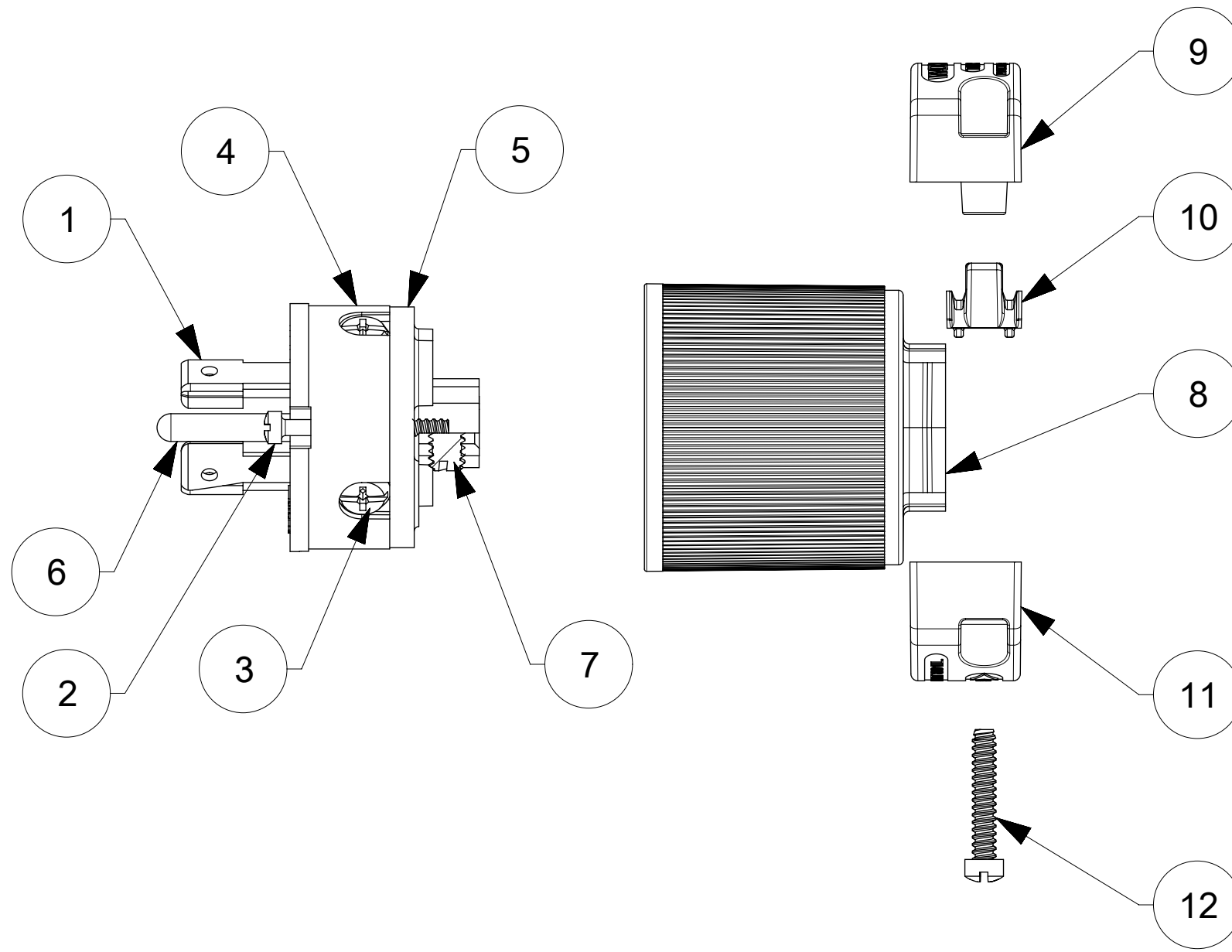
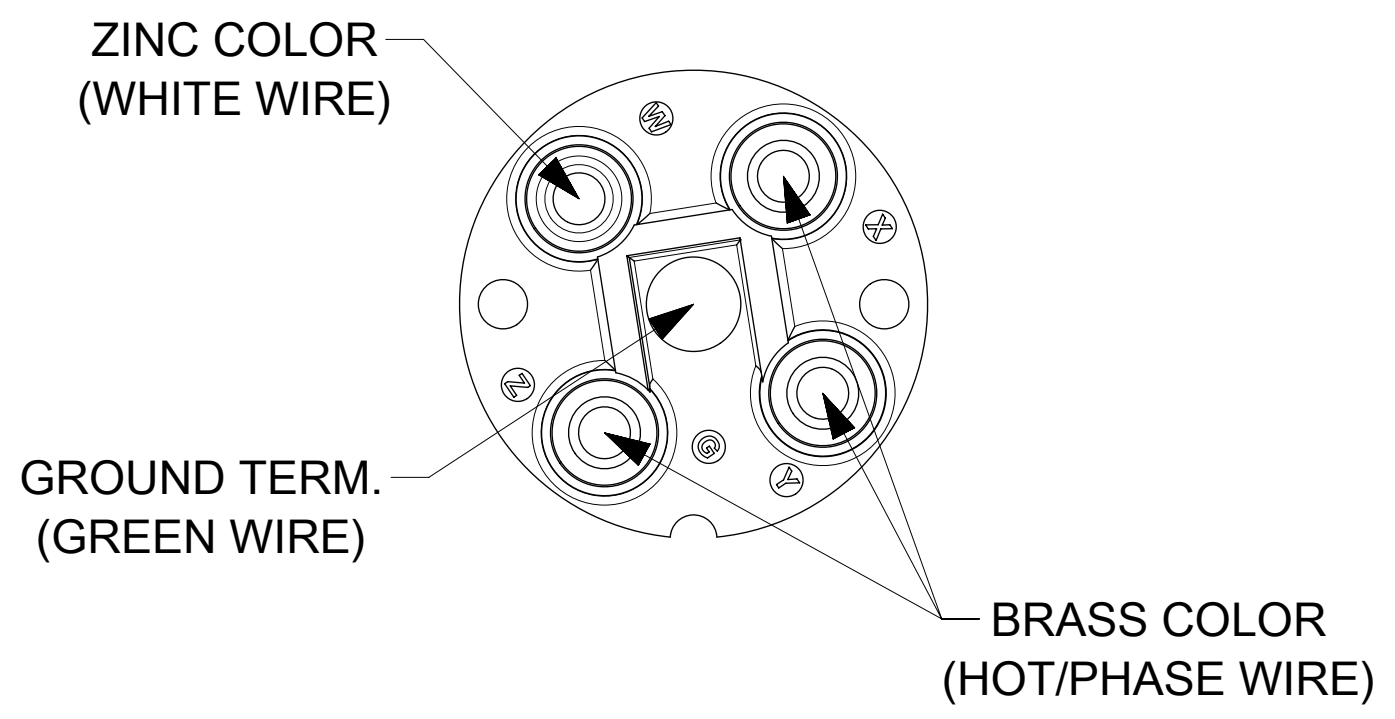

ITEM NO.	DESCRIPTIONS	MATERIAL	QTY.
1	BLADES	BRASS, NICKEL PLATED	4
2	RETAINING SCREWS	STAINLESS STEEL	2
3	TERMINAL SCREWS/CLAMP ASSEMBLY	BRASS, ZINC PLATED	4
4	INSERT	NYLON	1
5	TERMINAL COVER	POLYCARBONATE	1
6	GROUND PIN	BRASS, NICKEL PLATED	1
7	SET SCREW	STAINLESS STEEL	1
8	HOUSING	NYLON	1
9	CLAMP CORD MALE	NYLON	1
10	CLAMP CORD INSERT	NYLON	1
11	CLAMP CORD FEMALE	NYLON	1
12	RETAINING SCREWS	STAINLESS STEEL	2

SYMBOLS DIMENSION UNITS: INCH[MM] SCALE: NTS CURRENT REV DESC: NEW RELEASE GENERAL TOLERANCES (UNLESS SPECIFIED): 4 PLACES ± ± 3 PLACES ± ± 2 PLACES ± ± 1 PLACE ± ± 0 PLACES ± ± ANGULAR TOL ± ° DRAFT WHERE APPLICABLE MUST REMAIN WITHIN DIMENSIONS THIRD ANGLE PROJECTION DRAWING SERIES: C-SIZE 130145	THIS DRAWING CONTAINS INFORMATION THAT IS PROPRIETARY TO MOLEX ELECTRONIC TECHNOLOGIES, LLC AND SHOULD NOT BE USED WITHOUT WRITTEN PERMISSION		molex SAFEWAY PLUG TURNEX 4P5W L22-20 PRODUCT CUSTOMER DRAWING	
	EC NO: 626991 DRWN: VBASUTHKARP 2018/12/11 CHK'D: DNGUYEN62 2019/12/27 APPR: HKNEELAND 2020/02/04		DOCUMENT NUMBER: 1301450023 DOC TYPE: PSD DOC PART: 000 REVISION: A	
	INITIAL REVISION: DRWN: VBASUTHKARP 2018/12/11 APPR: HKNEELAND 2020/02/04		MATERIAL NUMBER: SEE TABLE CUSTOMER: GENERAL MARKET SHEET NUMBER: 1 OF 1	
	DRAFT WHERE APPLICABLE MUST REMAIN WITHIN DIMENSIONS		THIRD ANGLE PROJECTION	