

THIS DRAWING IS UNPUBLISHED. RELEASED FOR PUBLICATION
 © COPYRIGHT - By - ALL RIGHTS RESERVED.

LOC		DIST		REVISIONS			
P	LTR	DESCRIPTION	DATE	DWN	APVD		
GP	00	E1	REVISED PER ECO-11-004835	11MAR11	RK	HMR	

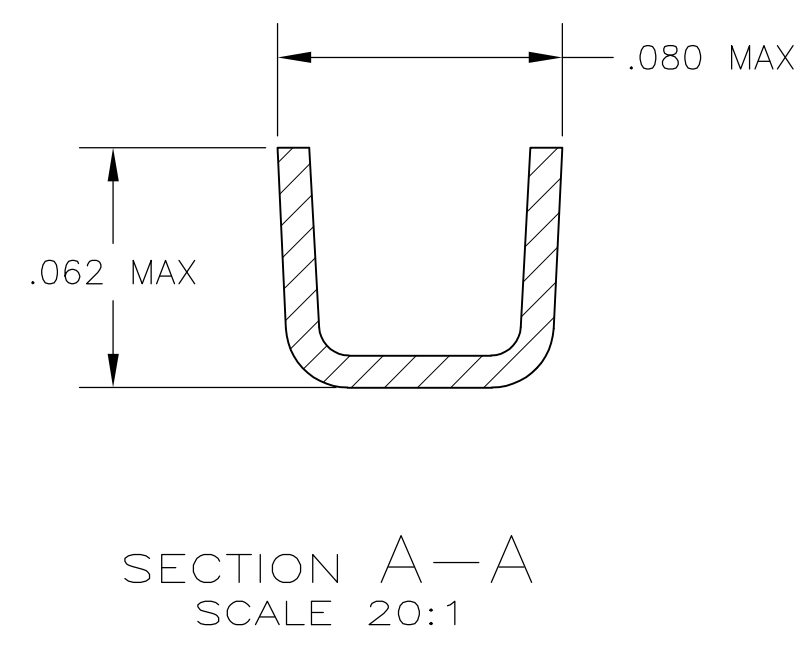
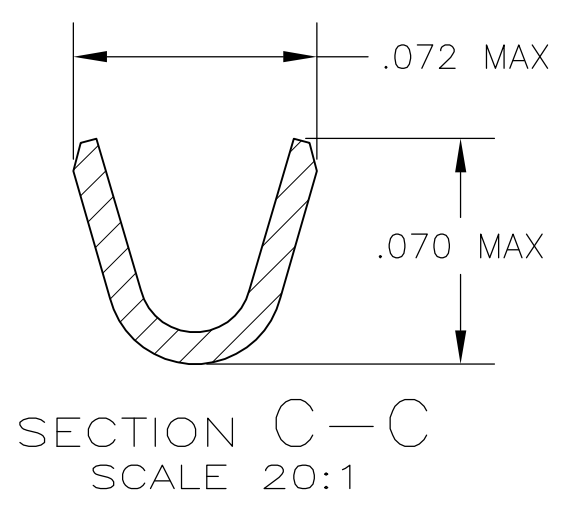
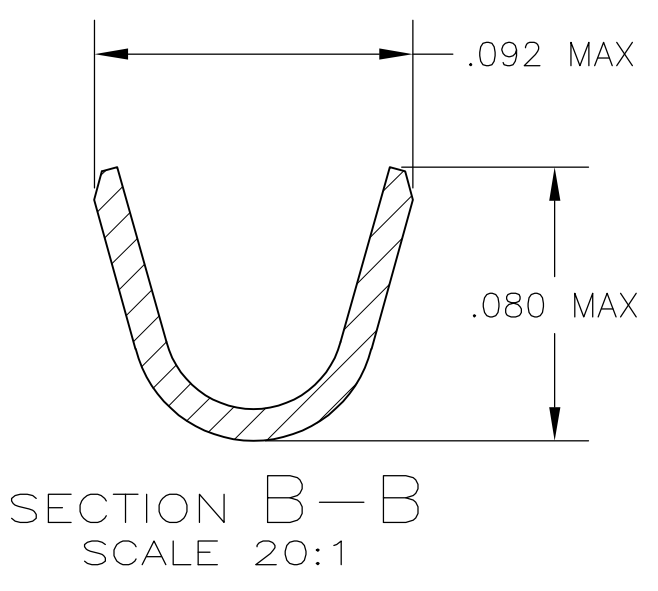
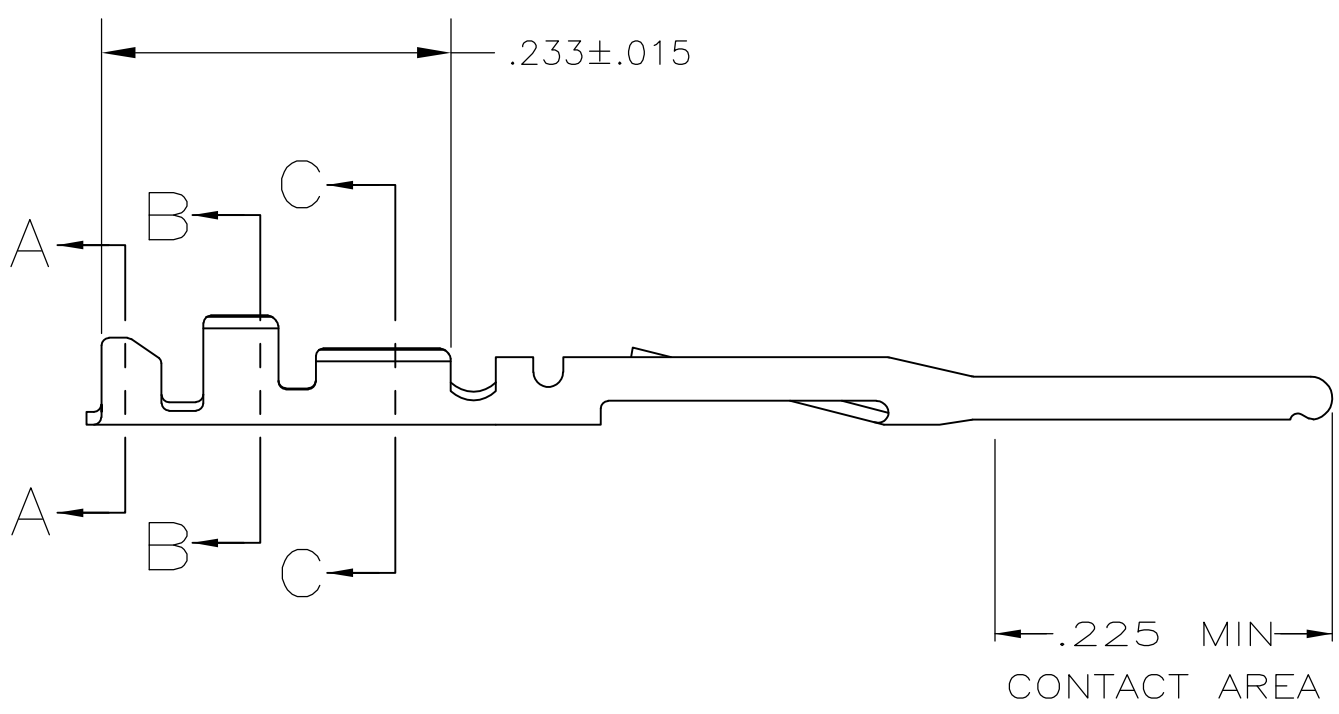
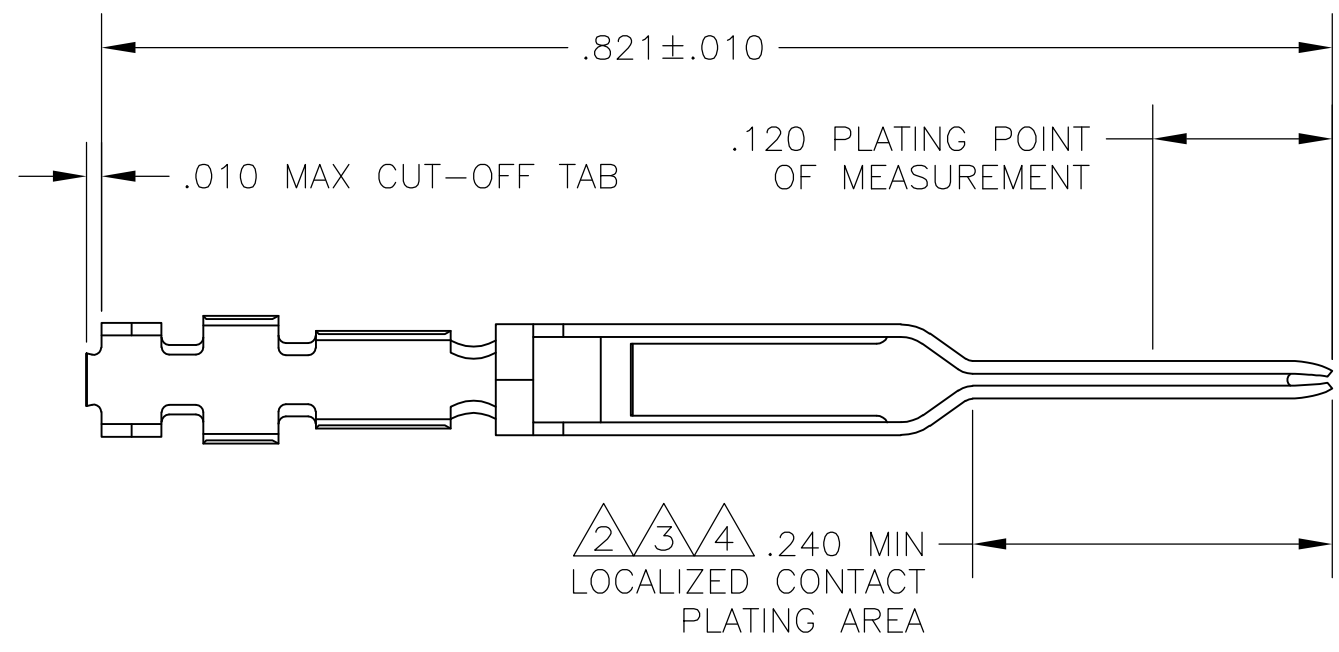

- ① FINISH: .000100 MIN THK BRIGHT TIN LEAD OVER .000050 MIN THK NICKEL ON ENTIRE CONTACT.
- ② FINISH: .000015 THK GOLD IN LOCALIZED CONTACT PLATING AREA AND GOLD FLASH IN OTHER AREAS OVER .000050 MIN NICKEL ON ENTIRE CONTACT.
-OR-
GOLD FLASH OVER PALLADIUM-NICKEL, .000015 MIN TOTAL THK IN LOCALIZED CONTACT PLATING AREA AND GOLD FLASH ON REMAINDER OVER .000050 MIN NICKEL ON ENTIRE CONTACT.
- ③ FINISH: .000030 THK GOLD IN LOCALIZED CONTACT PLATING AREA AND GOLD FLASH IN OTHER AREAS OVER .000050 MIN NICKEL ON ENTIRE CONTACT,
-OR-
GOLD FLASH OVER PALLADIUM-NICKEL, .000030 MIN TOTAL THK IN LOCALIZED CONTACT PLATING AREA AND GOLD FLASH ON REMAINDER OVER .000050 MIN NICKEL ON ENTIRE CONTACT.
- ④ FINISH: .000050 THK GOLD IN LOCALIZED CONTACT PLATING AREA AND GOLD FLASH IN OTHER AREAS OVER .000050 MIN NICKEL ON ENTIRE CONTACT,
-OR-
GOLD FLASH OVER PALLADIUM-NICKEL, .000050 MIN TOTAL THK IN LOCALIZED CONTACT PLATING AREA AND GOLD FLASH ON REMAINDER OVER .000050 MIN NICKEL ON ENTIRE CONTACT.
- 5. FOR 22-26 AWG WIRE WITH AN INSULATION RANGE OF .040-.056 DIA.
- ⑥ FINISH: .000100 MIN THK TIN OVER .000050 MIN THK NICKEL ON ENTIRE CONTACT.

⑥	1-86557-9	1-86561-0
①	1-86557-4	86561-9
④	86557-7	86561-7
②	86557-6	86561-6
③	86557-4	86561-4
FINISH	REELED PART NO	PART NO

THIS DRAWING IS A CONTROLLED DOCUMENT.		DWN J. GALLUCCI 6-27-89	TE TE Connectivity	
DIMENSIONS: INCHES		CHK D.L. ROCKER 6-28-89		
TOLERANCES UNLESS OTHERWISE SPECIFIED:		APVD G.D. MILLER 6-29-89	NAME CONTACT, PIN, .025 SQ ROUND WIRE, .100 CENTERLINE, FFC	
0 PLC ± -		PRODUCT SPEC 108-9024	SIZE A2	
1 PLC ± -		APPLICATION SPEC 114-16003	CAGE CODE 00779	DRAWING NO C=86561
2 PLC ± -		WEIGHT -	RESTRICTED TO -	
3 PLC ± .005		CUSTOMER DRAWING	SCALE 8:1	SHEET 1 of 1
4 PLC ± -			REV E1	
ANGLES ± -				
FINISH PHOS. BRONZE		SEE TABLE		