

THIS DRAWING CONTAINS INFORMATION PROPRIETARY TO RF INDUSTRIES.
 ANY UNAUTHORIZED USE OF THIS DRAWING IS EXPRESSLY PROHIBITED
 WITHOUT WRITTEN PERMISSION FROM RF INDUSTRIES.
 ANY VIOLATION IS PUNISHABLE UNDER U.S. COPYRIGHT LAWS.

ALL DIMENSIONS ARE REFERENCE ONLY

PART NO.

RFN-1022-SR3

REV	DESCRIPTION	DWN	DATE	APPROVED
A	ENGINEERING RELEASE	KMM	2/16/96	R. RICE
B	UPDATE DRAWING FORMAT	CZS	6/20/00	JDMc

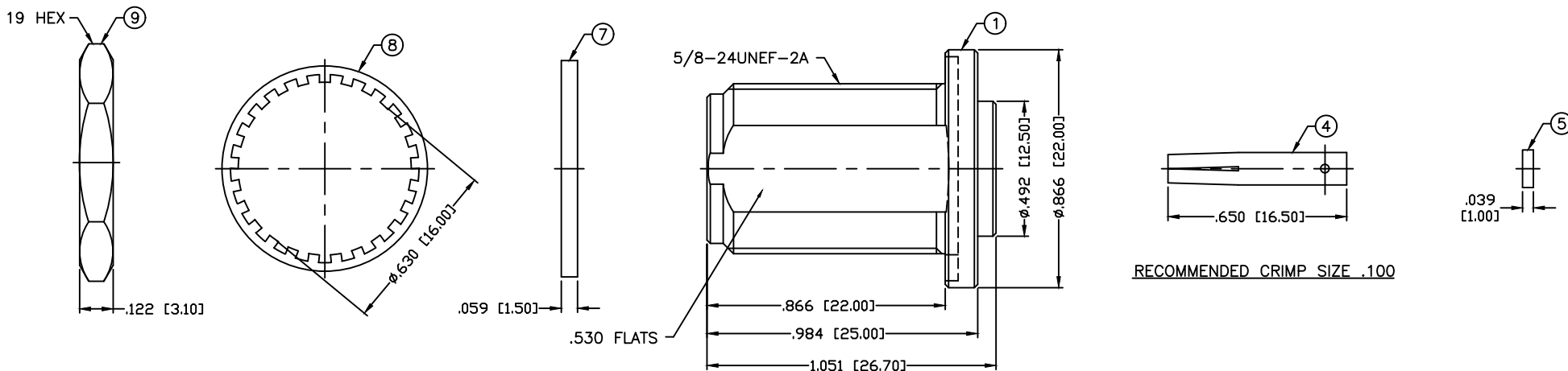

RECOMMENDED CRIMP SIZE .100

SPECIFICATIONS:

IMPEDANCE: 50 OHMS
 FREQUENCY RANGE: 0-11 GHz
 VSWR: 1.3 Max.
 INSERTION LOSS: .06 dB Max. $X\sqrt{f}$ GHz
 WORKING VOLTAGE: 1k V rms @ sea level
 TEMPERATURE RANGE: -65°C TO 165°C
 INSULATION RESISTANCE: 5k M Ohms min.
 FOR .250 Semi Rigid; RG-401/U

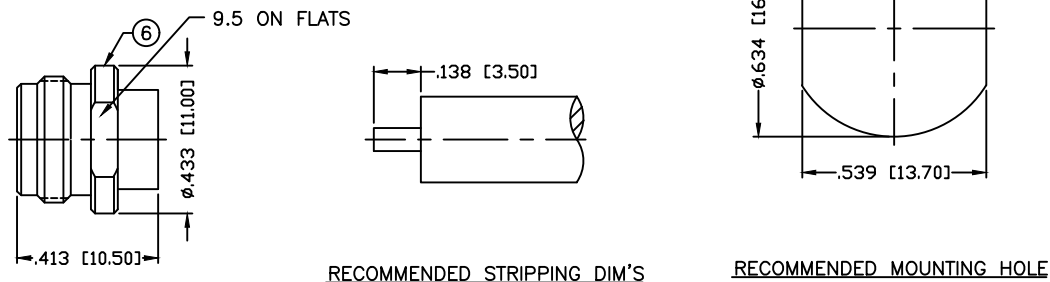

RECOMMENDED STRIPPING DIM'S

RECOMMENDED MOUNTING HOLE

1	BODY	1	BRASS	NICKEL, 100μ"
2	INSULATOR	1	PTFE	---
3	INNER BODY	1	BRASS	NICKEL, 100μ"
4	CONTACT	1	PHOS. BRONZE	GOLD, 3μ"
5	INSULATOR	1	PTFE	---
6	SOLDER NUT	1	BRASS	GOLD, 3μ"
7	GASKET	1	SILICONE	RED
8	LOCK WASHER	1	BRASS	NICKEL, 100μ"
9	HEX NUT	1	BRASS	NICKEL, 100μ"
10				
11				
12				
13				
14				
#	DESCRIPTION	QTY	MATERIAL	FINISH

008974		
DRAWN	C. ZUNIGA	6/20/01
CHECKED		
ORJ DRAWN	K. MAXWELL	2/16/96
APPROVALS	DATE	

UNLESS OTHERWISE SPECIFIED:
 1. REMOVE ALL BURRS
 2. BREAK ALL CORNERS & EDGES .005 R. MAX.
 3. CHAMFER 1ST & LAST THREADS 45°
 4. SURFACE ROUGHNESS 63 FINISH MIL-STD-10
 5. DIAMETERS ON COMMON CENTERS TO BE CONCENTRIC WITHIN .002 T.I.R.
 6. ALL DIMENSIONS ARE AFTER PLATING.

DIMENSIONS ARE IN INCHES AND [MILLIMETERS]
 UNLESS OTHERWISE NOTED TOLERANCES ARE:

DECIMALS	DIAMETER
.XXX±.003 [.08]	.XXX±.001 [.03]
.XX±.005 [.13]	.XX±.003 [.08]

RF connectors
 DIVISION OF RF INDUSTRIES, LTD.

7610 MIRAMAR RD
 SAN DIEGO, CA 92126
 (858) 549-6340
 (858) 549-6345 FAX

N JACK
 BULKHEAD DIRECT SOLDER

SIZE	CABLE GROUP	DWG NO.	REV
A	SR3	RFN-1022-SR3	B

SCALE: NTS CAD FILE OUTLINE SHEET 1 OF 1