

Application Manual

RV-8803-C7

**DTCXO Temp. Compensated
Real-Time Clock Module
with I²C-Bus Interface**

TABLE OF CONTENTS

1. OVERVIEW	5
1.1. GENERAL DESCRIPTION	5
1.2. APPLICATIONS	6
1.3. ORDERING INFORMATION	7
2. BLOCK DIAGRAM	8
2.1. PINOUT	9
2.2. PIN DESCRIPTION	9
2.3. FUNCTIONAL DESCRIPTION	10
2.4. DEVICE PROTECTION DIAGRAM	10
3. REGISTER ORGANIZATION	11
3.1. REGISTER OVERVIEW	11
3.2. CLOCK REGISTERS	13
3.3. CALENDAR REGISTERS	14
3.4. ALARM REGISTERS	16
3.5. PERIODIC COUNTDOWN TIMER CONTROL REGISTERS	18
3.6. EXTENSION REGISTER	19
3.7. FLAG REGISTER	20
3.8. CONTROL REGISTER	21
3.9. OFFSET REGISTER	22
3.10. CAPTURE BUFFER/EVENT CONTROL REGISTERS	23
3.11. REGISTER RESET VALUES SUMMARY	25
4. DETAILED FUNCTIONAL DESCRIPTION	26
4.1. POWER ON RESET (POR)	26
4.2. POWER MANAGEMENT	26
4.3. CLOCK SOURCE	26
4.4. INTERRUPT OUTPUT	27
4.4.1. SERVICING INTERRUPTS	28
4.5. PERIODIC COUNTDOWN TIMER INTERRUPT FUNCTION	29
4.5.1. PERIODIC COUNTDOWN TIMER DIAGRAM.....	29
4.5.2. USE OF THE PERIODIC COUNTDOWN TIMER.....	30
4.5.3. FIRST PERIOD DURATION	31
4.6. PERIODIC TIME UPDATE INTERRUPT FUNCTION	32
4.6.1. PERIODIC TIME UPDATE DIAGRAM.....	32
4.6.2. USE OF THE PERIODIC TIME UPDATE INTERRUPT	33
4.7. ALARM INTERRUPT FUNCTION	34
4.7.1. ALARM DIAGRAM	34
4.7.2. USE OF THE ALARM INTERRUPT.....	35
4.8. EXTERNAL EVENT FUNCTION	36

4.8.1. EXTERNAL EVENT DIAGRAM	37
4.8.2. USE OF THE EXTERNAL EVENT FUNCTION	38
4.9. CLKOUT FREQUENCY SELECTION	39
4.10. DIGITAL ARCHITECTURE SUMMARY	40
4.11. SYNCHRONICITY BETWEEN $\overline{\text{INT}}$ SIGNALS AND 1 HZ CLKOUT	41
4.12. TIME DATA READ-OUT	42
4.12.1. PROCEDURE	42
4.12.2. METHODE TO CONFIRM CORRECT TIME AND CALENDAR READ-OUT	42
4.13. RESET BIT FUNCTION	43
4.14. ERST BIT FUNCTION	43
5. TEMPERATURE COMPENSATION	44
5.1. FREQUENCIES	44
5.2. TIME ACCURACY VS. TEMPERATURE CHARACTERISTICS	44
5.3. COMPENSATION VALUES	45
5.4. AGING CORRECTION	45
5.5. CLOCKING SCHEME	46
5.6. MEASURING TIME ACCURACY AT CLKOUT PIN	47
5.6.1. MEASURING 1 HZ AT CLKOUT PIN	47
5.7. MEASURING TIME ACCURACY AT $\overline{\text{INT}}$ PIN	48
5.7.1. MEASURING 1 HZ WITH THE PERIODIC TIME UPDATE INTERRUPT FUNCTION	48
6. I²C INTERFACE	49
6.1. BIT TRANSFER	49
6.2. START AND STOP CONDITIONS	49
6.3. DATA VALID	50
6.4. SYSTEM CONFIGURATION	50
6.5. ACKNOWLEDGE	51
6.6. SLAVE ADDRESS	52
6.7. WRITE OPERATION	52
6.8. READ OPERATION AT SPECIFIC ADDRESS	53
6.9. READ OPERATION	54
6.10. FREE-CLOCKING I ² C-BUS	54
7. ELECTRICAL SPECIFICATIONS	55
7.1. ABSOLUTE MAXIMUM RATINGS	55
7.2. OPERATING PARAMETERS	56
7.2.1. TEMPERATURE COMPENSATION AND CURRENT CONSUMPTION	58
7.2.2. 32.768 KHZ ENABLE/DISABLE TIMING	58
7.3. OSCILLATOR PARAMETERS	59
7.3.1. TIME ACCURACY 1 HZ EXAMPLES	60
7.4. POWER ON AC ELECTRICAL CHARACTERISTICS	61

7.5. <i>BACKUP AND RECOVERY</i>	62
7.6. <i>I²C-BUS CHARACTERISTICS</i>	63
8. TYPICAL APPLICATION CIRCUIT.....	64
8.1. <i>OPERATING RV-8803-C7 WITH BACKUP CAPACITOR</i>	64
9. PACKAGE	65
9.1. <i>DIMENSIONS AND SOLDER PAD LAYOUT</i>	65
9.1.1. RECOMMENDED THERMAL RELIEF	65
9.2. <i>MARKING AND PIN #1 INDEX</i>	66
10. MATERIAL COMPOSITION DECLARATION & ENVIRONMENTAL INFORMATION.....	67
10.1. <i>HOMOGENOUS MATERIAL COMPOSITION DECLARATION</i>	67
10.2. <i>MATERIAL ANALYSIS & TEST RESULTS</i>	68
10.3. <i>RECYCLING MATERIAL INFORMATION</i>	69
10.4. <i>ENVIRONMENTAL PROPERTIES & ABSOLUTE MAXIMUM RATINGS</i>	70
11. SOLDERING INFORMATION	71
12. HANDLING PRECAUTIONS FOR MODULES WITH EMBEDDED CRYSTALS.....	72
13. PACKING & SHIPPING INFORMATION	73
14. COMPLIANCE INFORMATION	74
15. DOCUMENT REVISION HISTORY	74

RV-8803-C7

DTCXO Temp. Compensated Real-Time Clock Module with I²C-Bus Interface

1. OVERVIEW

- RTC module with built-in “Tuning Fork” crystal oscillating at 32.768 kHz
- Counters for hundredths of seconds, seconds, minutes, hours, date, month, year and weekday
- Factory calibrated temperature compensation
- Very high Time Accuracy
 - ±1.5 ppm 0 to +50°C
 - ±3.0 ppm -40 to +85°C
 - ±7.0 ppm +85 to +105°C
 - Aging compensation with OFFSET value
- I²C-bus interface (up to 400 kHz)
- Periodic Countdown Timer Interrupt function
- Periodic Time Update Interrupt function (seconds, minutes)
- Alarm Interrupts for weekday or date, hour and minute settings
- External Event Input with Interrupt and Time Stamp function
- Programmable Clock Output for peripheral devices (32.768 kHz, 1024 Hz, 1 Hz) with enable/disable function (CLKOE)
- Automatic leap year correction: 2000 to 2099
- Internal Power-On Reset (POR)
- Low voltage detector
- Wide operating voltage range: 1.5 V to 5.5 V
- Very low current consumption: 240 nA ($V_{DD} = 3.0\text{ V}$, $T_A = 25^\circ\text{C}$)
- Operating temperature range: -40 to +85°C (supports extended range from +85°C to +105°C with limitations)
- Ultra small and compact C7 package size, RoHS-compliant and 100% leadfree: 3.2 x 1.5 x 0.8 mm
- Register compatible with Epson RX-8803SA/LC
- Automotive qualification according to AEC-Q200 available

1.1. GENERAL DESCRIPTION

The RV-8803-C7 is a highly accurate real-time clock/calendar module due to its built-in Thermometer and Digital Temperature Compensation circuitry (DTCXO). The Temperature Compensation circuitry is factory calibrated and results in highest time accuracy of ±3.0 ppm across the temperature range from -40 to +85°C and a time accuracy of ±7.0 ppm for the extended range from +85°C to +105°C, and additionally offers an aging offset correction. The RV-8803-C7 has the smallest package and the lowest current consumption among all temperature compensated RTC modules. Due to its special architecture the RV-8803-C7 provides a very low current consumption of 240 nA.

1.2. APPLICATIONS

The RV-8803-C7 RTC module combines key functions with outstanding performance in an ultra-small ceramic package:

- Factory calibrated Temperature Compensation with temperature measuring every second
- Ultra-Low Power consumption
- Smallest RTC module (embedded XTAL) in an ultra-small 3.2 x 1.5 x 0.8 mm leadfree ceramic package.

These unique features make this product perfectly suitable for many applications:

- Communication: IoT / Wearables / Wireless Sensors and Tags / Handsets
- Automotive: M2M / Navigation & Tracking Systems / Dashboard / Tachometers / Engine Controller
Car Audio & Entertainment Systems
- Metering: E-Meter / Heating Counter / Smart Meters / PV Converter/ Utility metering
- Outdoor: ATM & POS systems / Surveillance & Safety systems / Ticketing Systems
- Medical: Glucose Meter / Health Monitoring Systems
- Safety: Security & Camera Systems / Door Lock & Access Control / Tamper Detection
- Consumer: Gambling Machines / TV & Set Top Boxes / White Goods
- Automation: PLC / Data Logger / Home & Factory Automation / Industrial and Consumer Electronics

1.3. ORDERING INFORMATION

Example: RV-8803-C7 TA QC

Code	Operating temperature range
TA (Standard)	-40 to +85°C 1)

1) Supports extended range from +85°C to 105°C with limitations.

Code	Qualification
QC (Standard)	Commercial Grade
QA	Automotive Grade AEC-Q200

2. BLOCK DIAGRAM

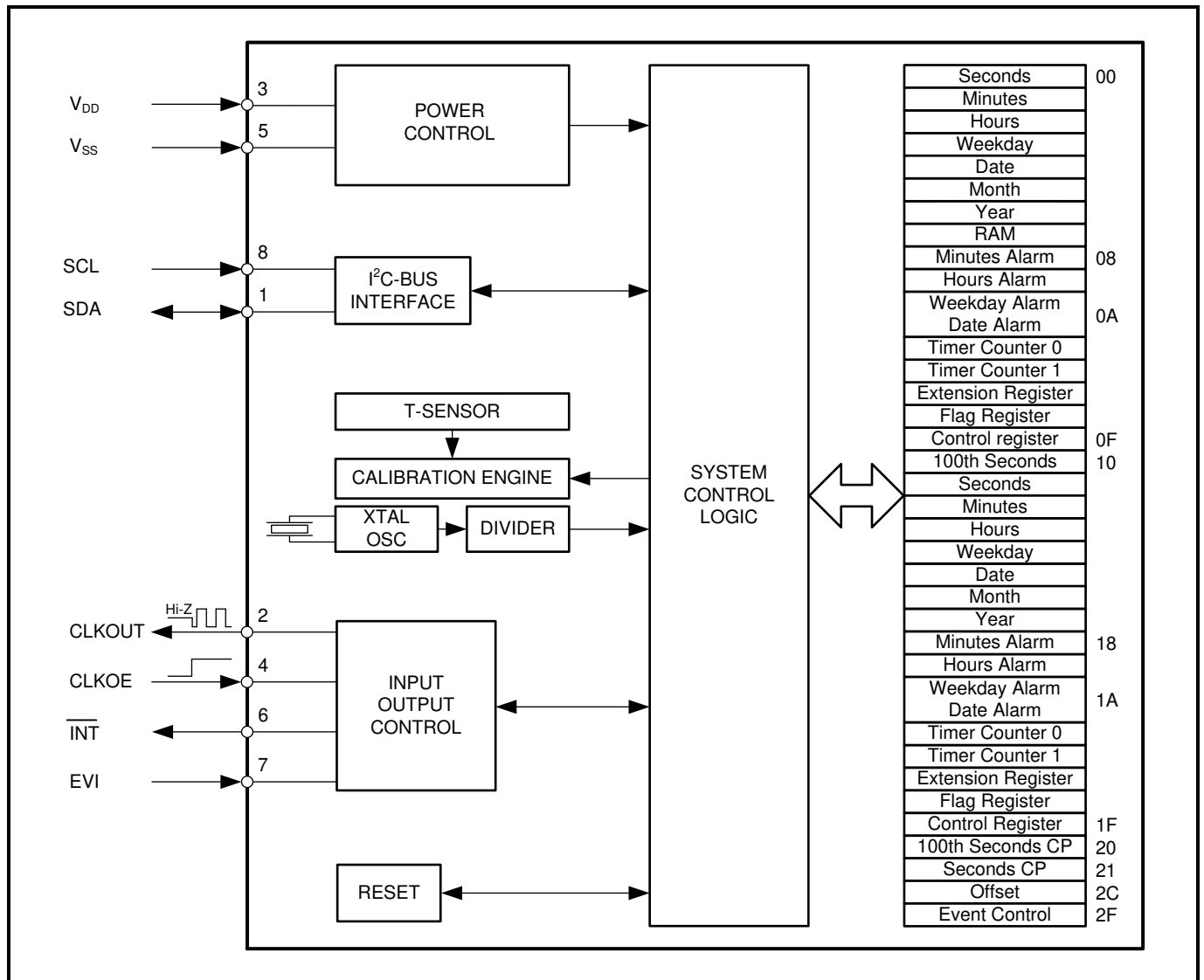

2.1. PINOUT

RV-C7 Package: (top view)

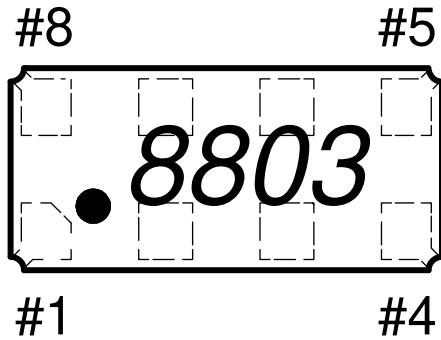

#1	SDA
#2	CLKOUT
#3	V _{DD}
#4	CLKOE
#5	V _{SS}
#6	$\overline{\text{INT}}$
#7	EVI
#8	SCL

2.2. PIN DESCRIPTION

Symbol	Pin #	Description
SDA	1	I ² C Serial Data Input-Output; open-drain; requires pull-up resistor.
CLKOUT	2	Clock Output; push-pull; controlled by CLKOE. If CLKOE is HIGH (V _{DD}), the CLKOUT pin drives the square wave of 32.768 kHz, 1024 Hz or 1 Hz (Default value is 32.768 kHz). When CLKOE is tied to Ground, the CLKOUT pin is high impedance (tri-state).
V _{DD}	3	Power Supply Voltage.
CLKOE	4	Input to enable the CLKOUT pin. If CLKOE is HIGH, the CLKOUT pin is in output mode. When CLKOE is tied to Ground, the CLKOUT pin is stopped and is high impedance (tri-state). This pin should not be left floating.
V _{SS}	5	Ground.
$\overline{\text{INT}}$	6	Interrupt Output; open-drain; active LOW; requires pull-up resistor; Used to output Alarm, Periodic Countdown Timer, Periodic Time Update and External Event Interrupt signals.
EVI	7	External Event Interrupt Input with Time Stamp function. This pin should not be left floating.
SCL	8	I ² C Serial Clock Input; requires pull-up resistor.

2.3. FUNCTIONAL DESCRIPTION

The RV-8803-C7 is a high accurate, ultra-low power CMOS based Real-Time-Clock Module with embedded 32.768 kHz Crystal. The Xtal 32.768 kHz clock itself is not temperature compensated. The very high Time Accuracy and stability of ±3.0 ppm over the temperature range from -40°C to +85°C and of ±7.0 ppm for the extended range from +85°C to +105°C is achieved by the built-in Digital Temperature Compensation circuitry (DTCXO). The factory calibrated correction values are located in the EEPROM and are not accessible for the user. Additionally, there is an Offset Register customer use for aging correction.

The RV-8803-C7 provides standard Clock & Calendar function including seconds, minutes, hours (24), weekdays, date, months, years (with leap year correction) and interrupt functions for an External Event, Periodic Countdown Timer, Periodic Time Update and Alarm. Beside the standard RTC functions, it includes an integrated Temperature Sensor, a Time Stamp function for the External Event Input and 1 Byte of User RAM and offers an I²C-bus (2-wire Interface). Further 2 Bytes can be used as User RAM when the Periodic Countdown Timer is not used (Timer Counter registers 0Bh, 1Bh and 0Ch, 1Ch) and further 3 Bytes when the Alarm function is not used (Alarm registers 08h, 18h; 09h, 19h and 0Ah, 1Ah).

The registers are accessed by selecting a register address and then performing read or write operations. Multiple reads or writes may be executed in a single access, with the address automatically incrementing after each byte. When address is automatically incremented, wrap around occurs from the address FFh to the address 00h (see figure below).

Handling address registers:

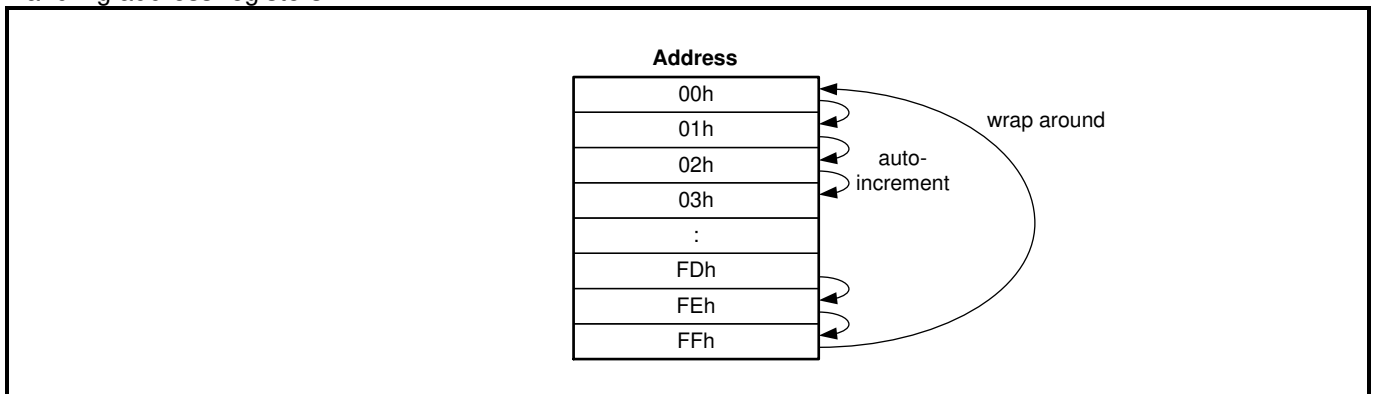

2.4. DEVICE PROTECTION DIAGRAM

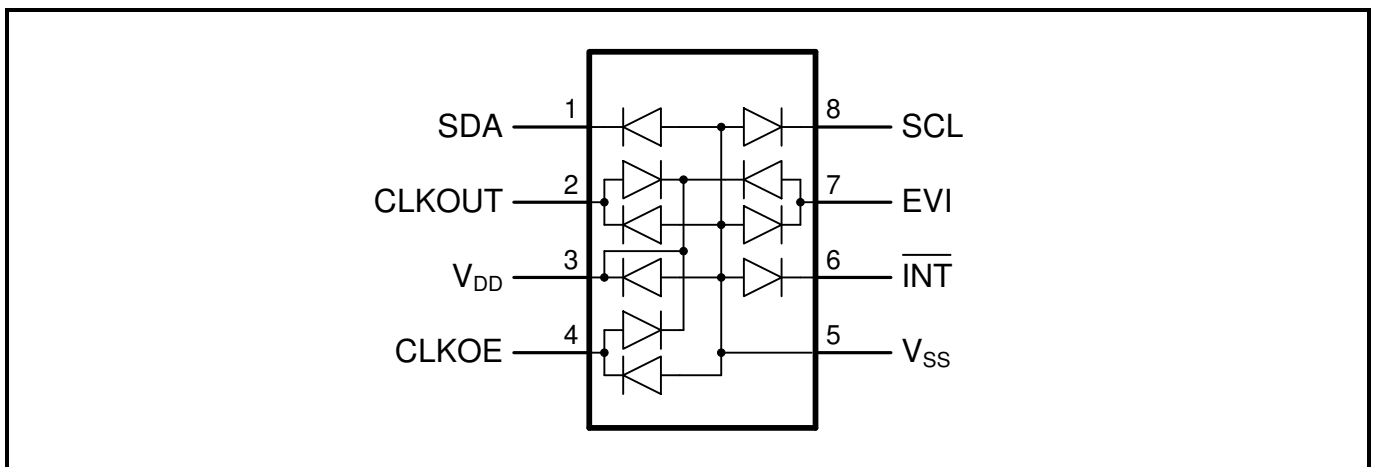

3. REGISTER ORGANIZATION

Registers are accessed by selecting a register address and then performing read or write operations. Multiple reads or writes may be executed in a single access, with the address automatically incrementing after each byte. The following tables Register Definitions (00h to 0Fh), (10h to 1Fh) and (20h to 2Fh) summarize the function of each register. In the table Register Definitions (00h to 0Fh) and (10h to 1Fh) the GPx bits (where x is between 0 and 5) are 6 register bits which may be used as general purpose storage. These bits are not described in the sections below. All of the GPx bits are cleared when the RV-8803-C7 powers up, and they can therefore be used to allow software to determine if a true Power On Reset has occurred, or to hold other initialization data.

- Address 00h to 0Fh: Basic time and calendar register Adds RAM
- Address 10h to 1Fh: Extension register ① Adds 100th Seconds counter
- Address 20h to 2Fh: Extension register ② Capture buffer and Event control

Note: When writing or reading a specific function value into/from the Address range 00h to 0Fh the value will be automatically updated in the Address range 10h to 1Fh and vice versa.

In order to not corrupt the accuracy of the temperature compensation and the Time Stamp (Capture) function on the highest 100th Seconds resolution, it is not possible to freeze the clock and calendar register during read-out process, as it is common practice for other RTC's.

Since the time and calendar registers cannot be frozen, there might be a condition that the time registers are incremented while read-out. To avoid reading corrupted (partially incremented) data, special measures and procedures need to be applied (see TIME DATA READ).

3.1. REGISTER OVERVIEW

After reset, all registers are set according to Table in section REGISTER RESET VALUES SUMMARY.

Register Definitions, Address 00h to 0Fh (Basic time and calendar register):

Address	Function	Bit 7	Bit 6	Bit 5	Bit 4	Bit 3	Bit 2	Bit 1	Bit 0
00h	Seconds	○	40	20	10	8	4	2	1
01h	Minutes	○	40	20	10	8	4	2	1
02h	Hours	○	○	20	10	8	4	2	1
03h	Weekday	○	6	5	4	3	2	1	0
04h	Date	○	○	20	10	8	4	2	1
05h	Month	○	○	○	10	8	4	2	1
06h	Year	80	40	20	10	8	4	2	1
07h	RAM	RAM data							
08h	Minutes Alarm	AE_M	40	20	10	8	4	2	1
09h	Hours Alarm	AE_H	GP0	20	10	8	4	2	1
0Ah	Weekday Alarm	AE_WD	6	5	4	3	2	1	0
	Date Alarm		GP1	20	10	8	4	2	1
0Bh	Timer Counter 0	128	64	32	16	8	4	2	1
0Ch	Timer Counter 1	GP5	GP4	GP3	GP2	2048	1024	512	256
0Dh	Extension Register	TEST	WADA	USEL	TE	FD		TD	
0Eh	Flag Register	○	○	UF	TF	AF	EVF	V2F	V1F
0Fh	Control Register	RESERVED		UIE	TIE	AIE	EIE	○	RESET

○ Read only. Always 0.

Register Definitions, Address 10h to 1Fh (Extension register ①):

Address	Function	Bit 7	Bit 6	Bit 5	Bit 4	Bit 3	Bit 2	Bit 1	Bit 0
10h	100 th Seconds (Read Only)	80	40	20	10	8	4	2	1
11h	Seconds	○	40	20	10	8	4	2	1
12h	Minutes	○	40	20	10	8	4	2	1
13h	Hours	○	○	20	10	8	4	2	1
14h	Weekday	○	6	5	4	3	2	1	0
15h	Date	○	○	20	10	8	4	2	1
16h	Month	○	○	○	10	8	4	2	1
17h	Year	80	40	20	10	8	4	2	1
18h	Minutes Alarm	AE_M	40	20	10	8	4	2	1
19h	Hours Alarm	AE_H	GP0	20	10	8	4	2	1
1Ah	Weekday Alarm	AE_WD	6	5	4	3	2	1	0
	Date Alarm		GP1	20	10	8	4	2	1
1Bh	Timer Counter 0	128	64	32	16	8	4	2	1
1Ch	Timer Counter 1	GP5	GP4	GP3	GP2	2048	1024	512	256
1Dh	Extension Register	TEST	WADA	USEL	TE	FD		TD	
1Eh	Flag Register	○	○	UF	TF	AF	EVF	V2F	V1F
1Fh	Control Register	RESERVED		UIE	TIE	AIE	EIE	○	RESET

○ Read only. Always 0.

Register Definitions, Address 20h to 2Fh (Extension register ②):

Address	Function	Bit 7	Bit 6	Bit 5	Bit 4	Bit 3	Bit 2	Bit 1	Bit 0
20h	100 th Seconds CP (Read Only)	80	40	20	10	8	4	2	1
21h	Seconds CP (Read Only)	○	40	20	10	8	4	2	1
2Ch	Offset	○	○	OFFSET					
2Fh	Event Control	ECP	EHL	ET		○	○	○	ERST

○ Read only. Always 0.

3.2. CLOCK REGISTERS

10h - 100th Seconds (Read Only)

This register holds the count of hundredths of seconds, in two binary coded decimal (BCD) digits. Values will be from 00 to 99.

Address	Function	Bit 7	Bit 6	Bit 5	Bit 4	Bit 3	Bit 2	Bit 1	Bit 0
10h	100 th Seconds (Read Only)	80	40	20	10	8	4	2	1
	Reset	X	X	X	X	X	X	X	X
Bit	Symbol	Value	Description						
7:0	100 th Seconds (Read Only)	00 to 99	Holds the count of hundredths of seconds, coded in BCD format. The 100 th Seconds register is cleared to 00 when writing to the Seconds register or when setting the RESET bit to 1 or when the ERST bit is 1 in case of an External Event detection on EVI pin.						

00h, 11h - Seconds

This register holds the count of seconds, in two binary coded decimal (BCD) digits. Values will be from 00 to 59.

Addresses	Function	Bit 7	Bit 6	Bit 5	Bit 4	Bit 3	Bit 2	Bit 1	Bit 0
00h, 11h ⁽¹⁾	Seconds	0	40	20	10	8	4	2	1
	Reset	0	X	X	X	X	X	X	X
Bit	Symbol	Value	Description						
7	0	0	Read only. Always 0.						
6:0	Seconds	00 to 59	Holds the count of seconds, coded in BCD format. When writing to the Seconds register the 100 th Seconds register is cleared to 00. When RESET bit is 1 the Seconds register value remains unchanged (1 Hz clock is stopped).						

01h, 12h - Minutes

This register holds the count of minutes, in two binary coded decimal (BCD) digits. Values will be from 00 to 59.

Addresses	Function	Bit 7	Bit 6	Bit 5	Bit 4	Bit 3	Bit 2	Bit 1	Bit 0
01h, 12h ⁽¹⁾	Minutes	0	40	20	10	8	4	2	1
	Reset	0	X	X	X	X	X	X	X
Bit	Symbol	Value	Description						
7	0	0	Read only. Always 0.						
6:0	Minutes	00 to 59	Holds the count of minutes, coded in BCD format.						

02h, 13h - Hours

This register holds the count of hours, in two binary coded decimal (BCD) digits. Values will be from 00 to 23.

Addresses	Function	Bit 7	Bit 6	Bit 5	Bit 4	Bit 3	Bit 2	Bit 1	Bit 0
02h, 13h ⁽¹⁾	Hours	0	0	20	10	8	4	2	1
	Reset	0	0	X	X	X	X	X	X
Bit	Symbol	Value	Description						
7:6	0	0	Read only. Always 0.						
5:0	Hours	00 to 23	Holds the count of hours, coded in BCD format.						

⁽¹⁾ This specific function accessed in Address range 00h to 0Fh is automatically updated in Address range 10h to 1Fh and vice versa.

3.3. CALENDAR REGISTERS

03h, 14h - Weekday

This register holds the current day of the week. Each bit represents one weekday that is assigned by the user. Values will range from 1 to 7. Do not set 1 to more than one bit.

Addresses	Function	Bit 7	Bit 6	Bit 5	Bit 4	Bit 3	Bit 2	Bit 1	Bit 0
03h, 14h ⁽¹⁾	Weekday	○	7	6	5	4	3	2	1
	Reset	0	X	X	X	X	X	X	X
Bit	Symbol	Value	Description						
7	○	0	Read only. Always 0.						
6:0	Weekday	1 to 7	Holds the weekday counter value. Do not set 1 to more than one bit.						
Weekday		Bit 7	Bit 6	Bit 5	Bit 4	Bit 3	Bit 2	Bit 1	Bit 0
Weekday 1		0	0	0	0	0	0	0	1
Weekday 2			0	0	0	0	0	1	0
Weekday 3			0	0	0	0	1	0	0
Weekday 4			0	0	0	1	0	0	0
Weekday 5			0	0	1	0	0	0	0
Weekday 6			0	1	0	0	0	0	0
Weekday 7			1	0	0	0	0	0	0

04h, 15h – Date

This register holds the current day of the month, in two binary coded decimal (BCD) digits. Values will range from 00 to 31. The Reset value **XX** after POR has to be replaced by a valid initial value (01 to 31). Leap years are correctly handled from 2000 to 2099.

Addresses	Function	Bit 7	Bit 6	Bit 5	Bit 4	Bit 3	Bit 2	Bit 1	Bit 0
04h, 15h ⁽¹⁾	Date	○	○	20	10	8	4	2	1
	Reset	0	0	X	X	X	X	X	X
Bit	Symbol	Value	Description						
7:6	○	0	Read only. Always 0.						
5:0	Date	00 to 31	Holds the current date of the month, coded in BCD format. The Reset value XX after POR has to be replaced by a valid initial value (01 to 31).						

05h, 16h - Month

This register holds the current month, in two binary coded decimal (BCD) digits. Values will range from 01 to 12.

Addresses	Function	Bit 7	Bit 6	Bit 5	Bit 4	Bit 3	Bit 2	Bit 1	Bit 0
05h, 16h ⁽¹⁾	Month	○	○	○	10	8	4	2	1
	Reset	0	0	0	X	X	X	X	X
Bit	Symbol	Value	Description						
7:5	○	0	Read only. Always 0.						
4:0	Month	01 to 12	Holds the current month, coded in BCD format.						

⁽¹⁾ This specific function accessed in Address range 00h to 0Fh is automatically updated in Address range 10h to 1Fh and vice versa.

06h, 17h - Year

This register holds the current year, in two binary coded decimal (BCD) digits. Values will range from 00 to 99. Leap years are correctly handled from 2000 to 2099.

Addresses	Function	Bit 7	Bit 6	Bit 5	Bit 4	Bit 3	Bit 2	Bit 1	Bit 0
06h, 17h ⁽¹⁾	Year	80	40	20	10	8	4	2	1
	Reset	X	X	X	X	X	X	X	X
Bit	Symbol	Value	Description						
7:0	Year	00 to 99	Holds the current year, coded in BCD format.						

07h - RAM

This register holds the bits for general purpose use.

Address	Function	Bit 7	Bit 6	Bit 5	Bit 4	Bit 3	Bit 2	Bit 1	Bit 0
07h	RAM	RAM data							
	Reset	0	0	0	0	0	0	0	0
Bit	Symbol	Value	Description						
7:0	RAM	00h to FFh	User RAM						

⁽¹⁾ This specific function accessed in Address range 00h to 0Fh is automatically updated in Address range 10h to 1Fh and vice versa.

3.4. ALARM REGISTERS

08h, 18h – Minutes Alarm

This register holds the Minutes Alarm Enable bit AE_M and the alarm value for minutes, in two binary coded decimal (BCD) digits. Values will range from 00 to 59.

Addresses	Function	Bit 7	Bit 6	Bit 5	Bit 4	Bit 3	Bit 2	Bit 1	Bit 0
08h, 18h ⁽¹⁾	Minutes Alarm	AE_M	40	20	10	8	4	2	1
	Reset	0	0	0	0	0	0	0	0
Bit	Symbol	Value	Description						
7	AE_M	Minutes Alarm Enable bit. Enables alarm together with AE_H and AE_WD (see USE OF THE ALARM INTERRUPT).							
		0	Minutes Alarm is enabled. – Default value						
		1	Minutes Alarm is disabled.						
6:0	Minutes Alarm	00 to 59	Holds the alarm value for minutes, coded in BCD format.						

09h, 19h – Hours Alarm

This register holds the Hours Alarm Enable bit AE_H and the alarm value for hours, in two binary coded decimal (BCD) digits. Values will range from 00 to 23.

Addresses	Function	Bit 7	Bit 6	Bit 5	Bit 4	Bit 3	Bit 2	Bit 1	Bit 0
09h, 19h ⁽¹⁾	Hours Alarm	AE_H	GP0	20	10	8	4	2	1
	Reset	0	0	0	0	0	0	0	0
Bit	Symbol	Value	Description						
7	AE_H	Hours Alarm Enable bit. Enables alarm together with AE_M and AE_WD (see USE OF THE ALARM INTERRUPT).							
		0	Hours Alarm is enabled. – Default value						
		1	Hours Alarm is disabled.						
6	GP0	0 or 1	Register bit for general purpose use.						
5:0	Hours Alarm	00 to 23	Holds the alarm value for hours, coded in BCD format.						

⁽¹⁾ This specific function accessed in Address range 00h to 0Fh is automatically updated in Address range 10h to 1Fh and vice versa.

0Ah, 1Ah – Weekday/Date Alarm

This register holds the Weekday/Date Alarm Enable bit AE_WD. If the WADA bit is 0 (Bit 6 in Register 0Dh, 1Dh), it holds the alarm value for the day of the week (weekdays assigned by the user). Multiple weekdays can be selected. Values will range from 0000001 to 1111111. If the WADA bit is 1, it holds the alarm value for the date, in two binary coded decimal (BCD) digits. Values will range from 01 to 31. Leap years are correctly handled from 2000 to 2099.

Weekday Alarm when WADA = 0 (Bit 6 in Register 0Dh, 1Dh)

Addresses	Function	Bit 7	Bit 6	Bit 5	Bit 4	Bit 3	Bit 2	Bit 1	Bit 0
0Ah, 1Ah ⁽¹⁾	Weekday Alarm	AE_WD	7	6	5	4	3	2	1
	Reset	0	0	0	0	0	0	0	0

Bit	Symbol	Value	Description
7	AE_WD		Weekday/Date Alarm Enable bit. Enables alarm together with AE_M and AE_H (see USE OF THE ALARM INTERRUPT).
		0	Weekday/Date Alarm is enabled. – Default value
		1	Weekday/Date Alarm is disabled.
6:0	Weekday Alarm	0000000 to 1111111	Holds the weekday alarm value. Multiple days can be selected.

Weekday Alarm	Bit 7	Bit 6	Bit 5	Bit 4	Bit 3	Bit 2	Bit 1	Bit 0	
Any weekday selected. – Default value	0 or 1	0	0	0	0	0	0	0	
Weekday 1 Alarm		0	0	0	0	0	0	1	
Weekday 2 Alarm		0	0	0	0	0	0	1	0
Weekday 3 Alarm		0	0	0	0	0	1	0	0
Weekday 4 Alarm		0	0	0	1	0	0	0	0
Weekday 5 Alarm		0	0	1	0	0	0	0	0
Weekday 6 Alarm		0	1	0	0	0	0	0	0
Weekday 7 Alarm		1	0	0	0	0	0	0	0

Date Alarm when WADA = 1 (Bit 6 in Register 0Dh, 1Dh)

Addresses	Function	Bit 7	Bit 6	Bit 5	Bit 4	Bit 3	Bit 2	Bit 1	Bit 0
0Ah, 1Ah ⁽¹⁾	Date Alarm	AE_WD	GP1	20	10	8	4	2	1
	Reset	0	0	0	0	0	0	0	0

Bit	Symbol	Value	Description
7	AE_WD		Weekday/Date Alarm Enable bit. Enables alarm together with AE_M and AE_H (see USE OF THE ALARM INTERRUPT).
		0	Weekday/Date Alarm is enabled. – Default value
		1	Weekday/Date Alarm is disabled.
6	GP1	0 or 1	Register bit for general purpose use.
5:0	Date Alarm	01 to 31	Holds the alarm value for the date, coded in BCD format. The Reset value 00 after POR has to be replaced by a valid value (01 to 31).

⁽¹⁾ This specific function accessed in Address range 00h to 0Fh is automatically updated in Address range 10h to 1Fh and vice versa.

3.5. PERIODIC COUNTDOWN TIMER CONTROL REGISTERS

0Bh, 1Bh – Timer Counter 0

This register is used to set the lower 8 bits of the Timer Value (preset value) for the Periodic Countdown Timer.

Addresses	Function	Bit 7	Bit 6	Bit 5	Bit 4	Bit 3	Bit 2	Bit 1	Bit 0
0Bh, 1Bh ⁽¹⁾	Timer Counter 0	128	64	32	16	8	4	2	1
	Reset	0	0	0	0	0	0	0	0
Bit	Symbol	Value	Description						
7:0	Timer Counter 0	00h to FFh	The Timer Value for the Periodic Countdown Timer (lower 8 bit) (see USE OF THE PERIODIC COUNTDOWN TIMER). When read, only the preset value is returned and not the actual value.						

0Ch, 1Ch – Timer Counter 1

This register is used to set the upper 4 bits of the Timer Value (preset value) for the Periodic Countdown Timer.

Addresses	Function	Bit 7	Bit 6	Bit 5	Bit 4	Bit 3	Bit 2	Bit 1	Bit 0
0Ch, 1Ch ⁽¹⁾	Timer Counter 1	GP5	GP4	GP3	GP2	2048	1024	512	256
	Reset	0	0	0	0	0	0	0	0
Bit	Symbol	Value	Description						
7	GP5	0 or 1	Register bit for general purpose use.						
6	GP4	0 or 1	Register bit for general purpose use.						
5	GP3	0 or 1	Register bit for general purpose use.						
4	GP2	0 or 1	Register bit for general purpose use.						
3:0	Timer Counter 1	0h to Fh	The Timer Value for the Periodic Countdown Timer (upper 4 bit) (see USE OF THE PERIODIC COUNTDOWN TIMER). When read, only the preset value is returned and not the actual value.						

⁽¹⁾ This specific function accessed in Address range 00h to 0Fh is automatically updated in Address range 10h to 1Fh and vice versa.

Countdown Period in seconds:

$$\text{Countdown Period} = \frac{\text{Timer Value}}{\text{Timer Clock Frequency}}$$

3.6. EXTENSION REGISTER

0Dh, 1Dh – Extension Register

This register is used to specify the target for the Alarm Interrupt function and the Periodic Time Update Interrupt function and to select or set operations for the Periodic Countdown Timer.

Addresses	Function	Bit 7	Bit 6	Bit 5	Bit 4	Bit 3	Bit 2	Bit 1	Bit 0
0Dh, 1Dh ⁽¹⁾	Extension Register	TEST	WADA	USEL	TE	FD		TD	
	Reset	0	0	0	0	0	0	0	0
Bit	Symbol	Value	Description						
7	TEST	0	This is a manufacturer's test bit. Its value should always be 0. Avoid writing a 1 to this bit when writing in this register. Zero for normal operation.						
6	WADA	Weekday Alarm / Date Alarm selection bit. This bit is used to specify either the Weekday or Date as the source for the Alarm Interrupt function (see USE OF THE ALARM INTERRUPT).							
		0	Weekday is the source for the Alarm Interrupt function. – Default value						
		1	Date is the source for the Alarm Interrupt function.						
5	USEL	Update Interrupt Select bit. Specifies either Second or Minute update for the Periodic Time Update Interrupt function. If the RESET bit = 1, the interrupt function is stopped (see PERIODIC TIME UPDATE INTERRUPT FUNCTION).							
		0	Second update (Auto reset time $t_{RTN2} = 500$ ms). – Default value						
		1	Minute update (Auto reset time $t_{RTN2} = 15.6$ ms).						
4	TE	Periodic Countdown Timer Enable bit. This bit controls the start/stop setting for the Periodic Countdown Timer Interruption function (see PERIODIC COUNTDOWN TIMER INTERRUPT FUNCTION).							
		0	Stops the Periodic Countdown Timer Interrupt function. – Default value						
		1	Starts the Periodic Countdown Timer Interrupt function (a countdown starts from a preset value).						
3:2	FD	CLKOUT frequency selection. Sets the output frequency on the CLKOUT pin (see CLKOUT FREQUENCY SELECTION).							
		00	32.768 kHz – Default value						
		01	1024 Hz						
		10	1 Hz						
		11	32.768 kHz						
1:0	TD	00 to 11	Timer Clock Frequency selection. Sets the countdown source clock for the Periodic Countdown Timer Interrupt function. With this setting the Auto reset time t_{RTN1} is also defined. If RESET bit = 1, the interrupt function is stopped. See table below (see also PERIODIC COUNTDOWN TIMER INTERRUPT FUNCTION).						
TD Value	Timer Clock Frequency	Countdown period	t_{RTN1}		RESET bit				
00	4096 Hz – Default value	244.14 μ s	122 μ s		If RESET bit = 1, the interrupt function is stopped.				
01	64 Hz	15.625 ms	7.813 ms						
10	1 Hz	1 s							
11	1/60 Hz	60 s							

⁽¹⁾ This specific function accessed in Address range 00h to 0Fh is automatically updated in Address range 10h to 1Fh and vice versa.

3.7. FLAG REGISTER

0Eh, 1Eh – Flag Register

This register holds a variety of status bits. The register may be written at any time to clear any status flag.

Addresses	Function	Bit 7	Bit 6	Bit 5	Bit 4	Bit 3	Bit 2	Bit 1	Bit 0
0Eh, 1Eh ⁽¹⁾	Flag Register	○	○	UF	TF	AF	EVF	V2F	V1F
	Reset	0	0	0	0	0	X	1	1
Bit	Symbol	Value	Description						
7:6	○	0	Read only. Always 0.						
5	UF	Periodic Time Update Flag (see PERIODIC TIME UPDATE INTERRUPT FUNCTION)							
		0	It can be cleared by writing a 0 to the bit.						
		1	If set to 0 beforehand, indicates the occurrence of a Periodic Time Update Interrupt event.						
4	TF	Periodic Countdown Timer Flag (see PERIODIC COUNTDOWN TIMER INTERRUPT FUNCTION)							
		0	It can be cleared by writing a 0 to the bit.						
		1	If set to 0 beforehand, indicates the occurrence of a Periodic Countdown Timer Interrupt event.						
3	AF	Alarm Flag (see ALARM INTERRUPT FUNCTION)							
		0	It can be cleared by writing a 0 to the bit.						
		1	If set to 0 beforehand, indicates the occurrence of an Alarm Interrupt event.						
2	EVF	External Event Flag (see EXTERNAL EVENT FUNCTION)							
		X	The Reset value X depends on the voltage on the EVI pin at POR and has to be cleared by writing a 0 to the bit. Because EHL = 0 at POR, the low level is regarded as an External Event Interrupt. If X = 1, a LOW level was detected on EVI pin. If X = 0, no LOW level was detected on EVI pin.						
		0	It can be cleared by writing a 0 to the bit.						
		1	If set to 0 beforehand, indicates the occurrence of an External Event.						
1	V2F	Voltage Low Flag 2							
		0	Read: No data loss detected. Write: The V2F bit is cleared to prepare for a next low voltage detection. V1F is also cleared.						
		1	Read: Set if the voltage crosses V _{LOW2} voltage and the data in the device are no longer valid. All registers must be initialized. It can be cleared by writing a 0 to the bit. The flag is also automatically set to 1 at power on reset (POR) and has to be cleared by writing a 0 to the bit. Write: The V2F bit remains unchanged.						
0	V1F	Voltage Low Flag 1							
		0	Read: Temperature compensation is effective. ⁽²⁾ Write: The V1F bit is cleared to prepare for a next low voltage detection. V2F is also cleared.						
		1	Read: Set if the voltage crosses V _{LOW1} voltage and the temperature compensation is stopped. It can be cleared by writing a 0 to the bit. The flag is also automatically set to 1 at power on reset (POR) and has to be cleared by writing a 0 to the bit. Write: The V1F bit remains unchanged.						

⁽²⁾ Note that between V_{LOW1} (1.2 V) and V_{DD MIN} (1.5 V), time accuracy specification limits are not guaranteed.

⁽¹⁾ This specific function accessed in Address range 00h to 0Fh is automatically updated in Address range 10h to 1Fh and vice versa.

3.8. CONTROL REGISTER

0Fh, 1Fh – Control Register

This register is used to control the interrupt event output from the $\overline{\text{INT}}$ pin and the stop/start status of clock and calendar operations.

Addresses	Function	Bit 7	Bit 6	Bit 5	Bit 4	Bit 3	Bit 2	Bit 1	Bit 0
0Fh, 1Fh ⁽¹⁾	Control Register	RESERVED		UIE	TIE	AIE	EIE	○	RESET
	Reset	0	0	0	0	0	0	0	0
Bit	Symbol	Value	Description						
7:6	RESERVED	0	Unused, but has to be 0 to avoid extraneous leakage.						
5	UIE	Periodic Time Update Interrupt Enable (see PERIODIC TIME UPDATE INTERRUPT FUNCTION)							
		0	No interrupt signal is generated on $\overline{\text{INT}}$ pin and UF flag is not set when a Periodic Time Update event occurs or the signal is cancelled on $\overline{\text{INT}}$ pin. – Default value						
1	An interrupt signal is generated on $\overline{\text{INT}}$ pin and the UF flag is set when a Periodic Time Update event occurs. The low-level output signal is automatically cleared after $t_{\text{RTN2}} = 500 \text{ ms}$ (Second update) or $t_{\text{RTN2}} = 15.6 \text{ ms}$ (Minute update).								
4	TIE	Periodic Countdown Timer Interrupt Enable (see PERIODIC COUNTDOWN TIMER INTERRUPT FUNCTION)							
		0	No interrupt signal is generated on $\overline{\text{INT}}$ pin when a Periodic Countdown Timer event occurs or the signal is cancelled on $\overline{\text{INT}}$ pin. – Default value						
1	An interrupt signal is generated on $\overline{\text{INT}}$ pin when a Periodic Countdown Timer event occurs. The low-level output signal is automatically cleared after $t_{\text{RTN1}} = 122 \mu\text{s}$ (TD = 00) or $t_{\text{RTN1}} = 7.813 \text{ ms}$ (TD = 01, 10, 11).								
3	AIE	Alarm Interrupt Enable (see ALARM INTERRUPT FUNCTION)							
		0	No interrupt signal is generated on $\overline{\text{INT}}$ pin when an Alarm event occurs or the signal is cancelled on $\overline{\text{INT}}$ pin. – Default value						
1	An interrupt signal is generated on $\overline{\text{INT}}$ pin when an Alarm event occurs. This setting is retained until the AF bit value is cleared to 0 (no automatic cancellation).								
2	EIE	External Event Interrupt Enable (see EXTERNAL EVENT FUNCTION)							
		0	No interrupt signal is generated on $\overline{\text{INT}}$ pin when an External Event on EVI pin occurs. – Default value						
1	An interrupt signal is generated on $\overline{\text{INT}}$ pin when an External Event on EVI pin occurs. This setting is retained until the EVF bit value is cleared to 0 (no automatic cancellation).								
1	○	0	Read only. Always 0.						
0	RESET	Reset/Stop. This bit is used for a software-based time adjustment (synchronizing) (see RESET BIT FUNCTION).							
		0	No reset. – Default value						
1	Resets the divider chain. Values less than seconds of the counter in the clock and calendar circuitry are reset to 0 (2 Hz to 4 kHz), and the 1 Hz clock stops. The 100 th Seconds register is also reset to 00. The Periodic Countdown Timer, Periodic Time Update and Alarm Interrupts do not occur. The External Event Interrupt function is still working but cannot provide useful data.								

⁽¹⁾ This specific function accessed in Address range 00h to 0Fh is automatically updated in Address range 10h to 1Fh and vice versa.

3.9. OFFSET REGISTER

2Ch – Offset Register

This register holds the OFFSET value for the aging correction.

Address	Function	Bit 7	Bit 6	Bit 5	Bit 4	Bit 3	Bit 2	Bit 1	Bit 0
2Ch	Offset	○	○	OFFSET					
	Reset	0	0	0	0	0	0	0	0
Bit	Symbol	Value	Description						
7:6	○	0	Read only. Always 0.						
5:0	OFFSET	-32 to +31	The amount of the effective frequency offset. This is a two's complement number with a range of -32 to +31 adjustment steps (maximum correction range is roughly ±7.4 ppm). The correction value of one LSB corresponds to $1/(32768*128) = 0.2384$ ppm (see AGING CORRECTION).						
OFFSET	Unsigned value	Two's complement	Offset value in ppm ^(*)						
011111	31	31	7.391						
011110	30	30	7.153						
:	:	:	:						
000001	1	1	0.238						
000000 (default)	0	0	0.000						
111111	63	-1	-0.238						
111110	62	-2	-0.477						
:	:	:	:						
100001	33	-31	-7.391						
100000	32	-32	-7.629						

(*) Calculated with 5 decimal places ($1/(32768*128) = 0.23842$ ppm)

3.10. CAPTURE BUFFER/EVENT CONTROL REGISTERS

20h – 100th Seconds CP (Read Only)

This register holds a captured (copied) value of the 100th Seconds register (Time Stamp), in two binary coded decimal (BCD) digits. The values are from 00 to 99.

Address	Function	Bit 7	Bit 6	Bit 5	Bit 4	Bit 3	Bit 2	Bit 1	Bit 0
20h	100 th Seconds CP (Read Only)	80	40	20	10	8	4	2	1
	Reset	0	0	0	0	0	0	0	0
Bit	Symbol	Value	Description						
7:0	100 th Seconds CP (Read Only)	00 to 99	Holds a captured value of the 100 th Seconds register, coded in BCD format. The 100 th Seconds CP register is cleared to 00 when the ERST bit is 1 in case of an External Event detection on EVI pin.						

21h - Seconds CP (Read Only)

This register holds a captured (copied) value of the Seconds register (Time Stamp), in two binary coded decimal (BCD) digits. The values are from 00 to 59.

Address	Function	Bit 7	Bit 6	Bit 5	Bit 4	Bit 3	Bit 2	Bit 1	Bit 0
21h	Seconds CP (Read Only)	0	40	20	10	8	4	2	1
	Reset	0	0	0	0	0	0	0	0
Bit	Symbol	Value	Description						
7	0	0	Read only. Always 0.						
6:0	Seconds CP (Read Only)	00 to 59	Holds a captured value of the Seconds register, coded in BCD format. The Seconds CP register is cleared to 00 when the ERST bit is 1 in case of an External Event detection on EVI pin.						

2Fh – Event Control

This register controls the event detection on the EVI pin. Depending of the EHL bit a high or a low signal can be detected. Moreover a digital glitch filtering can be applied to the EVI signal by selecting a sampling period in the ET field.

Address	Function	Bit 7	Bit 6	Bit 5	Bit 4	Bit 3	Bit 2	Bit 1	Bit 0
2Fh	Event Control	ECP	EHL	ET		○	○	○	ERST
	Reset	0	0	0	0	0	0	0	0
Bit	Symbol	Value	Description						
7	ECP	Event Capture Enable (Time Stamp Enable) (see EXTERNAL EVENT FUNCTION)							
		0	Disables the Event Capture. – Default value						
		1	An External Event detected on pin EVI will cause a capture of the Seconds and the 100 th Seconds, i.e. they are copied into the Seconds CP and 100 th Seconds CP registers.						
6	EHL	Event High/Low detection Select (see EXTERNAL EVENT FUNCTION)							
		0	The Low level (negative edge) is regarded as the External Event Interrupt on pin EVI. – Default value						
		1	The High level (positive edge) is regarded as the External Event Interrupt on pin EVI.						
5:4	ET	Event Filtering Time set. Applies a digital filtering to the EVI pin by sampling the EVI signal. Edge and stable steady state detection when ET = 01, 10 or 11 (see USE OF THE EXTERNAL EVENT FUNCTION).							
		00	No filtering. Edge detection (minimal pulse time is 30.5 μs). – Default value						
		01	3.9 ms sampling period (256 Hz).						
		10	15.6 ms sampling period (64 Hz).						
		11	125 ms sampling period (8 Hz).						
3:1	○	0	Read only. Always 0.						
0	ERST	Event Reset. This bit is used for a hardware-based time adjustment (synchronizing) (see ERST BIT FUNCTION)							
		0	No reset if an External Event is detected. – Default value						
		1	In case of an External Event detection at the EVI pin the 100 th Seconds Register is reset to 0. Moreover, the 100 th Seconds CP and Seconds CP registers are also reset to 0, whatever the ECP value is. After the event detection, the ERST bit is reset to 0 automatically. When 1, the reset function may be cancelled when the ERST bit is set back to 0 before an event occurs.						

3.11. REGISTER RESET VALUES SUMMARY

Address	Function	Bit 7	Bit 6	Bit 5	Bit 4	Bit 3	Bit 2	Bit 1	Bit 0
10h	100 th Seconds (Read Only)	X	X	X	X	X	X	X	X
00h, 11h ⁽¹⁾	Seconds	○	X	X	X	X	X	X	X
01h, 12h ⁽¹⁾	Minutes	○	X	X	X	X	X	X	X
02h, 13h ⁽¹⁾	Hours	○	○	X	X	X	X	X	X
03h, 14h ⁽¹⁾	Weekday	○	X	X	X	X	X	X	X
04h, 15h ⁽¹⁾	Date	○	○	X	X	X	X	X	X
05h, 16h ⁽¹⁾	Month	○	○	○	X	X	X	X	X
06h, 17h ⁽¹⁾	Year	X	X	X	X	X	X	X	X
07h	RAM	0	0	0	0	0	0	0	0
08h, 18h ⁽¹⁾	Minutes Alarm	0	0	0	0	0	0	0	0
09h, 19h ⁽¹⁾	Hours Alarm	0	0	0	0	0	0	0	0
0Ah, 1Ah ⁽¹⁾	Weekday Alarm / Date Alarm	0	0	0	0	0	0	0	0
0Bh, 1Bh ⁽¹⁾	Timer Counter 0	0	0	0	0	0	0	0	0
0Ch, 1Ch ⁽¹⁾	Timer Counter 1	0	0	0	0	0	0	0	0
0Dh, 1Dh ⁽¹⁾	Extension Register	0	0	0	0	0	0	0	0
0Eh, 1Eh ⁽¹⁾	Flag Register	○	○	0	0	0	X	1	1
0Fh, 1Fh ⁽¹⁾	Control Register	0	0	0	0	0	0	○	0
20h	100 th Seconds CP (Read Only)	0	0	0	0	0	0	0	0
21h	Seconds CP (Read Only)	○	0	0	0	0	0	0	0
2Ch	Offset	○	○	0	0	0	0	0	0
2Fh	Event Control	0	0	0	0	○	○	○	0

○ Read only. Always 0. X means undefined.

⁽¹⁾ This specific function accessed in Address range 00h to 0Fh is automatically updated in Address range 10h to 1Fh and vice versa.

RV-8803-C7 reset values after power on:

Time (hh:mm:ss.00)	=	XX:XX:XX.XX
Date (YY-MM-DD)	=	XX-XX-XX
Weekday	=	X
Time CP (ss.00)	=	00.00 (read only)
TEST Bit	=	0 (should always be written with logic 0)
EVF Flag	=	0 or 1 (0 if High level detected on EVI pin; 1 if Low level detected on EVI pin)
Pins	=	CLKOUT Frequency = 32.768 kHz (when CLKOE is HIGH)
Offset	=	0
Alarm function	=	enabled, once per weekday alarm selected
Timer function	=	disabled, Timer Clock Frequency = 4096 Hz
Update function	=	Second update is selected
Ext. Event function	=	Capture disabled, LOW level is regarded as External Event on pin EVI, no filtering on EVI pin, no reset if an External Event is detected
Reset function	=	disabled
Interrupts	=	disabled
Voltage Low Flags	=	1 (they can be cleared by writing 0 to one of the bits)

4. DETAILED FUNCTIONAL DESCRIPTION

4.1. POWER ON RESET (POR)

The power on reset (POR) is generated at start-up (see POWER ON AC ELECTRICAL CHARACTERISTICS). All registers including the Counter Registers are initialized to their reset values (see REGISTER RESET VALUES SUMMARY).

4.2. POWER MANAGEMENT

The circuit is always on and each temperature sensing interval, i.e. every second, is temperature compensated. The digital part is always on, but some functions are clock gated (like I²C). By default, at power up, the circuit will always go to the lower power consumption mode (power-off). Detecting an activity on the I²C will wake-up the digital part of the circuit. To achieve the specified time keeping current consumption, extra features like CLKOUT and I²C interface need to be inactive.

4.3. CLOCK SOURCE

The built-in 32.768 kHz crystal is the clock source for the digital part. After thermal compensation, the RV-8803-C7 provides a very accurate time with temperature compensation for an outstanding low current consumption.

4.4. INTERRUPT OUTPUT

The interrupt pin \overline{INT} can be triggered by four different functions:

- PERIODIC COUNTDOWN TIMER INTERRUPT FUNCTION
- PERIODIC TIME UPDATE INTERRUPT FUNCTION
- ALARM INTERRUPT FUNCTION
- EXTERNAL EVENT FUNCTION

Interrupt scheme:

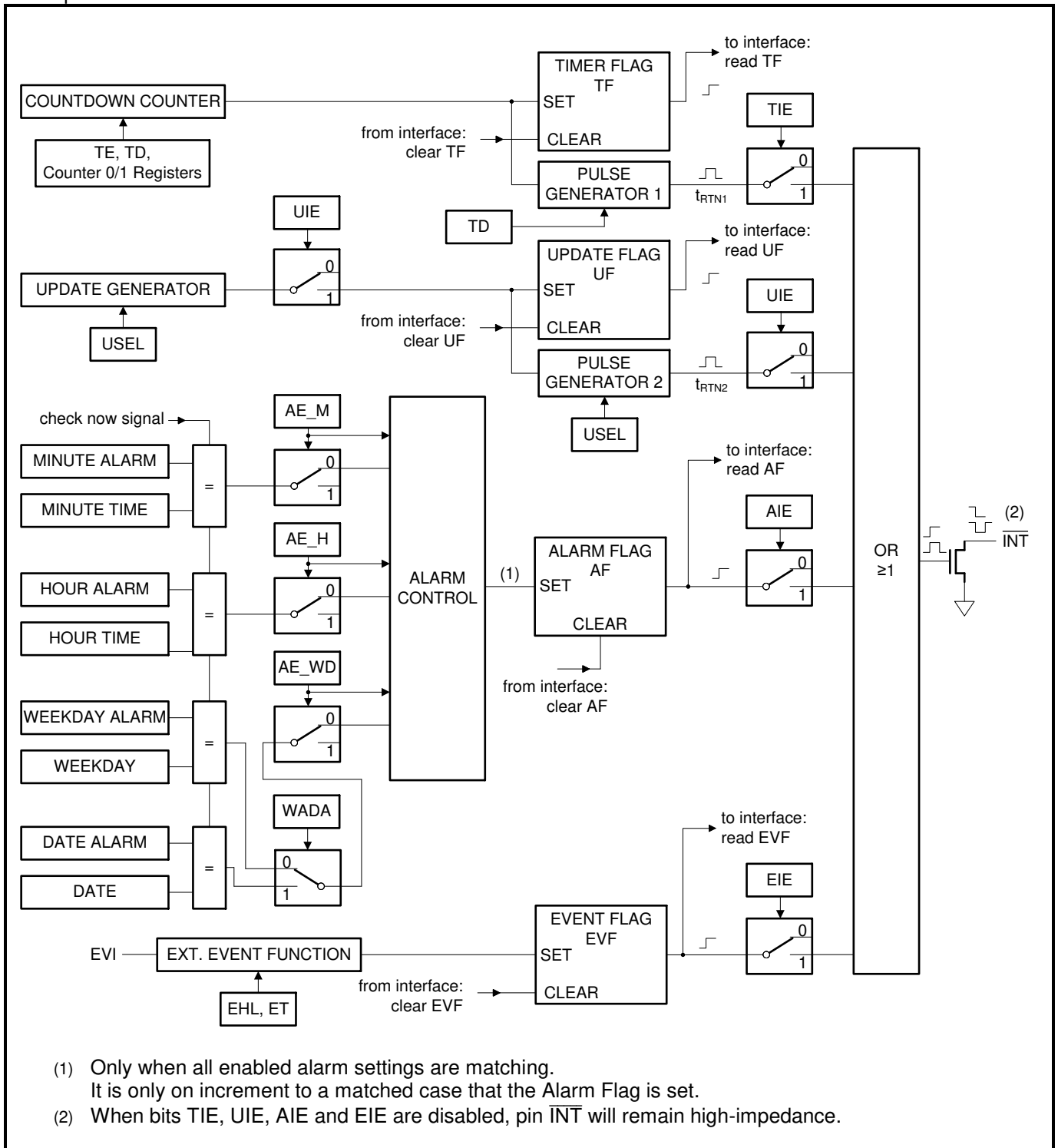

4.4.1.SERVICING INTERRUPTS

The $\overline{\text{INT}}$ pin can indicate four types of interrupts. It outputs the logic OR operation result of these interrupt outputs. When an interrupt is detected (when $\overline{\text{INT}}$ pin produces a negative pulse or is at low level), the TF, UF, AF and EVF flags can be read to determine which interrupt event has occurred.

To keep $\overline{\text{INT}}$ pin from changing to low level, clear the TIE, UIE, AIE and EIE bits. To check whether an event has occurred without outputting any interrupts via the $\overline{\text{INT}}$ pin, software can read the TF, AF and EVF interrupt flags (polling).

Exception: The UF flag is only set to 1 by the periodic time update interrupt function when the UIE bit is set to 1.

4.5. PERIODIC COUNTDOWN TIMER INTERRUPT FUNCTION

The Periodic Countdown Timer Interrupt function generates an interrupt event periodically at any period set from 244.14 μs to 4095 minutes.

When an interrupt event is generated, the $\overline{\text{INT}}$ pin goes to the low level and the TF flag is set to 1 to indicate that an event has occurred. The output on the $\overline{\text{INT}}$ pin is only effective if the TIE bit in the Control Register is set to 1. The low-level output signal on the $\overline{\text{INT}}$ pin is automatically cleared after the Auto reset time t_{RTN1} . $t_{\text{RTN1}} = 122 \mu\text{s}$ (TD = 00) or $t_{\text{RTN1}} = 7.813 \text{ ms}$ (TD = 01, 10, 11).

4.5.1. PERIODIC COUNTDOWN TIMER DIAGRAM

Diagram of the Periodic Countdown Timer Interrupt function:

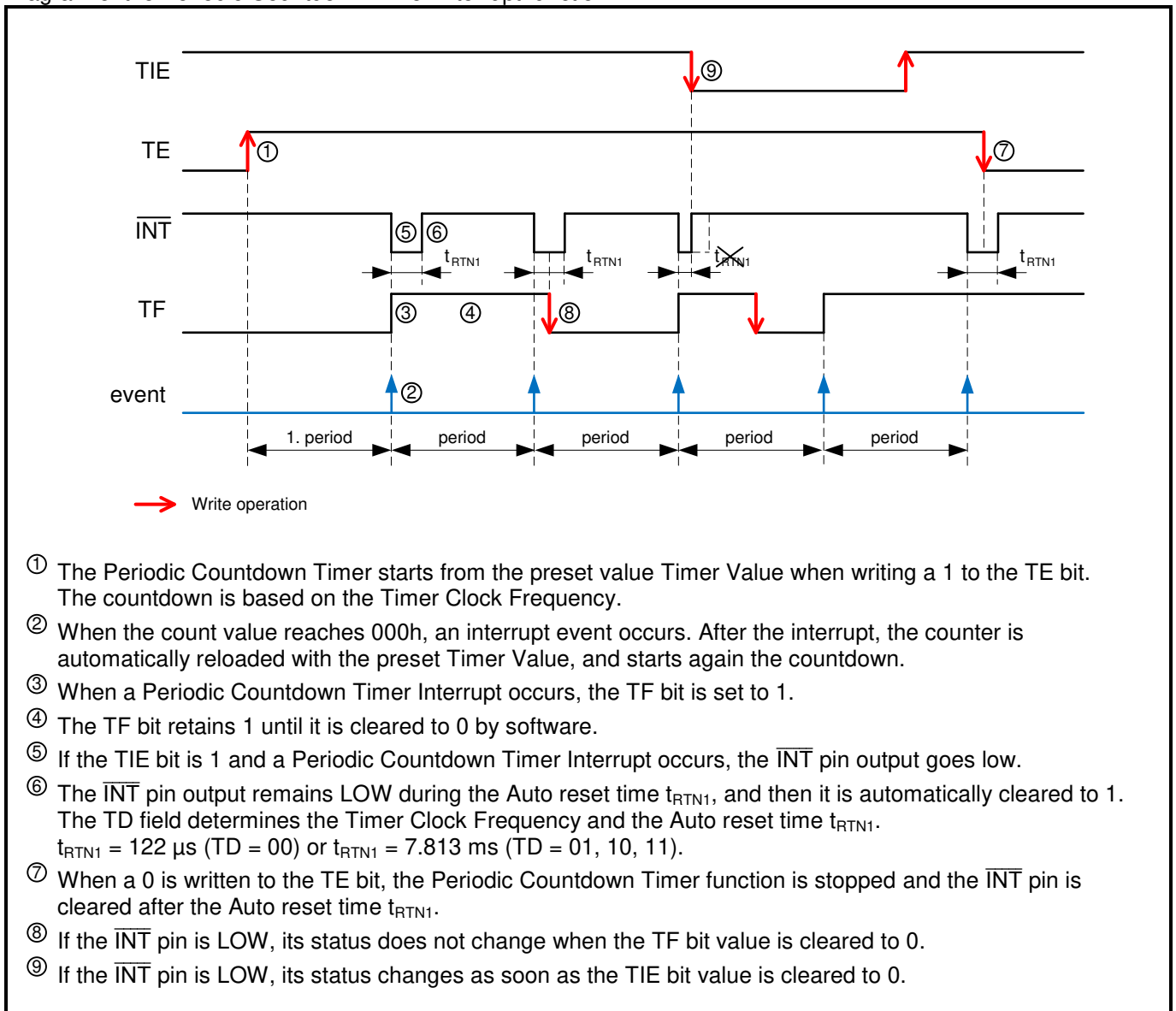

4.5.2.USE OF THE PERIODIC COUNTDOWN TIMER

The following registers, fields and bits are related to the Periodic Countdown Timer Interrupt function:

- Timer Counter 0 Register (0Bh, 1Bh) (see PERIODIC COUNTDOWN TIMER CONTROL REGISTERS)
- Timer Counter 1 Register (0Ch, 1Ch) (see PERIODIC COUNTDOWN TIMER CONTROL REGISTERS)
- TE bit and TD field (see EXTENSION REGISTER, 0Dh, 1Dh)
- TF bit (see FLAG REGISTER, 0Eh, 1Eh)
- TIE bit (see CONTROL REGISTER, 0Fh, 1Fh)

Prior to entering any timer settings for the Periodic Countdown Timer Interrupt, it is recommended to write a 0 to the TIE and TE bits to prevent inadvertent interrupts on $\overline{\text{INT}}$ pin. When the RESET bit value is 1, the Periodic Countdown Timer Interrupt function event does not occur. When the Periodic Countdown Timer Interrupt function is not used, the 2 Bytes of the Timer Counter registers (0Bh, 1Bh and 0Ch, 1Ch) can be used as RAM bytes. The Timer Clock Frequency selection field TD is used to set the countdown period (source clock) for the Periodic Countdown Timer Interrupt function (four settings are possible).

Procedure to use the Periodic Countdown Timer Interrupt function:

1. Initialize bits TE, TIE and TF to 0. In that order, to prevent inadvertent interrupts on $\overline{\text{INT}}$ pin.
2. Choose the Timer Clock Frequency and write the corresponding value in the TD field.
3. Choose the Countdown Period based on the Timer Clock Frequency, and write the corresponding Timer Value to the registers Timer Counter 0 (0Bh, 1Bh) and Timer Counter 1 (0Ch, 1Ch). See following table.
4. Set the TIE bit to 1 if you want to get a hardware interrupt on $\overline{\text{INT}}$ pin.
5. Set the TE bit from 0 to 1 to start the Periodic Countdown Timer. The countdown starts at the rising edge of the SCL signal after Bit 0 of the Address D is transferred. See subsequent Figure that shows the start timing.

Countdown Period in seconds:

$$\text{Countdown Period} = \frac{\text{Timer Value}}{\text{Timer Clock Frequency}}$$

Countdown Period:

Timer Value (0Bh, 1Bh), (0Ch, 1Ch)	Countdown Period			
	TD = 00 (4096 Hz)	TD = 01 (64 Hz)	TD = 10 (1 Hz)	TD = 11 (1/60 Hz)
0	-	-	-	-
1	244.14 μ s	15.625 ms	1 s	1 min
2	488.28 μ s	31.25 ms	2 s	2 min
:	:	:	:	:
41	10.010 ms	640.63 ms	41 s	41 min
205	50.049 ms	3.203 s	205 s	205 min
410	100.10 ms	6.406 s	410 s	410 min
2048	500.00 ms	32.000 s	2048 s	2048 min
:	:	:	:	:
4095 (FFFh)	0.9998 s	63.984 s	4095 s	4095 min

Start timing of the Periodic Countdown Timer:

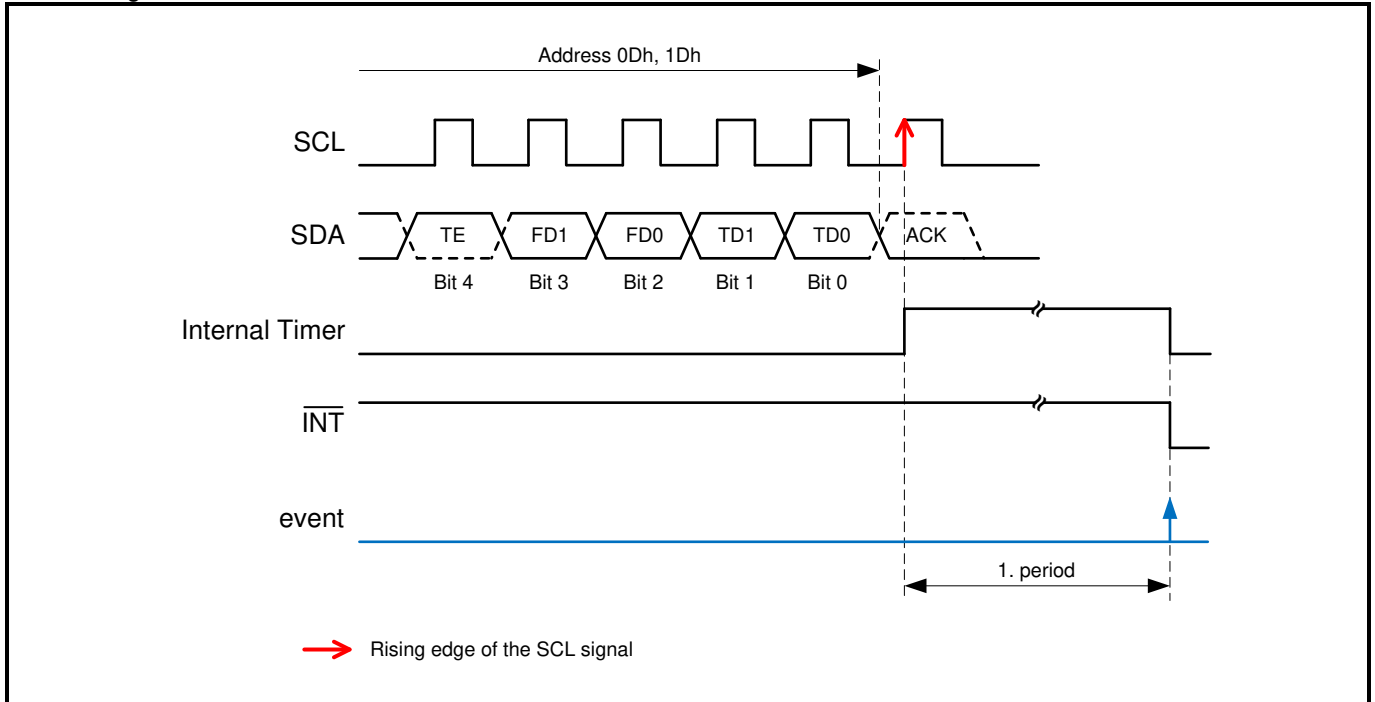

4.5.3.FIRST PERIOD DURATION

When the TF flag is set, an interrupt signal on \overline{INT} is generated if this mode is enabled. See Section INTERRUPT OUTPUT for details on how the interrupt can be controlled.

When starting the timer for the first time, the first period has an uncertainty. The uncertainty is a result of the enable instruction being generated from the interface clock which is asynchronous from the Timer Clock Frequency. Subsequent timer periods do not have such deviation. The amount of deviation for the first timer period depends on the chosen Timer Clock Frequency, see following Table.

First period duration for Timer Value $n^{(1)}$:

TD	Timer Clock Frequency	First period duration		Subsequent periods duration
		Minimum Period	Maximum Period	
00	4096 Hz	$n * 244 \mu s + 61 \mu s$	$(n + 1) * 244 \mu s + 61 \mu s$	$n * 244 \mu s$
01	64 Hz	$n * 15.625 ms$	$(n + 1) * 15.625 ms$	$n * 15.625 ms$
10	1 Hz	$n * 1 s$	$(n + 1) * 1 s$	$n * 1 s$
11	1/60 Hz	$n * 60 s$	$(n + 1) * 60 s$	$n * 60 s$

⁽¹⁾ Timer Values n from 1 to 4095 are valid. Loading the counter with 0 stops the timer.

At the end of every countdown, the timer sets the Periodic Countdown Timer Flag (bit TF in Flag Register). Bit TF can only be cleared by command. The asserted bit TF can be used to generate an interrupt at pin \overline{INT} .

When reading the Timer Value, the preset value is returned and not the actual value.

4.6. PERIODIC TIME UPDATE INTERRUPT FUNCTION

The Periodic Time Update Interrupt function generates an interrupt event periodically at the One-Second or the One-Minute update time, according to the selected timer source with bit USEL.

When an interrupt event is generated, the $\overline{\text{INT}}$ pin goes to the low level and the UF flag is set to 1 to indicate that an event has occurred. The output on the $\overline{\text{INT}}$ pin is only effective if the UIE bit in the Control Register is set to 1. The low-level output signal on the $\overline{\text{INT}}$ pin is automatically cleared after the Auto reset time t_{RTN2} . $t_{\text{RTN2}} = 500 \text{ ms}$ (Second update) or $t_{\text{RTN2}} = 15.6 \text{ ms}$ (Minute update).

4.6.1. PERIODIC TIME UPDATE DIAGRAM

Diagram of the Periodic Time Update Interrupt function:

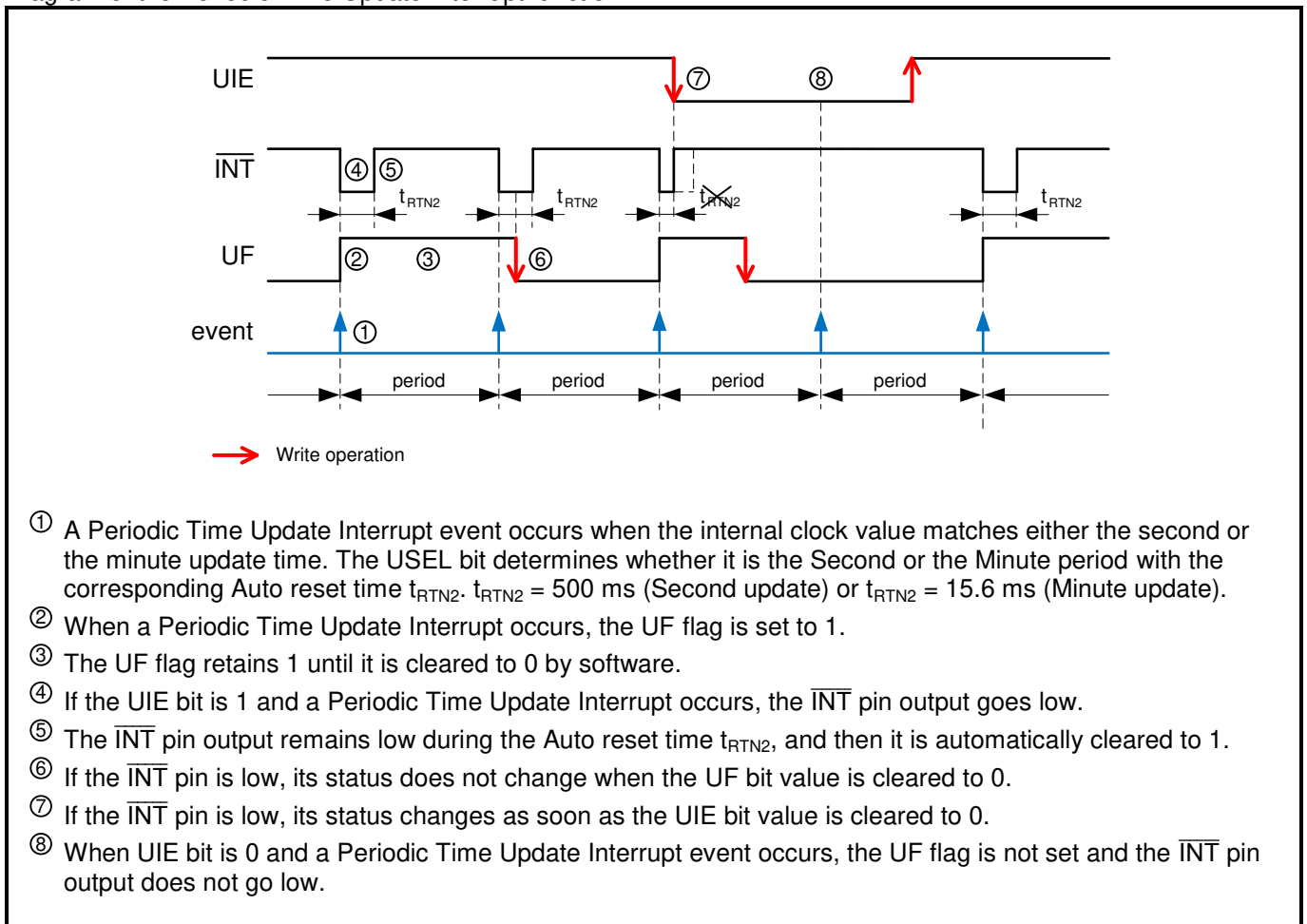

- ① A Periodic Time Update Interrupt event occurs when the internal clock value matches either the second or the minute update time. The USEL bit determines whether it is the Second or the Minute period with the corresponding Auto reset time t_{RTN2} . $t_{\text{RTN2}} = 500 \text{ ms}$ (Second update) or $t_{\text{RTN2}} = 15.6 \text{ ms}$ (Minute update).
- ② When a Periodic Time Update Interrupt occurs, the UF flag is set to 1.
- ③ The UF flag retains 1 until it is cleared to 0 by software.
- ④ If the UIE bit is 1 and a Periodic Time Update Interrupt occurs, the $\overline{\text{INT}}$ pin output goes low.
- ⑤ The $\overline{\text{INT}}$ pin output remains low during the Auto reset time t_{RTN2} , and then it is automatically cleared to 1.
- ⑥ If the $\overline{\text{INT}}$ pin is low, its status does not change when the UF bit value is cleared to 0.
- ⑦ If the $\overline{\text{INT}}$ pin is low, its status changes as soon as the UIE bit value is cleared to 0.
- ⑧ When UIE bit is 0 and a Periodic Time Update Interrupt event occurs, the UF flag is not set and the $\overline{\text{INT}}$ pin output does not go low.

4.6.2.USE OF THE PERIODIC TIME UPDATE INTERRUPT

The following bits are related to the Periodic Time Update Interrupt function:

- USEL bit (see EXTENSION REGISTER, 0Dh, 1Dh)
- UF bit (see FLAG REGISTER, 0Eh, 1Eh)
- UIE bit (see CONTROL REGISTER, 0Fh, 1Fh)

Prior to entering any other settings, it is recommended to write a 0 to the UIE bit to prevent inadvertent interrupts on $\overline{\text{INT}}$ pin. If the RESET bit is set to 1 (see CONTROL REGISTER, 0Fh, 1Fh) the divider chain is reset and the Periodic Time Update Interrupt does not occur. The reset function only interrupts the Periodic Time Update Interrupt function but does not turn it off.

Procedure to use the Periodic Time Update Interrupt function:

1. Initialize bits UIE and UF to 0.
2. Choose the timer source clock and write the corresponding value in the USEL bit.
3. Set the UIE bit to 1 to enable the Periodic Time Update Interrupt function with hardware interrupt on $\overline{\text{INT}}$ pin.
4. The first interrupt will occur after the next event, either second or minute change.

4.7. ALARM INTERRUPT FUNCTION

The Alarm Interrupt function generates an interrupt for alarm settings such as date, weekday, hour or minute settings.

When an interrupt event is generated, the $\overline{\text{INT}}$ pin goes to the low level and the AF flag is set to 1 to indicate that an event has occurred.

4.7.1. ALARM DIAGRAM

Diagram of the Alarm Interrupt function:

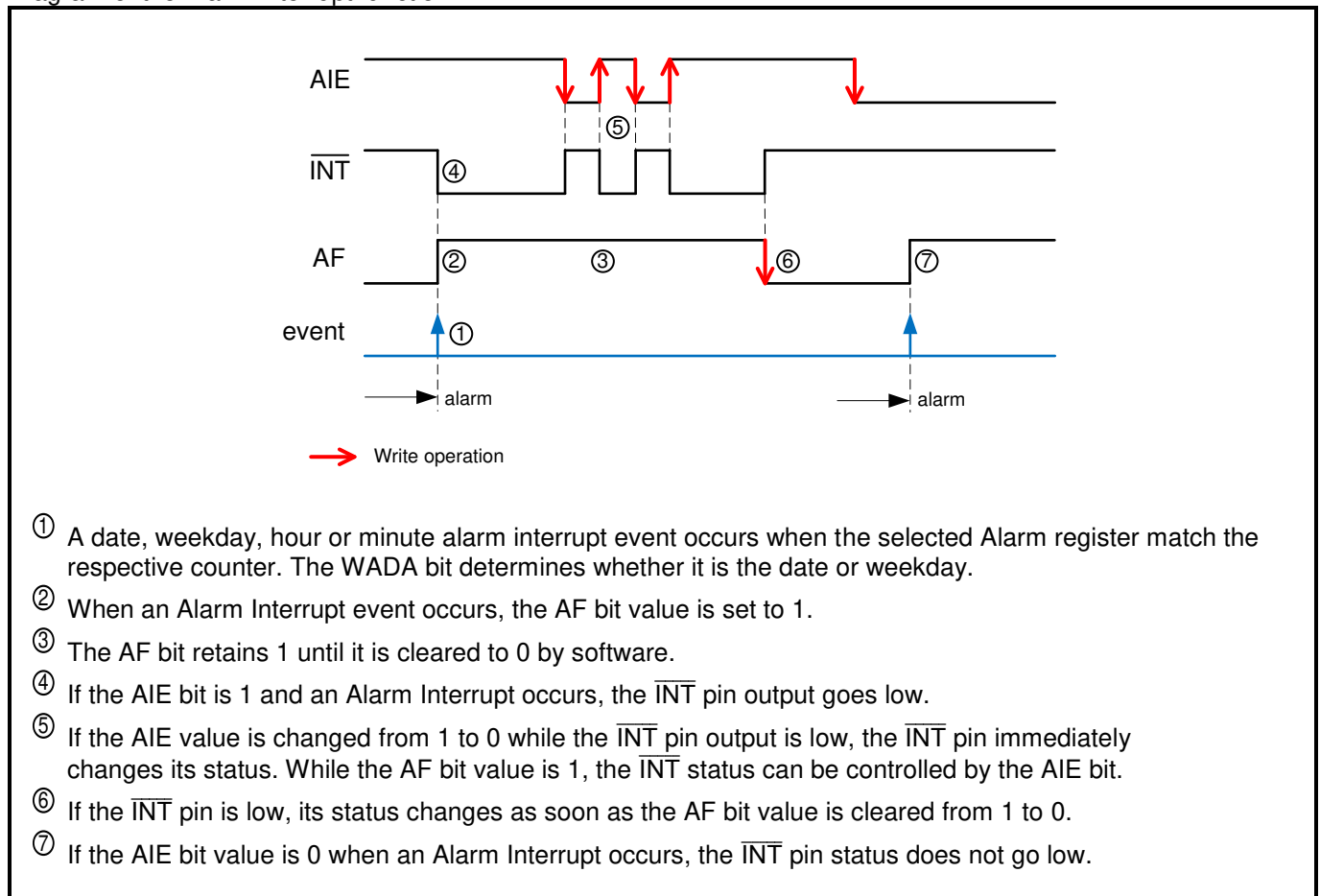

4.7.2.USE OF THE ALARM INTERRUPT

The following registers and bits are related to the Alarm Interrupt function:

- Minutes Register (01h, 12h) (see CLOCK REGISTERS)
- Hours Register (02h, 13h) (see CLOCK REGISTERS)
- Weekday Register (03h, 14h) (see CALENDAR REGISTERS)
- Date Register (04h, 15h) (see CALENDAR REGISTERS)
- Minutes Alarm Register and AE_M bit (08h, 18h) (see ALARM REGISTERS)
- Hours Alarm Register and AE_H bit (09h, 19h) (see ALARM REGISTERS)
- Weekday/Date Alarm Register and AE_WD bit (0Ah, 1Ah) (see ALARM REGISTERS)
- WADA bit (see EXTENSION REGISTER, 0Dh, 1Dh)
- AF bit (see FLAG REGISTER, 0Eh, 1Eh)
- AIE bit (see CONTROL REGISTER, 0Fh, 1Fh)

Prior to entering any timer settings for the Alarm Interrupt, it is recommended to write a 0 to the AIE bit to prevent inadvertent interrupts on $\overline{\text{INT}}$ pin. When the RESET bit value is 1, the Alarm Interrupt function event does not occur. When the Alarm Interrupt function is not used, the 3 Bytes of the Alarm registers (08h, 18h; 09h, 19h and 0Ah, 1Ah) can be used as RAM bytes. In such case, be sure to write a 0 to the AIE bit (if the AIE bit value is 1 and the Alarm registers are used as RAM registers, $\overline{\text{INT}}$ may change to low level unintentionally).

Procedure to use the Alarm Interrupt function:

1. Initialize bits AIE and AF to 0.
2. Choose weekday alarm or date alarm (weekday/date) by setting the WADA bit. WADA = 0 for weekday alarm or WADA = 1 for date alarm.
3. Write the desired alarm settings in registers 08h, 18h to 0Ah, 1Ah. The three alarm enable bits, AE_M, AE_H and AE_WD, are used to select the corresponding register that has to be taken into account for match or not. See the following table.
4. Set the AIE bit to 1 if you want to get a hardware interrupt on $\overline{\text{INT}}$ pin.

Alarm Interrupt:

Alarm enable bits			Alarm event
AE_WD	AE_H	AE_M	
0	0	0	When minutes, hours and weekday/date match (once per weekday/date) ⁽¹⁾ – Default value
0	0	1	When hours and weekday/date match (once per weekday/date) ⁽¹⁾
0	1	0	When minutes and weekday/date match (once per hour per weekday/date) ⁽¹⁾
0	1	1	When weekday/date match (once per weekday/date) ⁽¹⁾
1	0	0	When hours and minutes match (once per day) ⁽¹⁾
1	0	1	When hours match (once per day) ⁽¹⁾
1	1	0	When minutes match (once per hour) ⁽¹⁾
1	1	1	Every minute ⁽²⁾

⁽¹⁾ AE_x bits (where x is M, H and WD)
 AE_x = 0: Alarm is enabled
 AE_x = 1: Alarm is disabled

⁽²⁾ If all AE_x = 1: Alarm event every minute

4.8. EXTERNAL EVENT FUNCTION

The External Event Interrupt and Time Stamp function is enabled by the control bits EIE and ECP. Depending of the EHL bit a high level (positive edge) or low level (negative edge) signal can be regarded as an event and furthermore a digital glitch filtering is applied to the EVI signal when selecting a sampling period in the ET field. If enabled (EIE and ECP set to 1 and EVF flag was cleared to 0 before) and an External Event on EVI pin is detected, the seconds and 100th seconds are captured and copied into the Seconds CP and 100th Seconds CP registers, the \overline{INT} is issued and the EVF flag is set to 1 to indicate that an external event has occurred.

External Event detection and Time Stamp function:

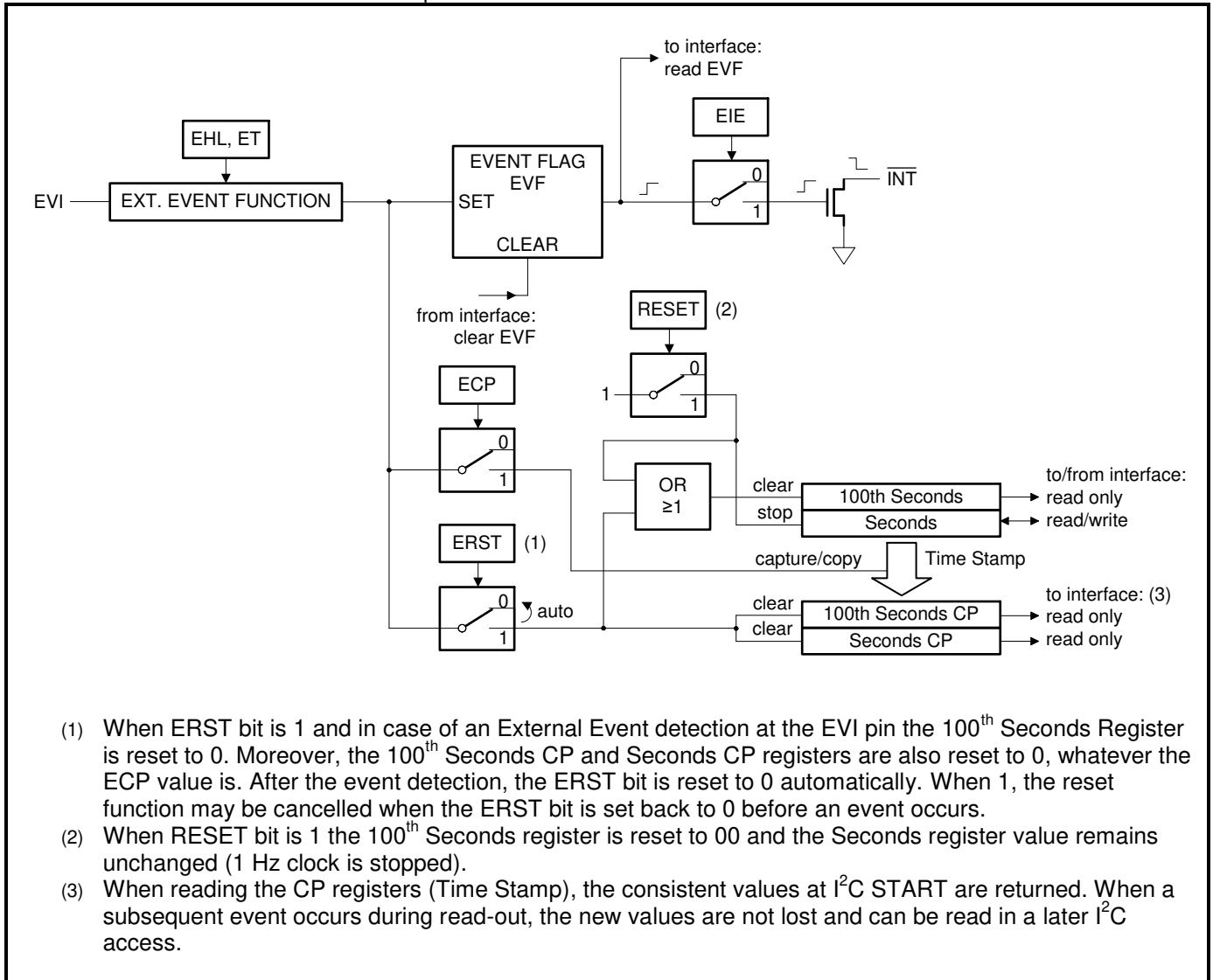

4.8.1.EXTERNAL EVENT DIAGRAM

Diagram of the External Event function.

Example with positive edge/level detection (EHL = 1) and without event reset function (ERST = 0):

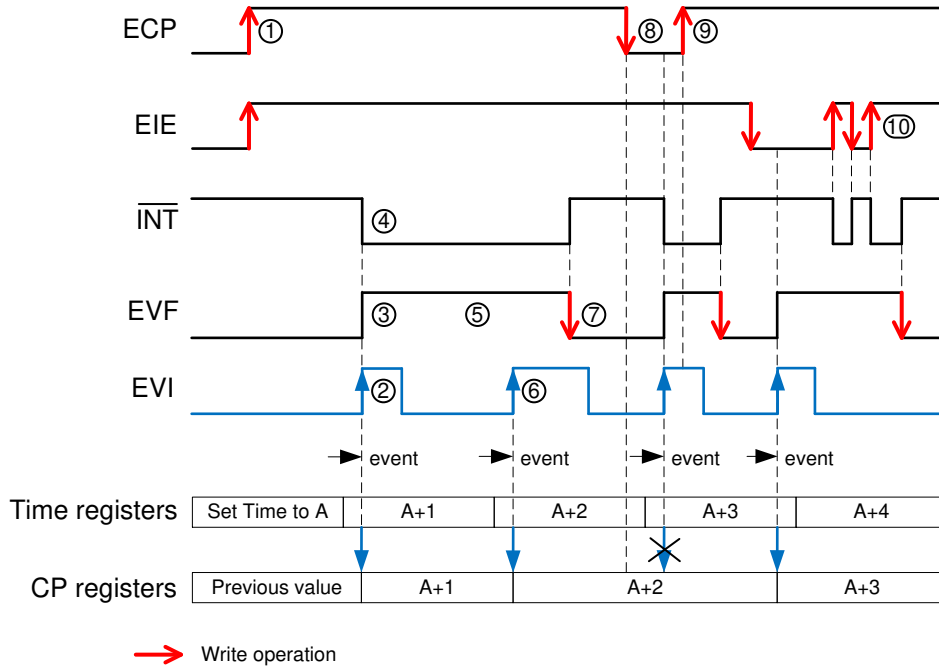

- ① Initialize time and date and set ECP bit to 1 if Time Stamp is needed and EIE bit to 1 if interrupt on $\overline{\text{INT}}$ pin is required. The EVF flag needs to be cleared to reset the $\overline{\text{INT}}$ pin and to prepare the system for an event. In this example, EHL is set to 1 for positive edge detection.
- ② An External Event on EVI pin is detected. Pay attention to the debounce time when using the filtering (ET field). The value (A+1) is captured/copied into the CP registers.
- ③ When an External Event Interrupt occurs, the EVF flag is set to 1.
- ④ If the EIE bit is 1 and an External Event Interrupt occurs, the $\overline{\text{INT}}$ pin output goes low.
- ⑤ The EVF flag retains 1 until it is cleared to 0 by software.
- ⑥ No interrupt occurs on $\overline{\text{INT}}$ pin because the EVF flag was not set back to 0. But, new value (A+2) is captured in the CP registers.
- ⑦ If the $\overline{\text{INT}}$ pin is low, its status changes as soon as the EVF flag is cleared to 0, even if EVI input is high level.
- ⑧ If ECP is set to 0, no capture occurs.
- ⑨ If the EVI input is 1 (steady state) and the ECP bit is set from 0 to 1, no capture is done.
- ⑩ While the EVF bit value is 1, the $\overline{\text{INT}}$ status can be controlled by the EIE bit.

4.8.2.USE OF THE EXTERNAL EVENT FUNCTION

The following registers and bits are related to the External Event Interrupt and Time Stamp function:

- 100th Seconds Register (10h) (see CLOCK REGISTERS)
- Seconds Register (00h, 11h) (see CLOCK REGISTERS)
- 100th Seconds CP Register (20h) (see CLOCK REGISTERS)
- Seconds CP Register (21h) (see CLOCK REGISTERS)
- ECP bit, EHL bit, ET field and ERST bit (see CAPTURE BUFFER/EVENT CONTROL REGISTERS, 2Fh)
- EVF bit (see FLAG REGISTER, 0Eh, 1Eh)
- EIE bit (see CONTROL REGISTER, 0Fh, 1Fh)

Prior to entering any timer settings for the event interrupt, it is recommended to write a 0 to the EIE bit to prevent inadvertent interrupts on $\overline{\text{INT}}$ pin.

Procedure to use the External Event Interrupt and Time Stamp function:

1. Initialize bits EIE and EVF to 0.
2. Set the ECP bit to 1 if you want to capture the seconds and 100th seconds.
3. Set the EHL bit to 1 or 0 to choose high or low level detection on pin EVI
4. Set the ET field to apply filtering to the EVI pin. See following two diagrams.
5. Set the ERST bit to 1 if you want to reset the 100th Seconds, Seconds CP and 100th Seconds CP registers to 0 in case of an event detection. After the event detection, the ERST bit is reset to 0.
6. Set the EIE bit to 1 if you want to get a hardware interrupt on $\overline{\text{INT}}$ pin.

ET = 00. Example with positive edge detection:

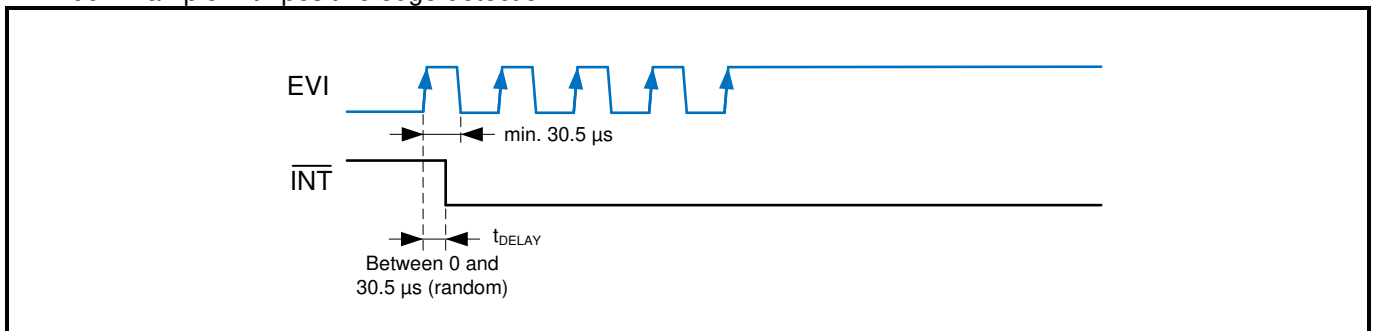

With digital debounce filter: ET = 01, 10 or 11 (sampling period t_{SP} = 3.9 ms, 15.6 ms or 125 ms). Example with positive edge/level detection:

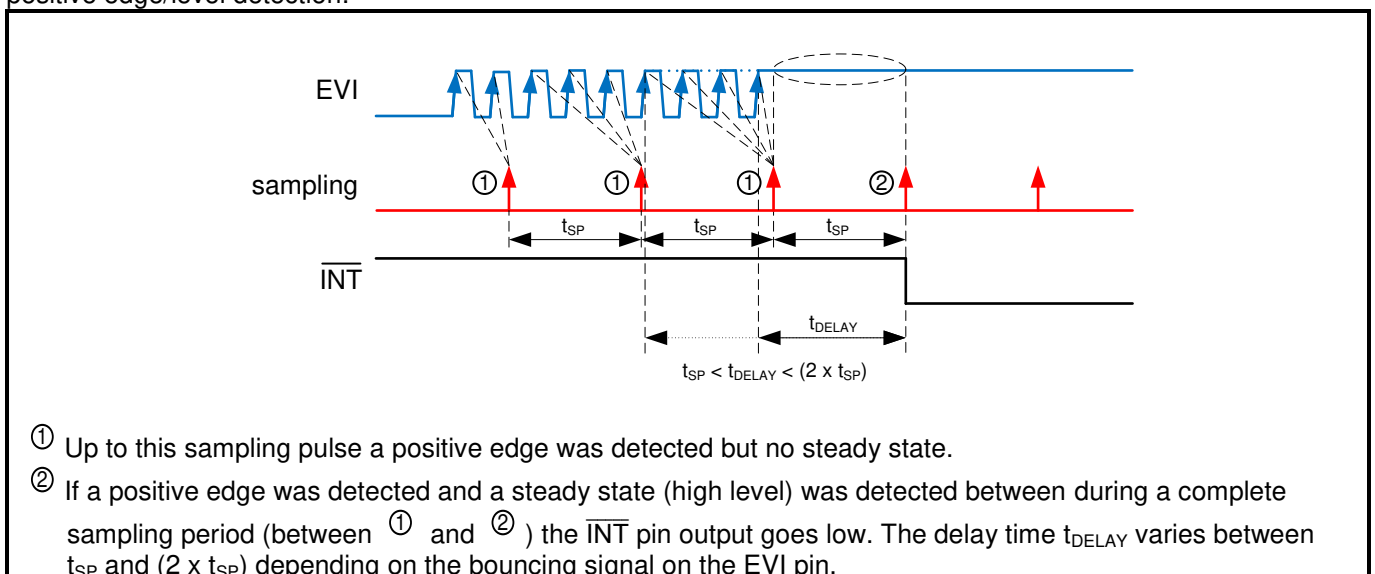

- ① Up to this sampling pulse a positive edge was detected but no steady state.
- ② If a positive edge was detected and a steady state (high level) was detected between during a complete sampling period (between ① and ②) the $\overline{\text{INT}}$ pin output goes low. The delay time t_{DELAY} varies between t_{SP} and $(2 \times t_{\text{SP}})$ depending on the bouncing signal on the EVI pin.

4.9. CLKOUT FREQUENCY SELECTION

A programmable square wave is available at pin CLKOUT. Operation is controlled by the FD field in the EXTENSION REGISTER. Frequencies of 32.768 kHz (default), 1024 Hz and 1 Hz can be generated for use as a system clock, microcontroller clock, input to a charge pump, or for calibration of the crystal oscillator.

Pin CLKOUT is a push-pull output that is enabled at power-on (when CLKOE is HIGH). CLKOUT can be disabled by setting CLKOE pin LOW. When disabled, the CLKOUT pin is high impedance (tri-state).

The RESET bit function can affect the CLKOUT signal depending on the selected frequency. When the RESET bit is set logic 1 and the CLKOE pin is HIGH, the CLKOUT pin generates a continuous HIGH or LOW for the 1024 Hz and 1 Hz frequency (for more details, see RESET BIT FUNCTION).

For this table, CLKOE is HIGH.

FD	CLKOUT Frequency	Typical duty cycle	If RESET bit = 1	If ERST bit = 1
00	32.768 kHz – Default value	50 ±10 %	no effect	no effect
01	1024 Hz ⁽¹⁾	50 %	CLKOUT is HIGH or LOW (2)	no effect
10	1 Hz	50 %	CLKOUT is HIGH or LOW (2)	no effect
11	32.768 kHz	50 ±10 %	no effect	no effect

⁽¹⁾ 1024 Hz clock pulses are affected by compensation pulses (see TEMPERATURE COMPENSATION and AGING CORRECTION).
⁽²⁾ 1024 Hz and 1 Hz are synchronously turned on and off by the RESET bit.

See also 32.768 KHZ ENABLE/DISABLE TIMING.

4.10. DIGITAL ARCHITECTURE SUMMARY

The following Figure illustrates the overall architecture of the pin inputs and outputs of the RV-8803-C7.

Digital Architecture Summary:

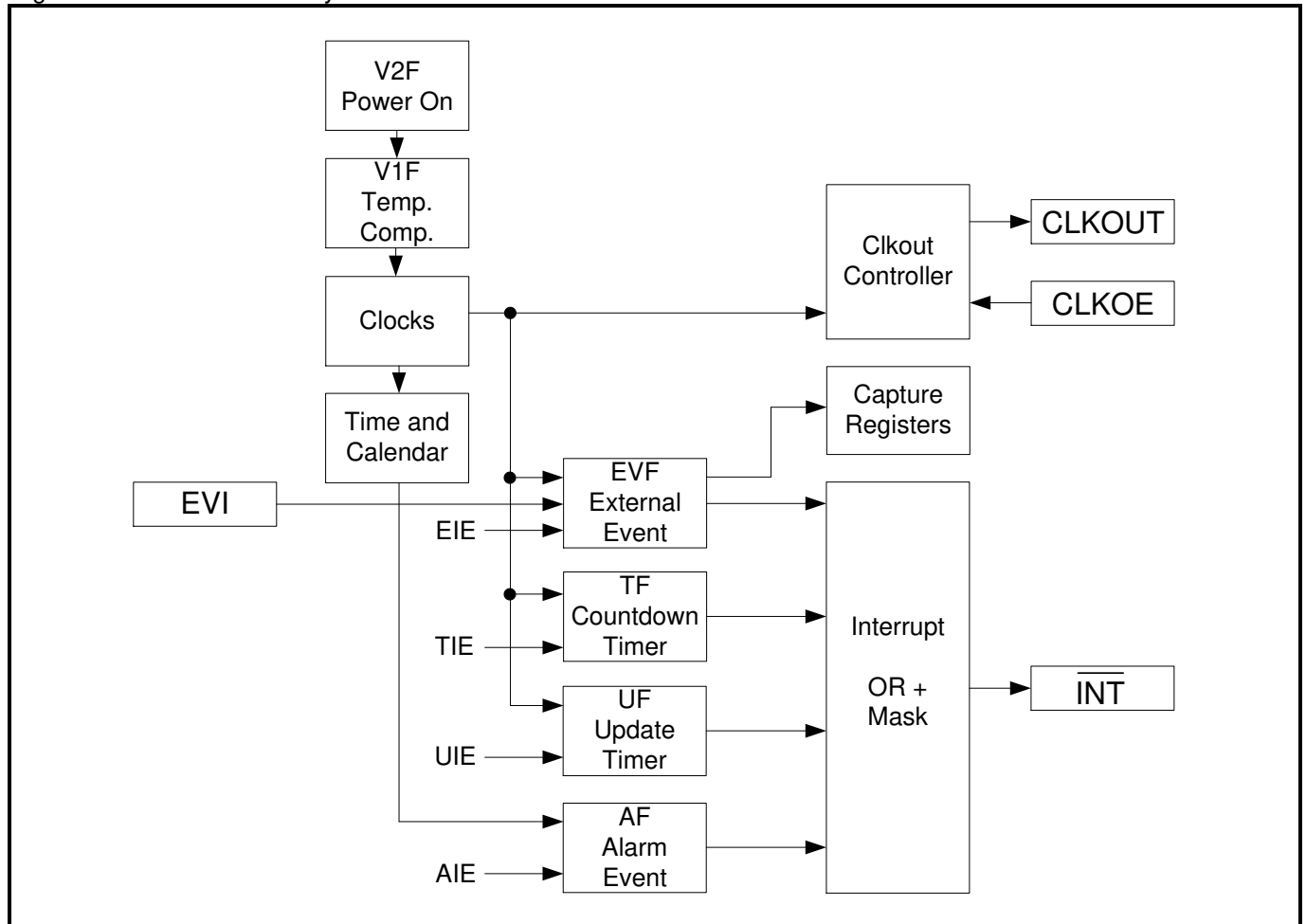

4.11. SYNCHRONICITY BETWEEN $\overline{\text{INT}}$ SIGNALS AND 1 HZ CLKOUT

The following Figure illustrates the synchronicity between the $\overline{\text{INT}}$ signals from the Periodic Time Update Interrupt function and Periodic Countdown Timer Interrupt function to the 1 Hz CLKOUT signal.

Synchronicity between the $\overline{\text{INT}}$ signals and the 1 Hz CLKOUT:

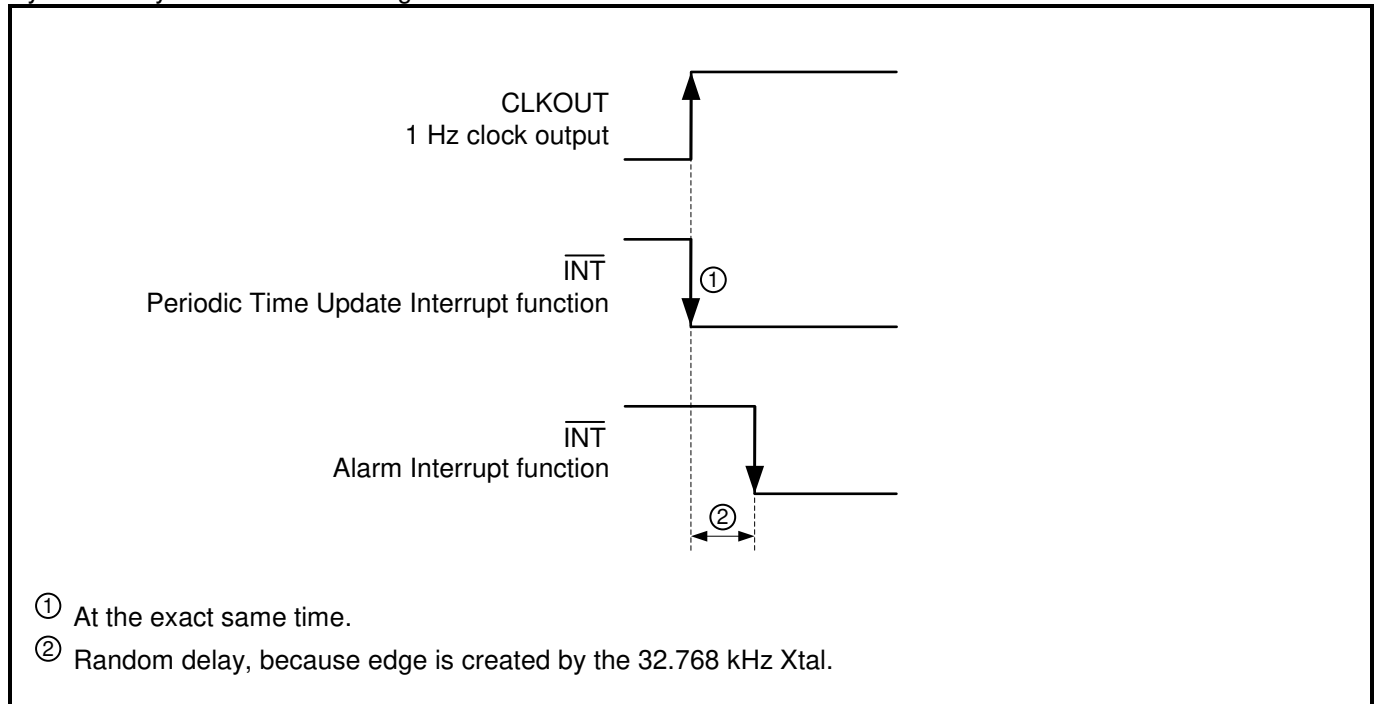

4.12. TIME DATA READ-OUT

In order to not corrupt the accuracy of the temperature compensation and the Time Capture (Time Stamp) function on the highest 100th Seconds resolution, it is not possible to freeze the clock and calendar register during read-out process, as it is common practice for other RTC's.

Since the time and calendar registers cannot be frozen, there might be a condition that the time registers are incremented by one 1 Hz tick while read-out. Therefore, reading should be completed within one second and to avoid corrupted (partially incremented) data, special measures and procedures need to be applied.

4.12.1. PROCEDURE

If a time read-out sequence starts at the end of a minute there is a special condition that subsequent registers might be incremented by the time update.

Example with faulty reading:

Expected time read-out = mm:ss = 01:59

1. mm:ss = 01:59 read Seconds = 59
mm:ss = 02:00 one 1 Hz tick incremented
2. mm:ss = 02:00 read Minutes = 02

Effective faulty time read-out = mm:ss = 02:59; the failure is 1 minute.

To prevent using corrupted data from partially incremented time and calendar registers, it is recommended to repeat and confirm time and calendar data when reading Seconds = 59 (see following METHODE TO CONFIRM CORRECT TIME AND CALENDAR READ-OUT).

4.12.2. METHODE TO CONFIRM CORRECT TIME AND CALENDAR READ-OUT

When reading Seconds = 59, it is recommended to repeat and compare the read-out of the Seconds register. If the Seconds register data matches, it confirms that the time and calendar data are valid (no time increment occurred during data read-out). If the Seconds value has changed to 00, the second set of time and calendar data is valid.

1. Read required time and calendar information.
2. If Seconds data = 59, a repeated reading is required.
3. If Seconds data is again 59 seconds, then the first data from the first reading is confirmed to be valid.
4. If the Seconds register was incremented (not 59 seconds anymore), then the time and calendar information has been incremented and the second set of data is confirmed to be valid (the first set of data is supposed to be partially incremented during the read-out sequence and therefore is invalid).

4.13. RESET BIT FUNCTION

The RESET bit is used for a software-based accurate and safe starting of the time circuits.

The RESET bit function causes the upper part of the prescaler (F_2 to F_{14}) to be held in reset and thus no 1 Hz ticks are generated. The RESET bit function will not affect the CLKOUT of 32.768 kHz (see also CLKOUT FREQUENCY SELECTION).

RESET bit functional diagram:

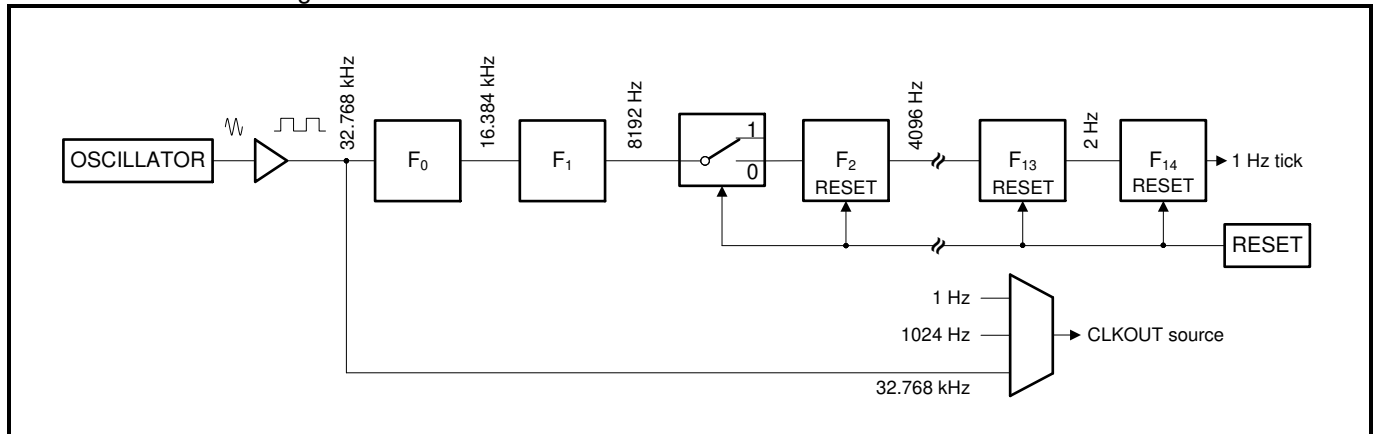

The time circuits can then be set and do not increment until the RESET bit is released.

Setting the clock and calendar values using the RESET bit function:

1. Set RESET bit to 1 to prevent a timer update while setting the time.
2. Write the desired clock and calendar values to the registers (year, month, date, weekday, hours, minutes and seconds). The 100th seconds register was cleared to 00 when setting the RESET bit to 1.
3. Release RESET bit to 0 to start the time circuits.

4.14. ERST BIT FUNCTION

The Event Reset bit ERST is used for an external event triggered highly accurate time adjustment (synchronizing).

If the ERST bit is 1 and in case of an External Event detection on the EVI pin, the prescaler and counters at below the second are reset to 0 (2 Hz to 8 kHz). This means that the 100th Seconds Register (100 Hz) is reset to 0. Moreover, the time stamp in the 100th Seconds CP and Seconds CP registers are also reset to 0, whatever the ECP value is. After the event detection, the ERST bit is reset to 0 automatically.

Setting the clock and calendar values synchronous to an External Event detection:

1. Initialize the External Event Function according to USE OF THE EXTERNAL EVENT FUNCTION with bits EIE and ERST set to 1.
2. When interrupt pin \overline{INT} is triggered by the External Event Function, write the desired clock and calendar values to the registers (year, month, date, weekday, hours, minutes and seconds). The 100th Seconds register is cleared to 00 automatically.
3. After the event detection, the ERST bit is reset to 0 automatically.

See also EXTERNAL EVENT FUNCTION.

5. TEMPERATURE COMPENSATION

5.1. FREQUENCIES

Xtal 32.768 kHz

The Xtal 32.768 kHz clock is not temperature compensated. Due to its negative temperature coefficient with a parabolic frequency deviation, a change of up to -150 ppm across the standard operating temperature range of -40°C to +85°C can result (for the extended operating range of -40°C to 105°C a frequency change of -225 ppm can result). The 32.768 kHz oscillator frequency on all devices is tested not to exceed a time deviation of ±20 ppm (parts per million) at 25°C.

Frequencies from 4096 Hz to 64 Hz

These frequencies are digitally temperature compensated with a Time Accuracy of ±3 ppm over the standard temperature range of -40°C to +85°C and of ±7 ppm for the extended temperature range from +85°C to 105°C. The clock at the 16.384 kHz level of the divider chain is modified by adding or subtracting 32.768 kHz level pulses. The pulses are added or subtracted according to the expected frequency deviation computed by the temperature compensation algorithm. The digital compensation method (adding and subtracting clock pulses) is affecting the cycle-to-cycle jitter of the digitally compensated frequencies shown below.

- 4096 Hz (Periodic Countdown Timer Interrupt)
- 1024 Hz (CLKOUT)
- 100 Hz (External Event Interrupt)
- 64 Hz (Periodic Countdown Timer Interrupt)

Aging compensation can be done with the OFFSET value (see AGING CORRECTION).

1 Hz and Clock / Calendar

The 1 Hz clock is temperature compensated and using both, digital coarse compensation and digital fine adjustment. The Time Accuracy and the Frequency Accuracy is ±3 ppm for every 1 Hz period over the standard temperature range of -40°C to +85°C and ±7 ppm for the extended temperature range from +85°C to +105°C. The temperature compensation algorithm adjusts every 1 Hz period with a resolution of about 0.1 ppm. This precise and accurate 1 Hz clock is used to increment all subsequent clock and calendar registers.

Aging compensation can be done with the OFFSET value (see AGING CORRECTION).

5.2. TIME ACCURACY VS. TEMPERATURE CHARACTERISTICS

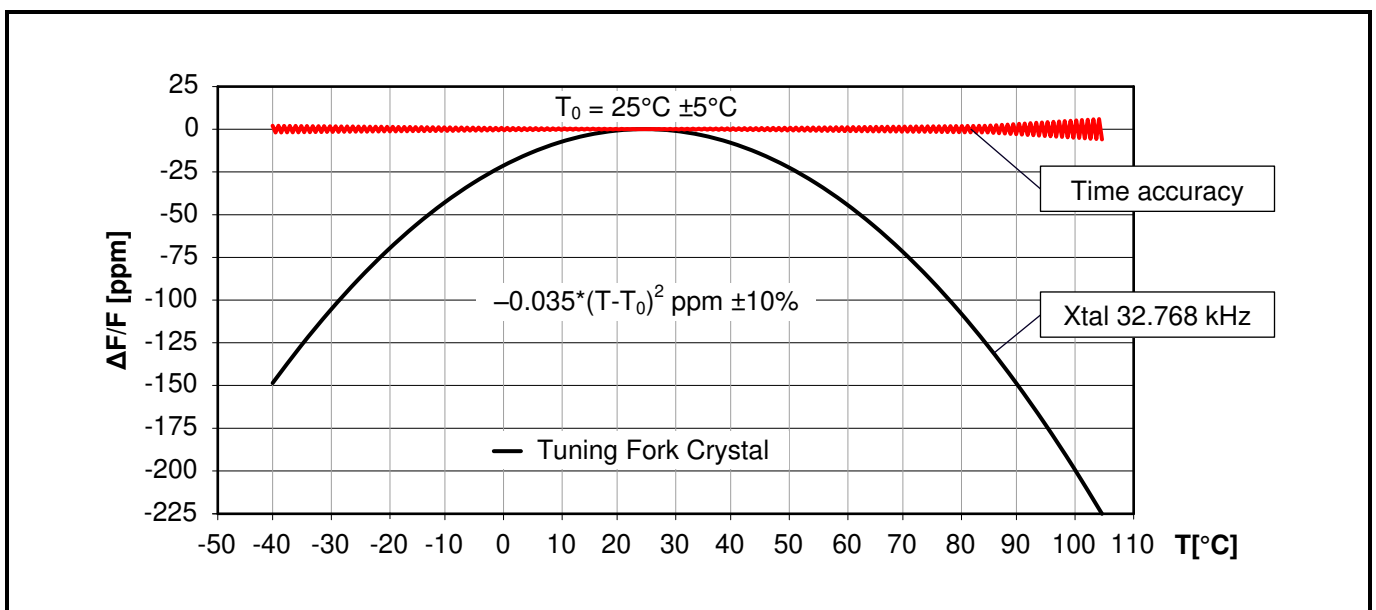

5.3. COMPENSATION VALUES

Each device is factory calibrated over the full temperature range, and the individual compensation values are stored in the EEPROM of the Digital Temperature Compensation Unit (DTCU). The EEPROM is not accessible for the user.

5.4. AGING CORRECTION

An aging adjustment or accuracy tuning can be done with the OFFSET value. The correction is purely digitally and has only the effect of shifting the time vs. temperature curve vertically up or down. It has no effect on the time vs. temperature characteristics of the final frequency. The OFFSET value contains a two's complement number with a range of -2^6 to $+2^6-1$ adjustment steps. The minimal correction step (one LSB) is $\pm 1/(32768*128) = \pm 0.2384$ ppm. The maximum correction range is roughly ± 7.4 ppm. Note that the signed offset value OFFSET corresponds to the actual offset value of the measured frequency. The user has access to this field (see OFFSET REGISTER).

The OFFSET value is determined by the following process:

1. Set the OFFSET field to 0 to ensure correction is not occurring.
2. Select the 1 Hz frequency on the CLKOUT pin.
3. Measure the frequency F_{meas} at the output pin in Hz.
4. Compute the offset value required in ppm: $P_{Offset} = ((F_{meas} - 1) * 1'000'000)$
5. Compute the offset value in steps: $Offset = P_{Offset} / (1 / (32768 * 128)) = P_{Offset} / (0.2384)$
6. If $Offset > 31$, the frequency is too high to be corrected.
7. Else if $0 \leq Offset \leq 31$, set $OFFSET = Offset$
8. Else if $-32 \leq Offset \leq -1$, set $OFFSET = Offset + 64$
9. Else the frequency is too low to be corrected.

Examples:

- If 1.0000012 Hz is measured when the 1 Hz clock is selected, the offset is +0.0000012 Hz, which is $+0.0000012 \text{ Hz} / 10^{-6} \text{ Hz} = +1.2$ ppm. The positive offset value is then calculated as follows: $+1.2 \text{ ppm} / 0.2384 \text{ ppm} = +5.03$, the rounded integral part is +5. In binary, $OFFSET = 000101$.
- If 0.9999949 Hz is measured when the 1 Hz clock is selected, the offset is -0.0000051 Hz, which is $-0.0000051 \text{ Hz} / 10^{-6} \text{ Hz} = -5.1$ ppm. The negative offset value is then calculated as follows: $-5.1 \text{ ppm} / 0.2384 \text{ ppm} = -21.39$, the rounded integral part is -21. The unsigned value is then $-21 + 64 = +43$. In binary, $OFFSET = 101011$.

5.5. CLOCKING SCHEME

Clocking Scheme with CLKOUT and Interrupts:

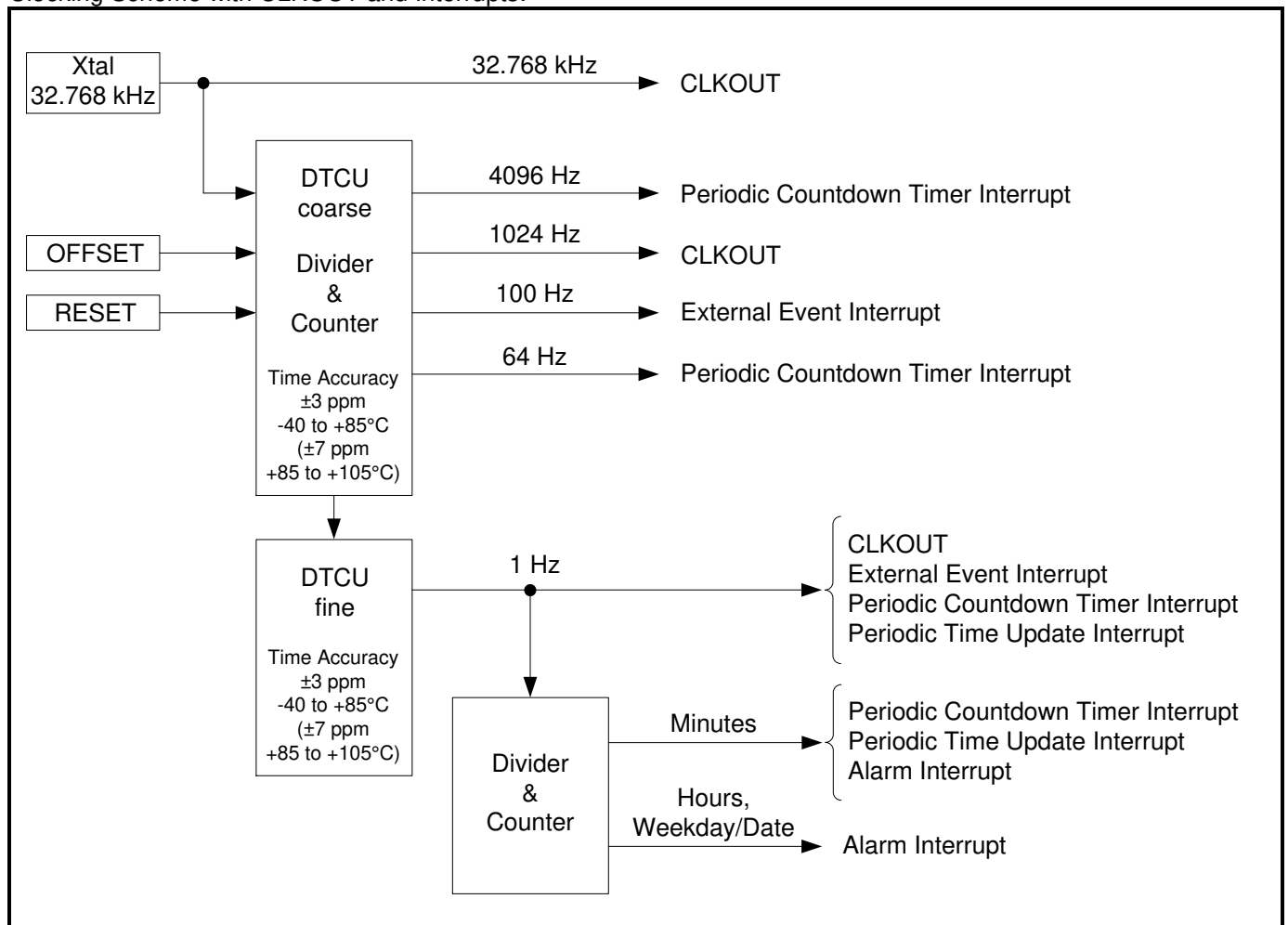

5.6. MEASURING TIME ACCURACY AT CLKOUT PIN

The simplest method to verify the time accuracy of the Digital Temperature Compensation Unit (DTCU) is to measure the compensated 1 Hz frequency at the CLKOUT pin. The 1 Hz clock frequency contains digitally temperature compensation clocks with digital fine adjustment and represents the fully time accuracy of the device.

5.6.1. MEASURING 1 HZ AT CLKOUT PIN

1. Select the 1 Hz frequency at CLKOUT:
 - a. Set the FD field to 10 = 1 Hz (see EXTENSION REGISTER, 0Dh, 1Dh).
 - b. Set the CLKOUT pin into output mode by setting the CLKOE pin to high level.
2. Measuring equipment and setup:
 - a. Use a high-precision universal counter to observe the 1 Hz frequency accuracy on CLKOUT pin.
 - b. Trigger on the rising edge of the hybrid signal (gate time ≥ 1 second). Each 1 Hz clock measured at the rising edge fully representing the accuracy of the DTCU.

1 Hz time accuracy at CLKOUT pin (hybrid signal):

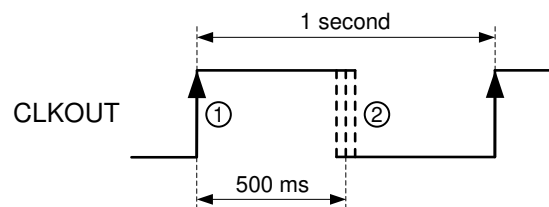

- ① CLKOUT Output is active HIGH.
When measuring the time accuracy it is mandatory to trigger on the rising edge of the CLKOUT signal. The resolution of the compensated 1 Hz period is about 0.1 ppm (minimal step).
- ② The falling edge of the CLKOUT signal is generated when the RV-8803-C7 clears the signal after 500 ms. The negative edge is created by the 32.768 kHz Xtal and must not be used to test the time accuracy.

5.7. MEASURING TIME ACCURACY AT $\overline{\text{INT}}$ PIN

The Periodic Time Update Interrupt function can also be used to verify the time accuracy of the Digital Temperature Compensation Unit (DTCU) by measuring the compensated 1 Hz frequency at the $\overline{\text{INT}}$ output pin. However this procedure is a little more sophisticated than using the method with the CLKOUT pin.

5.7.1. MEASURING 1 HZ WITH THE PERIODIC TIME UPDATE INTERRUPT FUNCTION

1. Select the Periodic Time Update Interrupt function with the frequency 1 Hz at the $\overline{\text{INT}}$ output pin:
 - a. Write 0 to UIE and UF bits
 - b. Choose USEL = 0 = 1 Hz, $t_{\text{RTN2}} = 500$ ms (Default value) (see EXTENSION REGISTER, 0Dh, 1Dh)
 - c. Set UIE bit to 1 to enable the Periodic Time Update Interrupt function with hardware interrupt on $\overline{\text{INT}}$ pin.
 - d. The first interrupt will occur after the next event.

2. Measuring equipment and setup:
 - a. Use a high-precision universal counter to observe the frequency stability on $\overline{\text{INT}}$ output pin.
 - b. If measuring the 1 Hz clock it suffices to measure only one period to verify the time accuracy. Trigger on the falling edge of the hybrid signal (gate time ≥ 1 second).

1 Hz time accuracy at $\overline{\text{INT}}$ pin with the Periodic Time Update Interrupt function (hybrid signal):

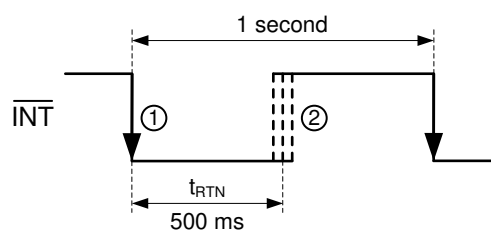

- ① $\overline{\text{INT}}$ Output is active LOW.
When measuring the time accuracy it is mandatory to trigger on the falling edge of the $\overline{\text{INT}}$ signal. The resolution of the compensated 1 Hz period is about 0.1 ppm (minimal step).
- ② The rising edge of the $\overline{\text{INT}}$ signal is generated when the RV-8803-C7 clears the signal after the auto reset time $t_{\text{RTN2}} = 500$ ms. The positive edge is created by the 32.768 kHz Xtal and must not be used to test the time accuracy.

6. I²C INTERFACE

The I²C interface is for bidirectional, two-line communication between different ICs or modules. The RV-8803-C7 is accessed at addresses 64h/65h, and supports Fast Mode (up to 400 kHz). The I²C interface consists of two lines: one bi-directional data line (SDA) and one clock line (SCL). Both lines are connected to a positive supply via pull-up resistors. Data transfer is initiated only when the interface is not busy.

6.1. BIT TRANSFER

One data bit is transferred during each clock pulse. The data on the SDA line remains stable during the HIGH period of the clock pulse, as changes in the data line at this time are interpreted as control signals. Data changes should be executed during the LOW period of the clock pulse (see Figure below).

Bit transfer:

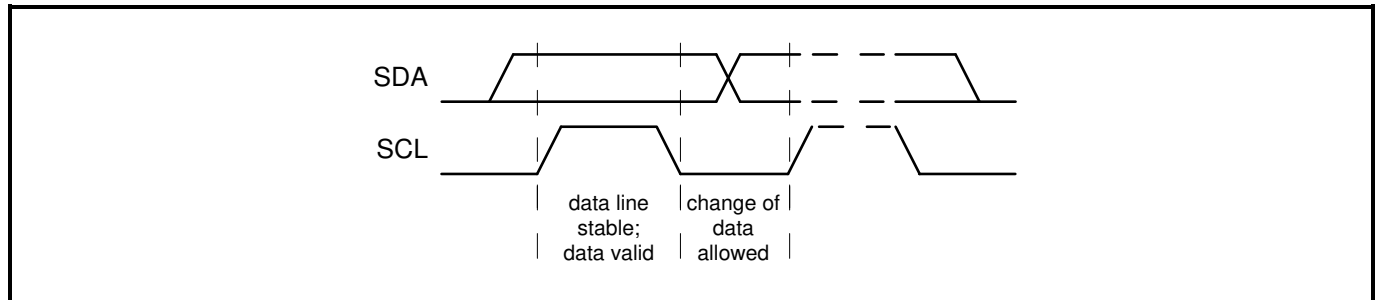

6.2. START AND STOP CONDITIONS

Both data and clock lines remain HIGH when the bus is not busy. A HIGH-to-LOW transition of the data line, while the clock is HIGH, is defined as the START condition (S). A LOW-to-HIGH transition of the data line, while the clock is HIGH, is defined as the STOP condition (P) (see Figure below).

Definition of START and STOP conditions:

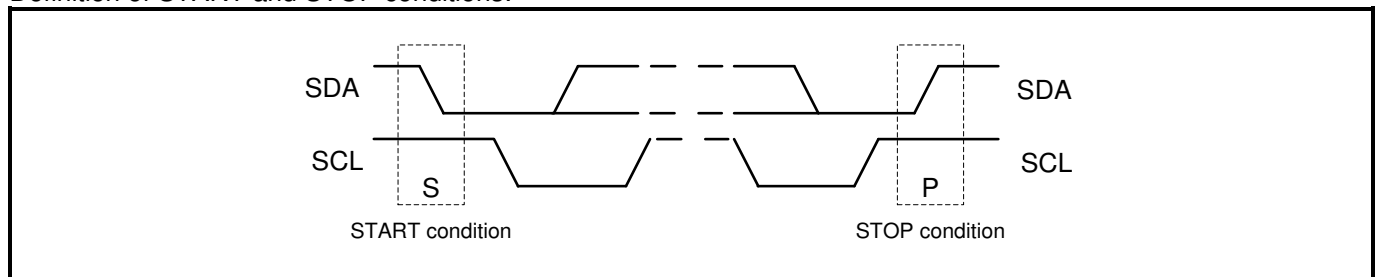

A START condition which occurs after a previous START but before a STOP is called a Repeated START condition, and functions exactly like a normal STOP followed by a normal START.

6.3. DATA VALID

After a START condition, SDA is stable for the duration of the high period of SCL. The data on SDA may be changed during the low period of SCL. There is one clock pulse per bit of data. Each data transfer is initiated with a START condition and terminated with a STOP condition. The number of data bytes transferred between the START and STOP conditions is not limited. The information is transmitted byte-wise and each receiver acknowledges with a ninth bit.

In order to not corrupt the accuracy of the temperature compensation and the Time Capture (Time Stamp) function on the highest 100th Seconds resolution, it is not possible to freeze the clock and calendar register during read-out process, as it is common practice for other RTC's.

Since the time and calendar registers cannot be frozen, there might be a condition that the time registers are incremented while read-out. To avoid reading corrupted (partially incremented) data, special measures and procedures need to be applied (see TIME DATA READ-OUT).

6.4. SYSTEM CONFIGURATION

Since multiple devices can be connected with the I²C-bus, all I²C-bus devices have a fixed and unique device number built-in to allow individual addressing of each device.

The device that controls the I²C-bus is the Master; the devices which are controlled by the Master are the Slaves. A device generating a message is a Transmitter; a device receiving a message is the Receiver. The RV-8803-C7 acts as a Slave-Receiver or Slave-Transmitter.

Before any data is transmitted on the I²C-bus, the device which should respond is addressed first. The addressing is always carried out with the first byte transmitted after the START procedure. The clock signal SCL is only an input signal, but the data signal SDA is a bidirectional line.

System configuration:

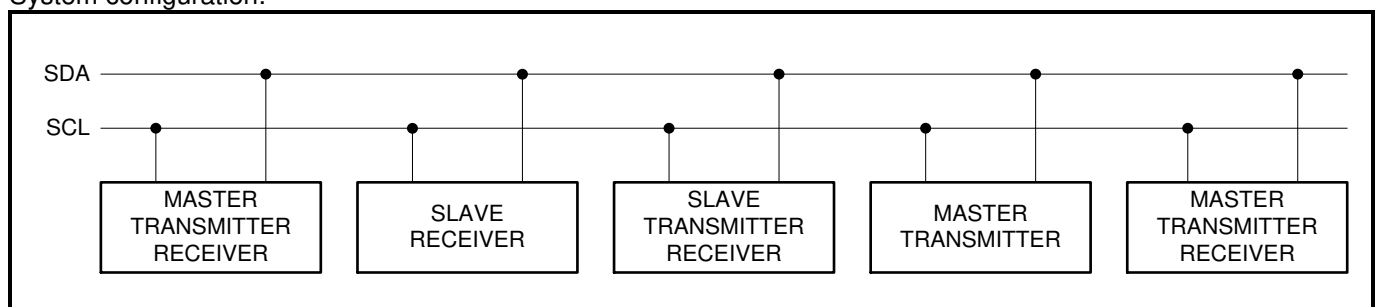

6.5. ACKNOWLEDGE

The number of data bytes transferred between the START and STOP conditions from transmitter to receiver is unlimited. Each byte of eight bits is followed by an acknowledge cycle.

- A slave receiver, which is addressed, must generate an acknowledge cycle after the reception of each byte.
- Also a master receiver must generate an acknowledge cycle after the reception of each byte that has been clocked out of the slave transmitter.
- The device that acknowledges must pull-down the SDA line during the acknowledge clock pulse, so that the SDA line is stable LOW during the HIGH period of the acknowledge-related clock pulse (set-up and hold times must be taken into consideration).
- A master receiver must signal an end of data to the transmitter by not generating an acknowledge cycle on the last byte that has been clocked out of the slave. In this event the transmitter must leave the data line HIGH to enable the master to generate a STOP condition.

Data transfer and acknowledge on the I²C-bus:

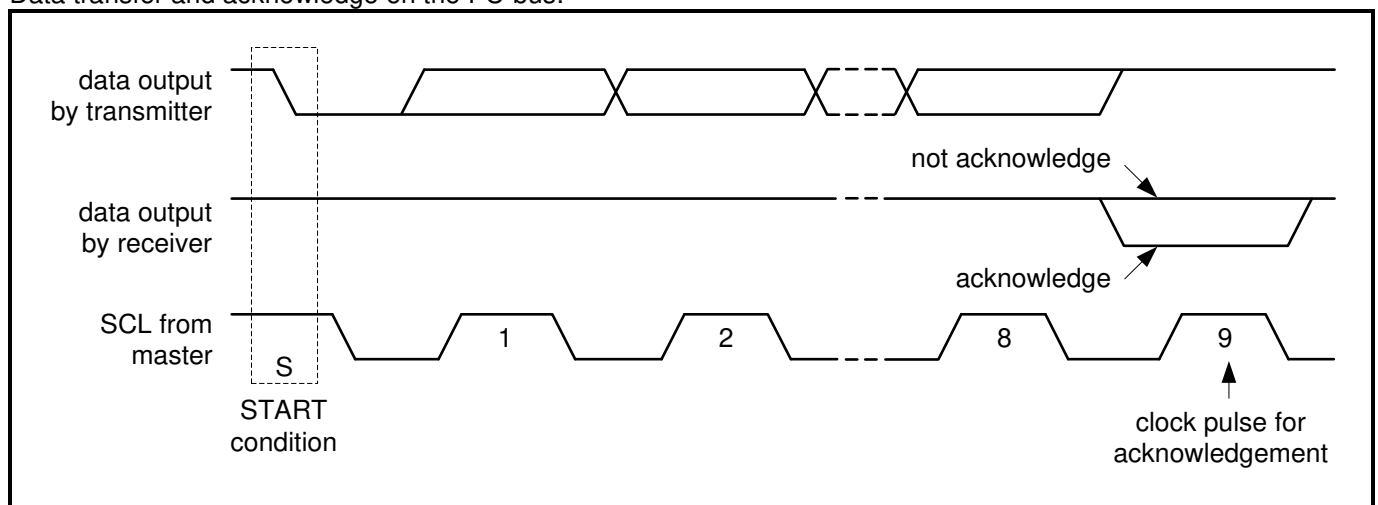

6.6. SLAVE ADDRESS

On the I²C-bus the 7-bit slave address 0110010b is reserved for the RV-8803-C7. The entire I²C-bus slave address byte is shown in the following table.

Slave address							R/ \bar{W}	Transfer data
Bit 7	Bit 6	Bit 5	Bit 4	Bit 3	Bit 2	Bit 1	Bit 0	
0	1	1	0	0	1	0	1 (R)	65h (read)
							0 (\bar{W})	64h (write)

After a START condition, the I²C slave address has to be sent to the RV-8803-C7 device. The R/ \bar{W} bit defines the direction of the following single or multiple byte data transfer. The 7-bit address is transmitted MSB first. If this address is 0110010b, the RV-8803-C7 is selected, the eighth bit indicates a read (R/ \bar{W} = 1) or a write (R/ \bar{W} = 0) operation (results in 65h or 64h) and the RV-8803-C7 supplies the ACK. The RV-8803-C7 ignores all other address values and does not respond with an ACK.

In the write operation, a data transfer is terminated by sending either the STOP condition or the START condition of the next data transfer.

6.7. WRITE OPERATION

Master transmits to Slave-Receiver at specified address. The Register Address is an 8-bit value that defines which register is to be accessed next. After writing one byte, the Register Address is automatically incremented by 1.

Master writes to slave RV-8803-C7 at specific address:

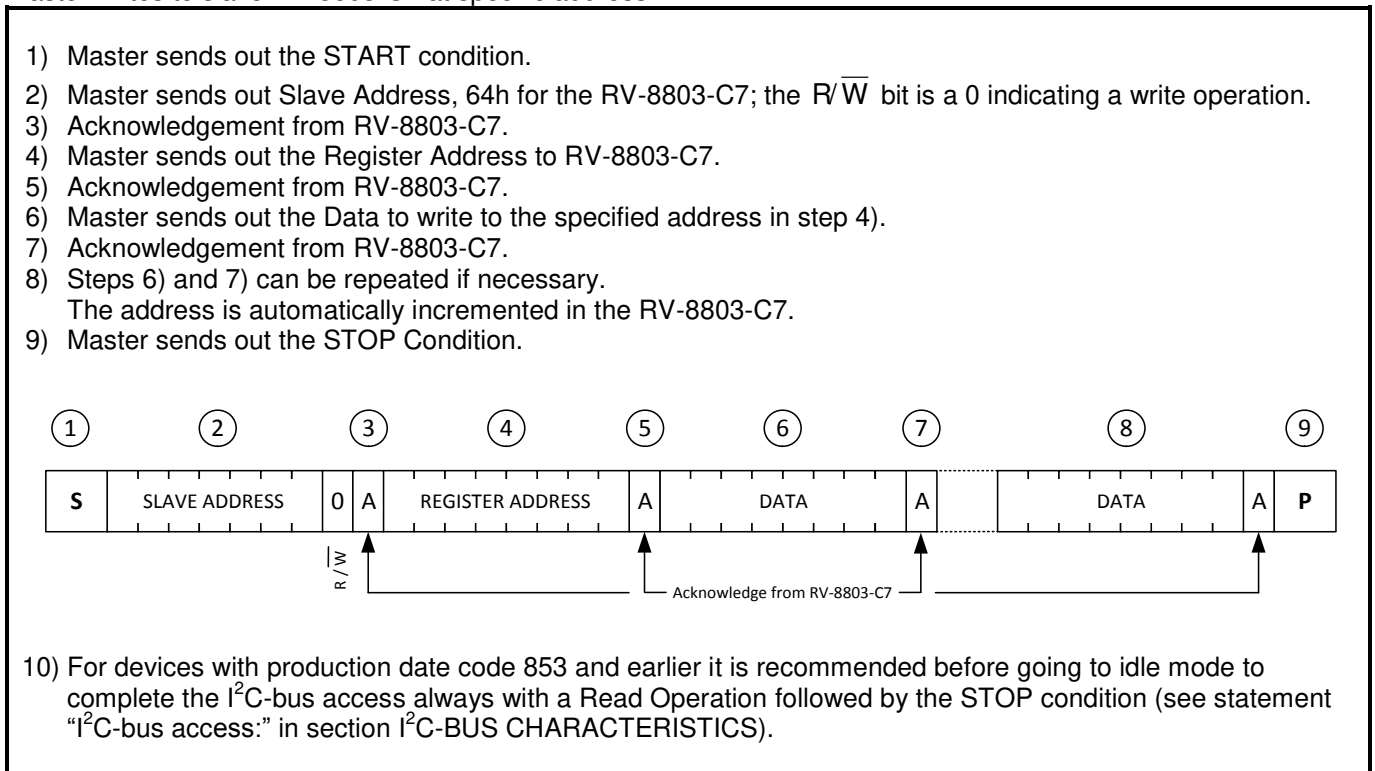

6.8. READ OPERATION AT SPECIFIC ADDRESS

Master reads data from slave RV-8803-C7 at specific address:

- 1) Master sends out the START condition.
- 2) Master sends out Slave Address, 64h for the RV-8803-C7; the $\overline{R/\overline{W}}$ bit is a 0 indicating a write operation.
- 3) Acknowledgement from RV-8803-C7.
- 4) Master sends out the Register Address to RV-8803-C7.
- 5) Acknowledgement from RV-8803-C7.
- 6) Master sends out the Repeated START condition (or STOP condition followed by START condition)
- 7) Master sends out Slave Address, 65h for the RV-8803-C7; the $\overline{R/\overline{W}}$ bit is a 1 indicating a read operation.
- 8) Acknowledgement from RV-8803-C7.
- At this point, the Master becomes a Receiver and the Slave becomes the Transmitter.
- 9) The Slave sends out the Data from the Register Address specified in step 4).
- 10) Acknowledgement from Master.
- 11) Steps 9) and 10) can be repeated if necessary.
- The address is automatically incremented in the RV-8803-C7.
- 12) The Master, addressed as Receiver, can stop data transmission by not generating an acknowledge on the last byte that has been sent from the Slave-Transmitter. In this event, the Slave-Transmitter must leave the data line HIGH to enable the Master to generate a STOP condition.
- 13) Master sends out the STOP condition.

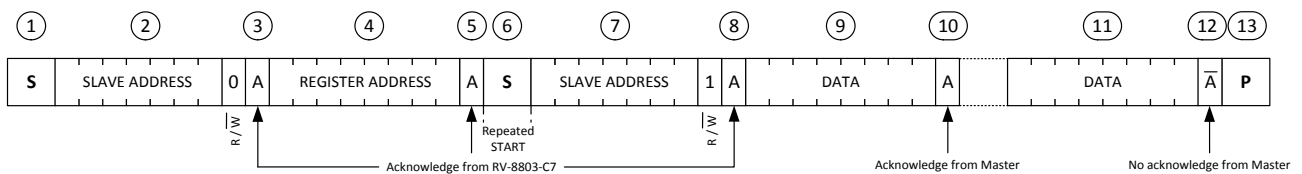

6.9. READ OPERATION

Master reads data from slave RV-8803-C7 immediately after first byte:

- 1) Master sends out the START condition.
- 2) Master sends out Slave Address, 65h for the RV-8803-C7; the $\overline{R/\overline{W}}$ bit is a 1 indicating a read operation.
- 3) Acknowledgement from RV-8803-C7.
At this point, the Master becomes a Receiver and the Slave becomes the Transmitter.
- 4) The RV-8803-C7 sends out the Data from the last accessed Register Address incremented by 1.
- 5) Acknowledgement from Master.
- 6) Steps 4) and 5) can be repeated if necessary.
The address is automatically incremented in the RV-8803-C7.
- 7) The Master, addressed as Receiver, can stop data transmission by not generating an acknowledge on the last byte that has been sent from the Slave-Transmitter. In this event, the Slave-Transmitter must leave the data line HIGH to enable the Master to generate a STOP condition.
- 8) Master sends out the STOP condition.

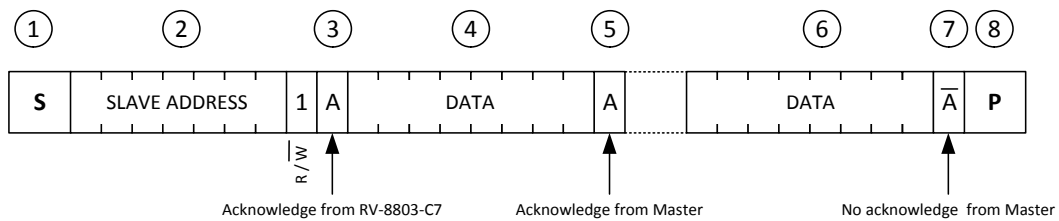

6.10. FREE-CLOCKING I²C-BUS

When the I²C Master goes through a reset (e.g. power down) right in the middle of transmitting or receiving a byte from the RV-8803-C7, the RV-8803-C7 is not aware of the reset and since the RV-8803-C7 does not have a timeout function it may well wait for the next clock event to send or receive a bit, not listening to any start condition which is likely to occur after a reset as startup sequence. When RV-8803-C7 holds SDA low the I²C-bus is blocked. Now it is the master’s job to recover the bus and restore control to the main program. If the data line (SDA) is stuck LOW, the master has to clear it.

The following procedure is recommended:

1. Master tries to assert a Logic 1 on the SDA line
2. Master still sees a Logic 0 and then generates a clock pulse on SCL 0-1-0 (LOW-HIGH-LOW)
3. Master examines SDA:
 - If SDA = 0, go to Step 2; this loop may be required up to 9 times.
 - If SDA = 1, go to Step 4
4. Generate a STOP condition

7. ELECTRICAL SPECIFICATIONS

7.1. ABSOLUTE MAXIMUM RATINGS

The following Table lists the absolute maximum ratings.

Absolute Maximum Ratings according to IEC 60134:

SYMBOL	PARAMETER	CONDITIONS	MIN	TYP	MAX	UNIT
V _{DD}	Power Supply Voltage		-0.3		6.0	V
V _I	Input voltage	Input Pin	-0.3		V _{DD} +0.3	V
V _O	Output voltage	Output Pin	-0.3		V _{DD} +0.3	V
I _I	Input current		-10		10	mA
I _O	Output current		-10		10	mA
V _{ESD}	ESD Voltage	HBM ⁽¹⁾			±2000	V
		MM ⁽²⁾			±200	V
I _{LU}	Latch-up Current	Jedec ⁽³⁾			±100	mA
T _{OPR}	Operating Temperature		-40		+85 ⁽⁴⁾	°C
T _{STO}	Storage Temperature		-55		+125	°C
T _{PEAK}	Maximum reflow condition	JEDEC J-STD-020C			+265	°C

(1) HBM: Human Body Model, according to JESD22-A114.
(2) MM: Machine Model, according to JESD22-A115.
(3) Latch-up testing, according to JESD78., Class I (room temperature), level A (100 mA).
(4) Supports extended operating temperature range from +85°C to +105°C with limitations.

7.2. OPERATING PARAMETERS

For this Table, $T_A = -40^{\circ}\text{C}$ to $+85^{\circ}\text{C}$ unless otherwise indicated. $V_{DD} = 1.5$ to 5.5 V, $f_{OSC} = 32.768$ kHz, TYP values at 25°C and 3.0 V.

Operating Parameters:

SYMBOL	PARAMETER	CONDITIONS	MIN	TYP	MAX	UNIT
Supplies						
V_{DD}	Power Supply Voltage	Time-keeping mode ⁽²⁾	1.5		5.5	V
		I ² C-bus (100 kHz)	1.5		5.5	
		I ² C-bus (400 kHz)	2.0		5.5	
$V_{DD:EXT}$	Power Supply Voltage for extended temperature range	Time-keeping mode, $T_A = +85^{\circ}\text{C}$ to $+105^{\circ}\text{C}$ ⁽²⁾	1.6		5.5	V
		I ² C-bus (100 kHz), $T_A = +85^{\circ}\text{C}$ to $+105^{\circ}\text{C}$	1.6		5.5	
		I ² C-bus (400 kHz), $T_A = +85^{\circ}\text{C}$ to $+105^{\circ}\text{C}$	2.1		5.5	
V_{DDF}	V_{DD} falling slew rate ⁽¹⁾				0.5	V/ μs
V_{DDR2}	V_{DD} rising slew rate ⁽¹⁾	Rising from $V_{DD} = 1.5$ V to $V_{DD} \leq 3.5$ V			0.2	V/ μs
		Rising from $V_{DD} = 1.5$ V to $V_{DD} > 3.5$ V			0.07	
V_{LOW1}	V_{DD} low and POR detection. Temperature compensation stops (flag V1F). ⁽³⁾		1.1	1.2	1.3	V
V_{LOW2}	V_{DD} low and POR detection. Data no longer valid (flag V2F). ⁽³⁾		1.1	1.2	1.3	V
I_{VDD}	V_{DD} supply current timekeeping I ² C-bus inactive, CLKOUT disabled, average current	$V_{DD} = 1.5$ V ⁽⁴⁾		240	600	nA
		$V_{DD} = 3.0$ V ⁽⁴⁾		240	600	
		$V_{DD} = 5.0$ V ⁽⁴⁾		250	700	
$I_{VDD:EXT}$	V_{DD} supply current timekeeping I ² C-bus inactive, CLKOUT disabled, average current for extended temperature range	$V_{DD} = 1.6$ V, $+85$ to $+105^{\circ}\text{C}$ ⁽⁴⁾			800	nA
		$V_{DD} = 3.0$ V, $+85$ to $+105^{\circ}\text{C}$ ⁽⁴⁾			800	
		$V_{DD} = 5.0$ V, $+85$ to $+105^{\circ}\text{C}$ ⁽⁴⁾			900	
$I_{VDD:I2C}$	V_{DD} supply current during I ² C burst read/write, CLKOUT disabled	$V_{DD} = 1.5$ V, SCL = 100 kHz ⁽⁵⁾		2	15	μA
		$V_{DD} = 3.0$ V, SCL = 400 kHz ⁽⁵⁾		5	40	
		$V_{DD} = 5.0$ V, SCL = 400 kHz ⁽⁵⁾		7	60	
$I_{VDD:TSP}$	V_{DD} supply current temperature sensing peak	Typical duration = 1.3 ms		19		μA
$\Delta I_{VDD:CK32}$	Additional V_{DD} supply current ⁽⁶⁾	$V_{DD} = 3.0$ V, $F_{CLKOUT} = 32.768$ kHz, $C_L = 10$ pF		1		μA
$\Delta I_{VDD:CK1024}$		$V_{DD} = 3.0$ V, $F_{CLKOUT} = 1024$ Hz, $C_L = 10$ pF		30		nA
$\Delta I_{VDD:CK1}$		$V_{DD} = 3.0$ V, $F_{CLKOUT} = 1$ Hz, $C_L = 10$ pF		0.03		nA
<p>⁽¹⁾ See also V_{DD} Backup and recovery AC Electrical Characteristics and Parameters in section BACKUP AND RECOVERY.</p> <p>⁽²⁾ Clocks operating and RAM and registers retained. Including temperature sensing and compensation.</p> <p>⁽³⁾ CLKOUT is held LOW during power on delay t_{POR1} and is HIGH during the power on reset duration t_{POR2}. Note that between V_{LOW1} (1.2 V) and $V_{DD\text{MIN}}$ (1.5 V), time accuracy specification limits are not guaranteed.</p> <p>⁽⁴⁾ All inputs and outputs are at 0 V or V_{DD}.</p> <p>⁽⁵⁾ 2.2k pull-up resistors on SCL/SDA, excluding external peripherals and pull-up resistor current. All other inputs (besides SDA and SCL) are at 0 V or V_{DD}. Test conditions: Continuous burst read/write, 55h data pattern, 25 μs between each data byte, 20 pF load on each bus pin.</p> <p>⁽⁶⁾ When CLKOUT is enabled (CLKOE is HIGH) the additional V_{DD} supply current ΔI_{VDD} can be calculated as follows: $\Delta I_{VDD} = C_L \times V_{DD} \times f_{OUT}$, e.g. $\Delta I_{VDD} = 10 \text{ pF} \times 3.0 \text{ V} \times 32768 \text{ Hz} = 980 \text{ nA} \approx 1 \mu\text{A}$</p>						

For this Table, $T_A = -40^{\circ}\text{C}$ to $+85^{\circ}\text{C}$ unless otherwise indicated. $V_{DD} = 1.5$ to 5.5 V, $f_{OSC} = 32.768$ kHz, TYP values at 25°C and 3.0 V.

Operating Parameters (continued):

SYMBOL	PARAMETER	CONDITIONS	MIN	TYP	MAX	UNIT
Inputs						
V_{IL}	LOW level input voltage	$V_{DD} = 1.5$ V to 5.5 V			$0.2 V_{DD}$	V
V_{IH}	HIGH level input voltage	Pins: SCL, SDA, CLKOE, EVI	$0.8 V_{DD}$			V
I_{ILEAK}	Input leakage current	$V_{SS} \leq V_i \leq V_{DD}$, $T_A = -40^{\circ}\text{C}$ to $+105^{\circ}\text{C}$	-0.5		0.5	μA
C_I	Input capacitance	$V_{DD} = 3.0$ V, $T_A = 25^{\circ}\text{C}$, $f = 1$ MHz			7	pF
Outputs						
$V_{OH:CLK}$	HIGH level output voltage CLKOUT	$V_{DD} = 1.5$ V, $I_{OH} = 0.1$ mA	1.2			V
		$V_{DD} = 3.0$ V, $I_{OH} = 1.0$ mA	2.5			
		$V_{DD} = 5.0$ V, $I_{OH} = 1.0$ mA	4.5			
$V_{OL:CLK}$	LOW level output voltage CLKOUT	$V_{DD} = 1.5$ V, $I_{OL} = -0.1$ mA			0.2	V
		$V_{DD} = 3.0$ V, $I_{OL} = -1.0$ mA			0.5	
		$V_{DD} = 5.0$ V, $I_{OL} = -1.0$ mA			0.5	
t_{CKH}	CLKOUT enable time ⁽⁷⁾	$F_{CLKOUT} = 32.768$ kHz	0		30.5	μs
t_{CKL}	CLKOUT disable time ⁽⁷⁾				0	μs
V_{OL}	LOW level output voltage Pins: SDA, INT	$V_{DD} = 1.5$ V, $I_{OL} = -2.0$ mA			0.4	V
		$V_{DD} = 3.0$ V, $I_{OL} = -3.0$ mA			0.4	
		$V_{DD} = 5.0$ V, $I_{OL} = -3.0$ mA			0.3	
I_{OLEAK}	Output leakage current	$V_O = V_{DD}$ or V_{SS} , $T_A = -40^{\circ}\text{C}$ to $+105^{\circ}\text{C}$	-0.5		0.5	μA
C_{OUT}	Output capacitance	$V_{DD} = 3.0$ V, $T_A = 25^{\circ}\text{C}$, $f = 1$ MHz			7	pF

⁽⁷⁾ Also refer to section 32.768 KHZ ENABLE/DISABLE TIMING.

7.2.1. TEMPERATURE COMPENSATION AND CURRENT CONSUMPTION

Typical I_{VDD} average current:

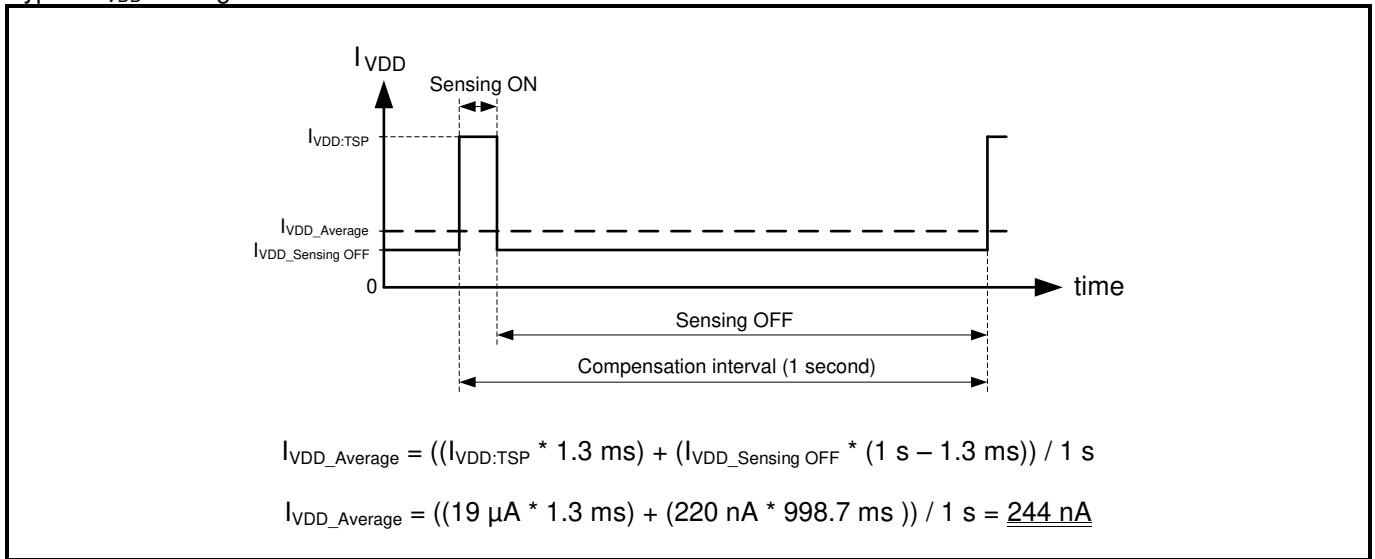

7.2.2. 32.768 KHZ ENABLE/DISABLE TIMING

32.768 kHz CLKOUT enable and disable times. The 32.768 kHz CLKOUT is enabled synchronously and disabled asynchronously:

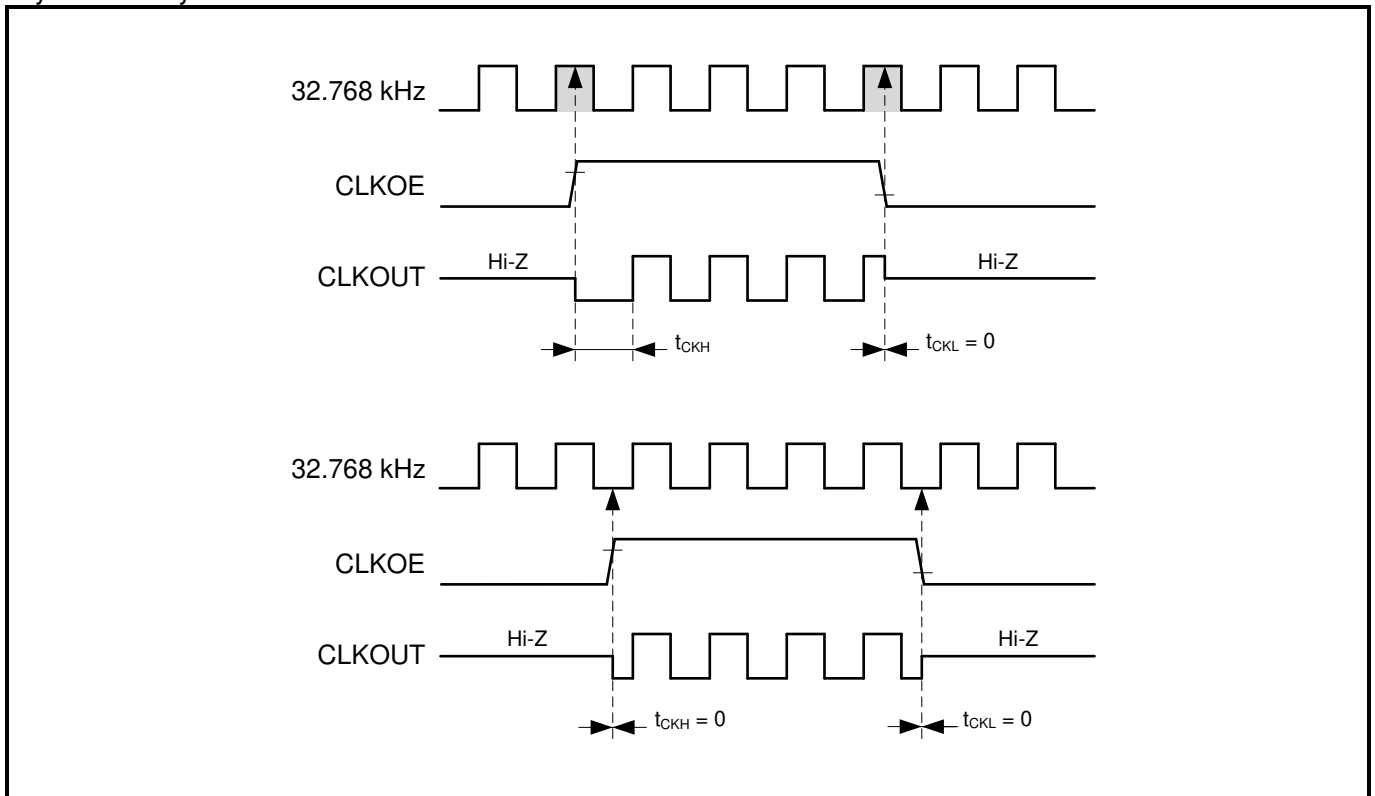

Hint: The other CLKOUT frequencies, 1024 Hz and 1 Hz, are asynchronously enabled and disabled.

7.3. OSCILLATOR PARAMETERS

For this Table, $T_A = -40^{\circ}\text{C}$ to $+85^{\circ}\text{C}$ unless otherwise indicated. $V_{DD} = 1.5$ to 5.5 V, $f_{OSC} = 32.768$ kHz, TYP values at 25°C and 3.0 V.

Oscillator Parameters:

SYMBOL	PARAMETER	CONDITIONS	MIN	TYP	MAX	UNIT
Xtal General						
F	Crystal Frequency			32.768		kHz
t_{START}	Oscillator start-up time $t_{START} = t_{POR1} + t_{POR2}$	CLKOE = V_{DD}		80	500	ms
$t_{START:EXT}$	Oscillator start-up time $t_{START:EXT} = t_{POR1:EXT} + t_{POR2:EXT}$ for extended temperature range	$V_{DD} = 1.6$ to 5.5 V CLKOE = V_{DD} , $T_A = +85^{\circ}\text{C}$ to $+105^{\circ}\text{C}$			500	ms
δ_{CLKOUT}	CLKOUT duty cycle	$F_{CLKOUT} = 32.768$ kHz $T_A = 25^{\circ}\text{C}$		50 \pm 10		%
Xtal Frequency Characteristics						
$\Delta F/F$	Frequency accuracy	$T_A = 25^{\circ}\text{C}$, calibration disabled		± 10	± 20	ppm
$\Delta F/F_{TOPR}$	Frequency vs. temperature characteristics	$T_{OPR} = -40^{\circ}\text{C}$ to $+105^{\circ}\text{C}$ $V_{DD} = 3.0$ V		$-0.035^{ppm}/^{\circ}\text{C}^2 (T_{OPR} - T_0)^2 \pm 10\%$		ppm
T_0	Turnover temperature			$+25 \pm 5$		$^{\circ}\text{C}$
$\Delta F/F$	Aging first year max.	$T_A = 25^{\circ}\text{C}$, $V_{DD} = 3.0$ V			± 3	ppm
Digital Temperature Compensated Xtal DTCXO						
$\Delta F/F$	Time accuracy calibrated, CLKOUT measured on rising edge of One 1 Hz period	$T_A = 0^{\circ}\text{C}$ to $+50^{\circ}\text{C}$		± 1.5		ppm
				± 0.13		s/day
		$T_A = -40^{\circ}\text{C}$ to $+85^{\circ}\text{C}$		± 3		ppm
				± 0.26		s/day
$\Delta F/F$	1 Hz OFFSET value Min. corr. step (LSB) and Max. corr. range	$T_A = -40^{\circ}\text{C}$ to $+105^{\circ}\text{C}$	± 0.2384		± 7.4	ppm

See also TIME ACCURACY VS. TEMPERATURE CHARACTERISTICS.

7.3.1.TIME ACCURACY 1 HZ EXAMPLES

Time accuracy of the temperature compensated 1 Hz signal, TA = -40°C to +85°C:

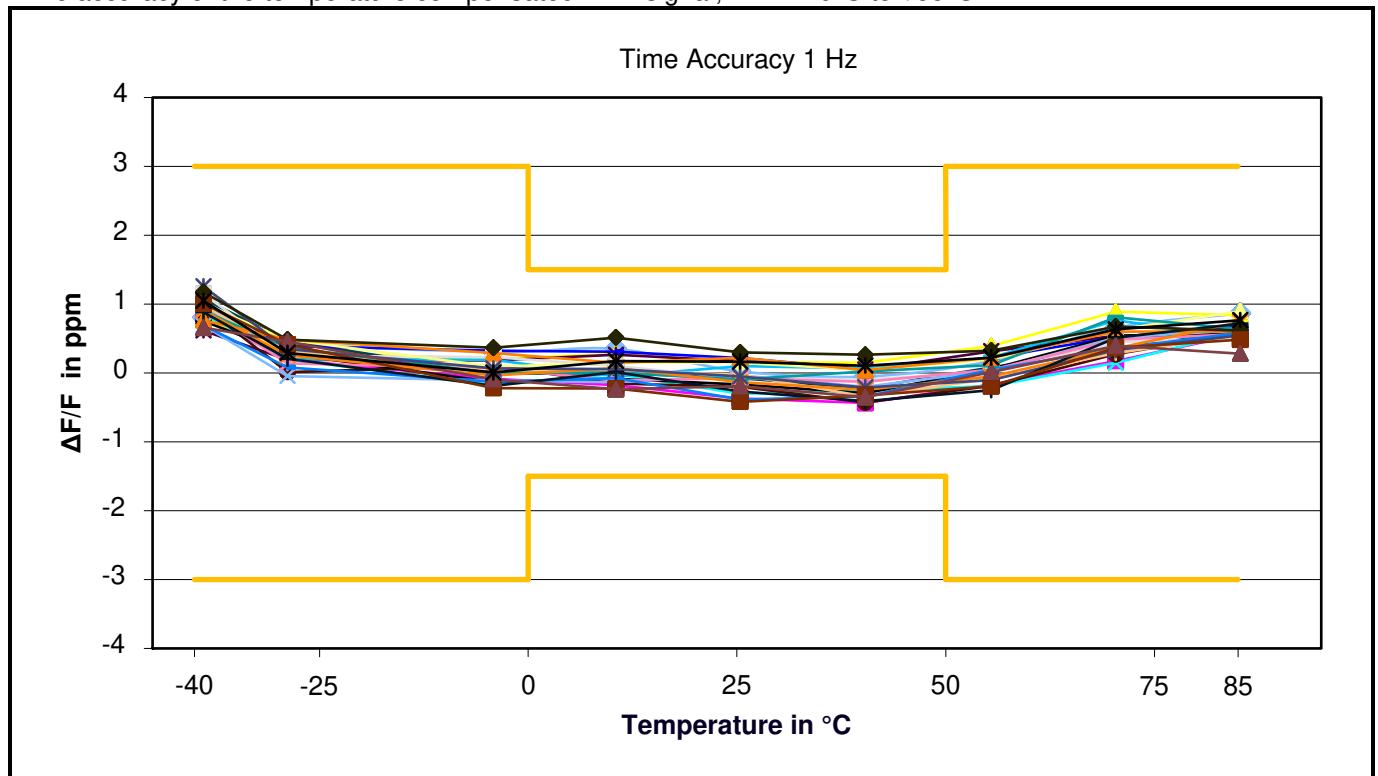

Time accuracy of the temperature compensated 1 Hz signal, including extended range from +85°C to +105°C:

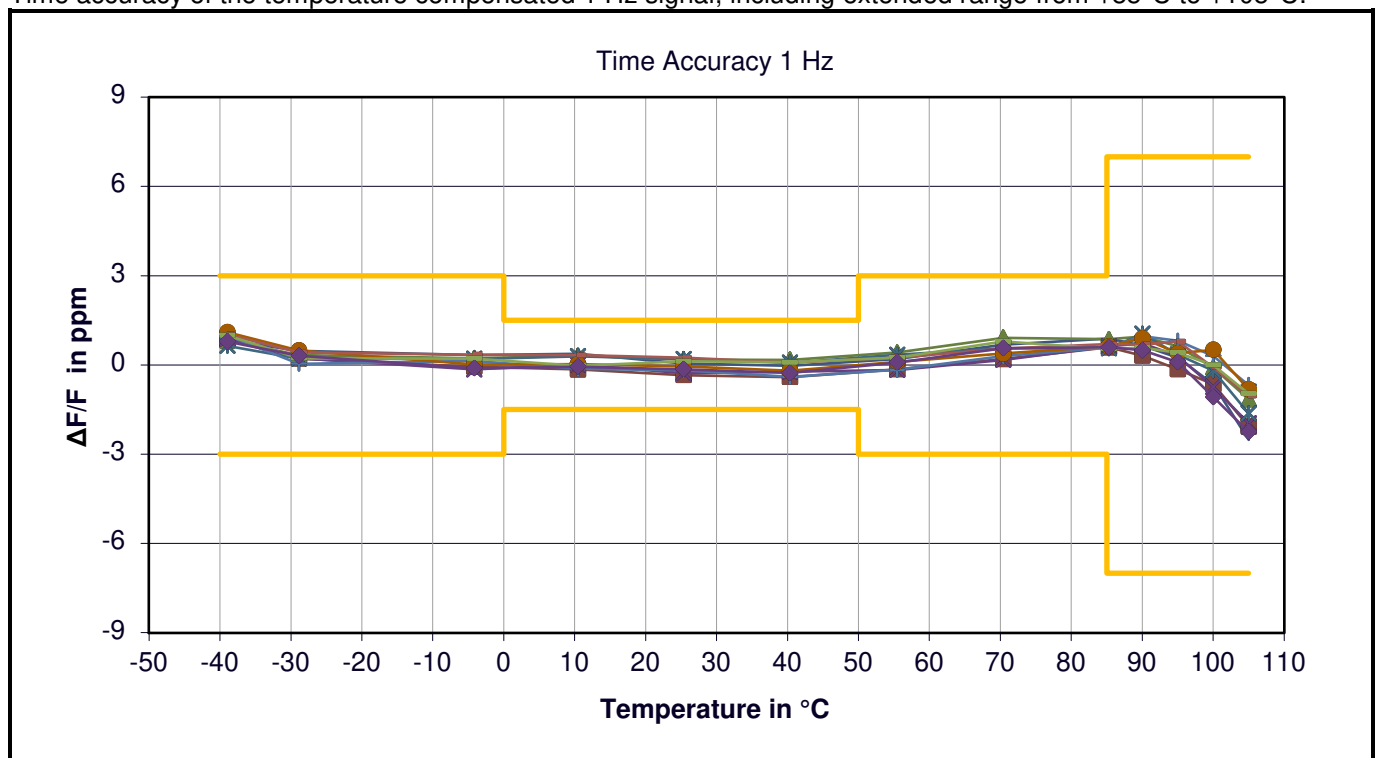

7.4. POWER ON AC ELECTRICAL CHARACTERISTICS

The following Figure and table describe the power on AC electrical characteristics for the CLKOUT pin.

Power On AC Electrical Characteristics:

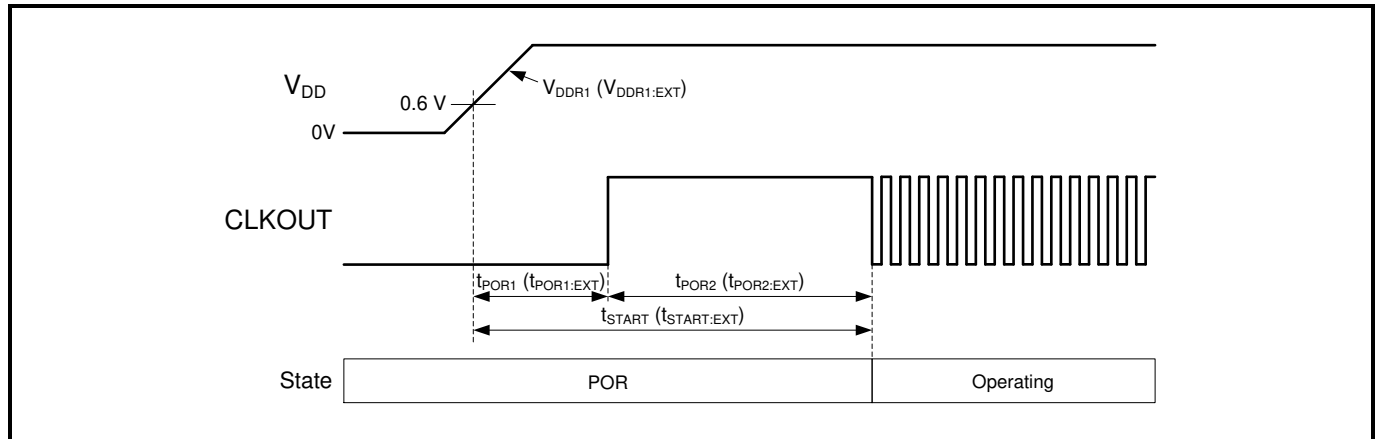

For this Table, $T_A = -40^{\circ}\text{C}$ to $+85^{\circ}\text{C}$ unless otherwise indicated. $V_{DD} = 1.5$ to 5.5 V, TYP values at 25°C and 3.0 V.

Power On AC Electrical Parameters:

SYMBOL	PARAMETER	CONDITIONS	MIN	TYP	MAX	UNIT
V_{DDR1}	V_{DD} rising slew rate at initial power on reset (POR)	CLKOE = V_{DD}	0.1		1	V/ms
t_{POR1}	Power on delay			3	10	ms
t_{POR2}	Power on reset duration				80	500
$V_{DDR1:EXT}$	V_{DD} rising slew rate at initial power on reset (POR) for extended temperature range	$V_{DD} = 1.6$ to 5.5 V, CLKOE = V_{DD} , $T_A = +85^{\circ}\text{C}$ to $+105^{\circ}\text{C}$	0.1		1	V/ms
$t_{POR1:EXT}$	Power on delay for extended temperature range				10	ms
$t_{POR2:EXT}$	Power on reset duration for extended temperature range				500	ms

7.5. BACKUP AND RECOVERY

During a backup event with a backup voltage V_{DD} higher than V_{LOW1} (V_{LOW2}) the CLKOUT function is operating including the Temperature compensation and the RAM and registers are retained. Pay attention to the CLKOUT function if the power supply voltage V_{DD} of the RV-8803-C7 sharply goes up and down, meaning V_{DD} is changing between Main power voltage and Backup capacitor voltage. The CLKOUT signal can then disappear for several milliseconds when the voltage change is to sharp.

1. Choose a valid V_{DD} range for the CLKOUT function. E.g. 1.6 V to 3.6 V (see OPERATING PARAMETERS).
2. Ensure that the slew rates V_{DDF} and V_{DDR2} fulfill their specifications.
3. Check if these required specifications are fulfilled on your system.

The following Figure and Table describe the backup and recovery AC electrical characteristics (valid example with a backup voltage $> V_{LOW1}$ (V_{LOW2})).

V_{DD} Backup and recovery AC Electrical Characteristics:

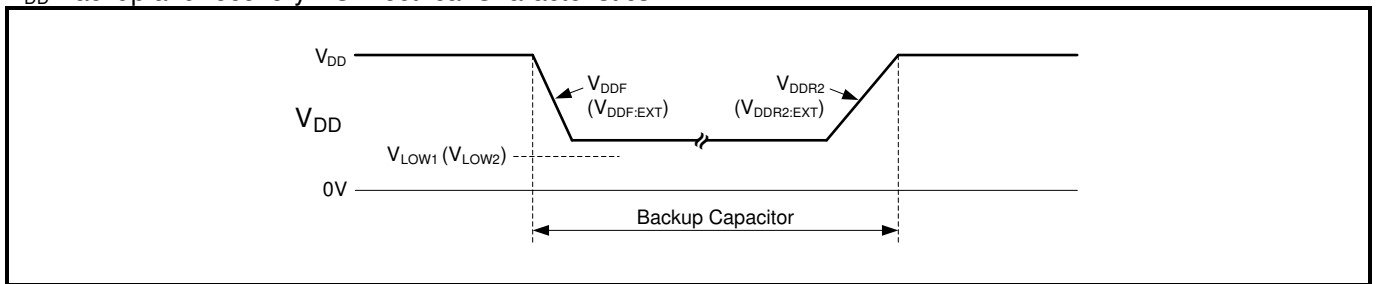

For this Table, $T_A = -40^{\circ}\text{C}$ to $+85^{\circ}\text{C}$ unless otherwise indicated.

V_{DD} Backup and recovery AC Electrical Parameters:

SYMBOL	PARAMETER	CONDITIONS	MIN	TYP	MAX	UNIT
V_{DDF}	V_{DD} falling slew rate				0.5	V/ μs
V_{DDR2}	V_{DD} rising slew rate	Rising from $V_{DD} = 1.5\text{ V}$ to $V_{DD} \leq 3.5\text{ V}$			0.2	V/ μs
		Rising from $V_{DD} = 1.5\text{ V}$ to $V_{DD} > 3.5\text{ V}$			0.07	
$V_{DDF:EXT}$	V_{DD} falling slew rate for extended temperature range	$T_A = +85^{\circ}\text{C}$ to $+105^{\circ}\text{C}$			0.5	V/ μs
$V_{DDR2:EXT}$	V_{DD} rising slew rate for extended temperature range	Rising from $V_{DD} = 1.6\text{ V}$ to $V_{DD} \leq 3.5\text{ V}$ $T_A = +85^{\circ}\text{C}$ to $+105^{\circ}\text{C}$			0.2	V/ μs
		Rising from $V_{DD} = 1.6\text{ V}$ to $V_{DD} > 3.5\text{ V}$ $T_A = +85^{\circ}\text{C}$ to $+105^{\circ}\text{C}$			0.07	

7.6. I²C-BUS CHARACTERISTICS

The following Figure and Table describe the I²C AC electrical parameters.

I²C AC Parameter Definitions:

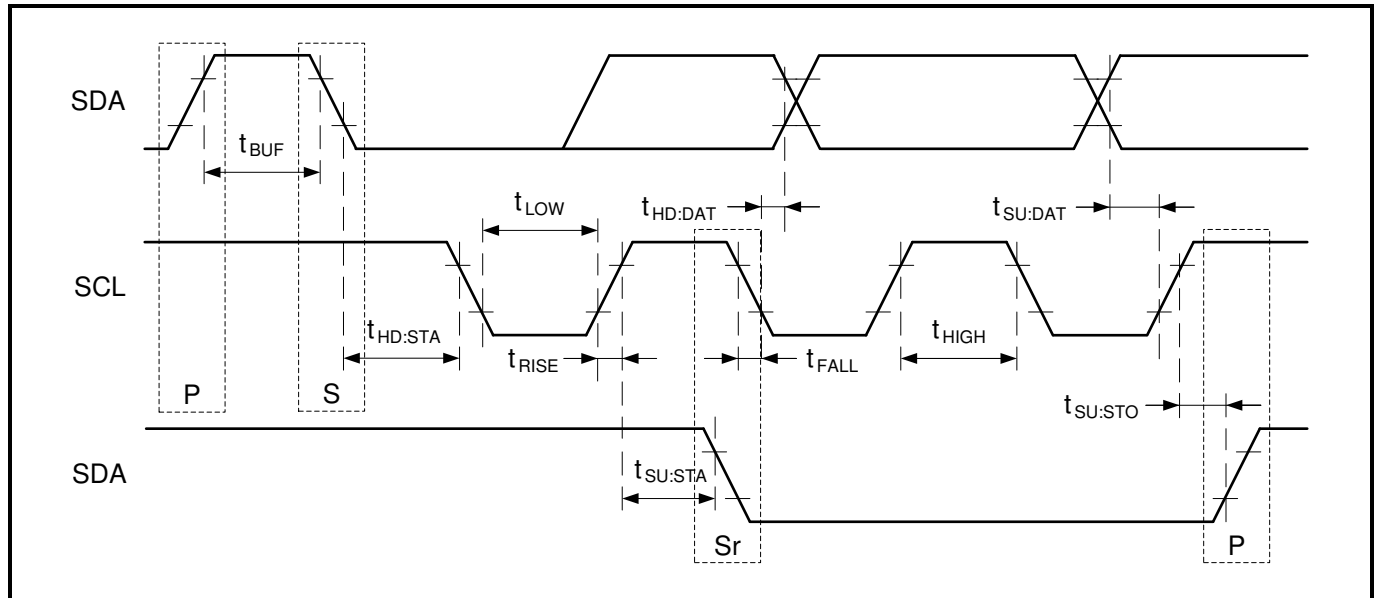

For the following Table, T_A = -40°C to +85°C, TYP values at 25°C.

I²C AC Electrical Parameters:

SYMBOL	PARAMETER	Conditions	MIN	TYP	MAX	UNIT
f _{SCL}	SCL input clock frequency	V _{DD} ≥ 1.5 V	0		100	kHz
		V _{DD} ≥ 2.0 V	0		400	
t _{LOW}	Low period of SCL clock	V _{DD} ≥ 1.5 V	4.7			μs
		V _{DD} ≥ 2.0 V	1.3			
t _{HIGH}	High period of SCL clock	V _{DD} ≥ 1.5 V	4.0			μs
		V _{DD} ≥ 2.0 V	0.6			
t _{RISE}	Rise time of SDA and SCL	V _{DD} ≥ 1.5 V			1000	ns
		V _{DD} ≥ 2.0 V			300	
t _{FALL}	Fall time of SDA and SCL	V _{DD} ≥ 1.5 V			300	ns
		V _{DD} ≥ 2.0 V			300	
t _{HD:STA}	START condition hold time	V _{DD} ≥ 1.5 V	4.0			μs
		V _{DD} ≥ 2.0 V	0.6			
t _{SU:STA}	START condition setup time	V _{DD} ≥ 1.5 V	4.7			μs
		V _{DD} ≥ 2.0 V	0.6			
t _{SU:DAT}	SDA setup time	V _{DD} ≥ 1.5 V	250			ns
		V _{DD} ≥ 2.0 V	100			
t _{HD:DAT}	SDA hold time	V _{DD} ≥ 1.5 V	0			μs
		V _{DD} ≥ 2.0 V	0			
t _{SU:STO}	STOP condition setup time	V _{DD} ≥ 1.5 V	4.0			μs
		V _{DD} ≥ 2.0 V	0.6			
t _{BUF}	Bus free time before a new transmission	V _{DD} ≥ 1.5 V	4.7			μs
		V _{DD} ≥ 2.0 V	1.3			

S = Start condition, Sr = Repeated Start condition, P = Stop condition

I²C-bus access:

For devices with production date code 853 and earlier it is recommended before going to idle mode to complete the I²C-bus access always with a Read Operation followed by the STOP condition (see READ OPERATION).

8. TYPICAL APPLICATION CIRCUIT

8.1. OPERATING RV-8803-C7 WITH BACKUP CAPACITOR

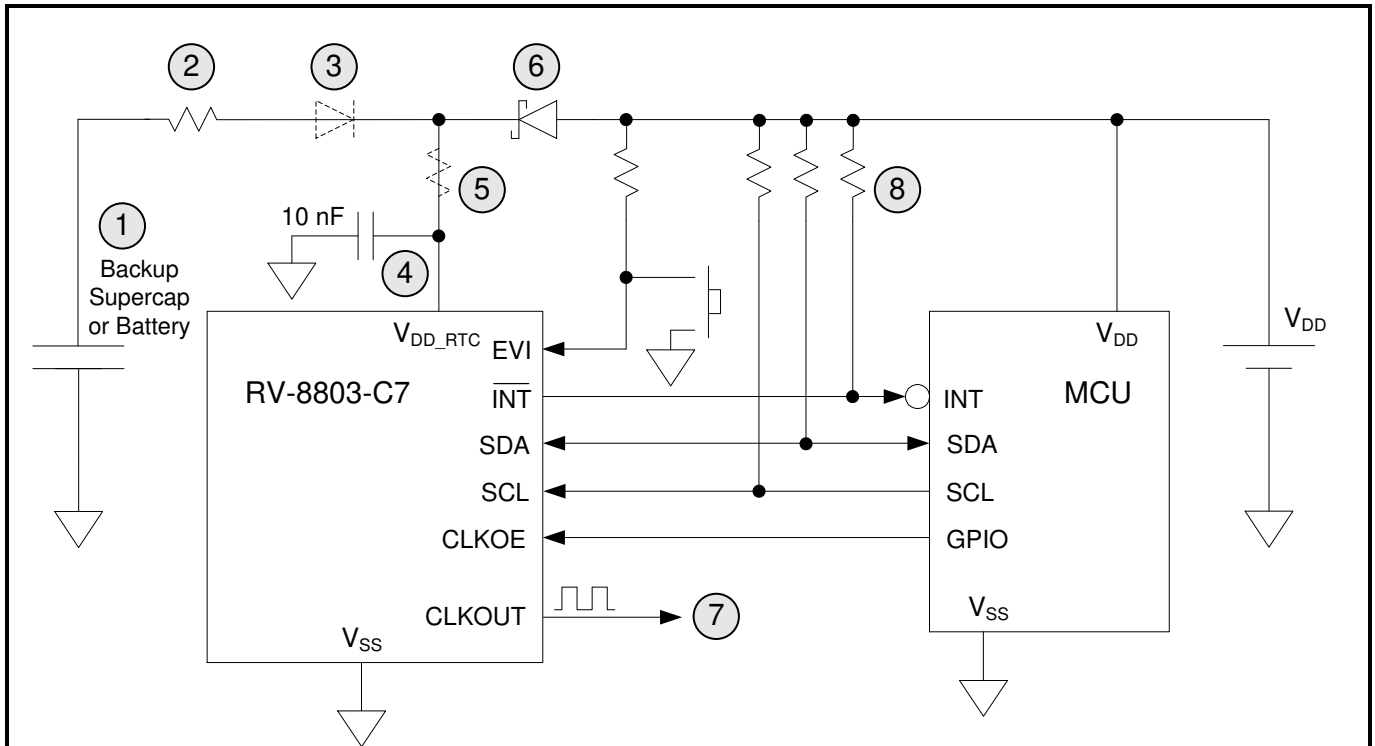

- ① Low-cost MLCC (*) ceramic capacitor, supercapacitor (e.g. 1 farad), primary battery or secondary battery LMR (respect manufacturer specifications for constant charging voltage).
- ② When using a supercapacitor, a resistor is used to limit the inrush current into the supercapacitor at power-on. E.g. to comply with the maximum forward current of the schottky diode.
or
When using a battery, a resistor is used to limit the maximum current in case of a short circuit.
- ③ When using a primary battery, a diode is required.
- ④ A 10 nF to 100 nF decoupling capacitor is recommended close to the device.
- ⑤ A serial resistor might be needed in order not to exceed the maximum slew rates (see BACKUP AND RECOVERY).
- ⑥ Schottky diode. This low V_F diode (less than 0.3 V) is needed to not exceed the specified maximum voltage at the inputs of the RV-8803-C7 when normal supply voltage V_{DD} is present ($V_{I_MAX} = V_{DD_RTC} + 0.3V$). Schottky diodes have considerable leakage currents. To optimize backup time it is recommended to select a low leakage Schottky (e.g. BAS70-05).
- ⑦ CLKOUT offers the selectable frequencies 32.768 kHz (default), 1024 Hz and 1 Hz for application use. If not used, it is recommended to disable CLKOUT for optimized current consumption (tie CLKOE to Ground).
- ⑧ Interface lines SCL, SDA and the \overline{INT} output are open drain and require pull-up resistors to V_{DD} .

(*) Note, that low-cost MLCCs are normally used for short time keeping (minutes) and the more expensive supercapacitors for a longer backup time (day).

9. PACKAGE

9.1. DIMENSIONS AND SOLDER PAD LAYOUT

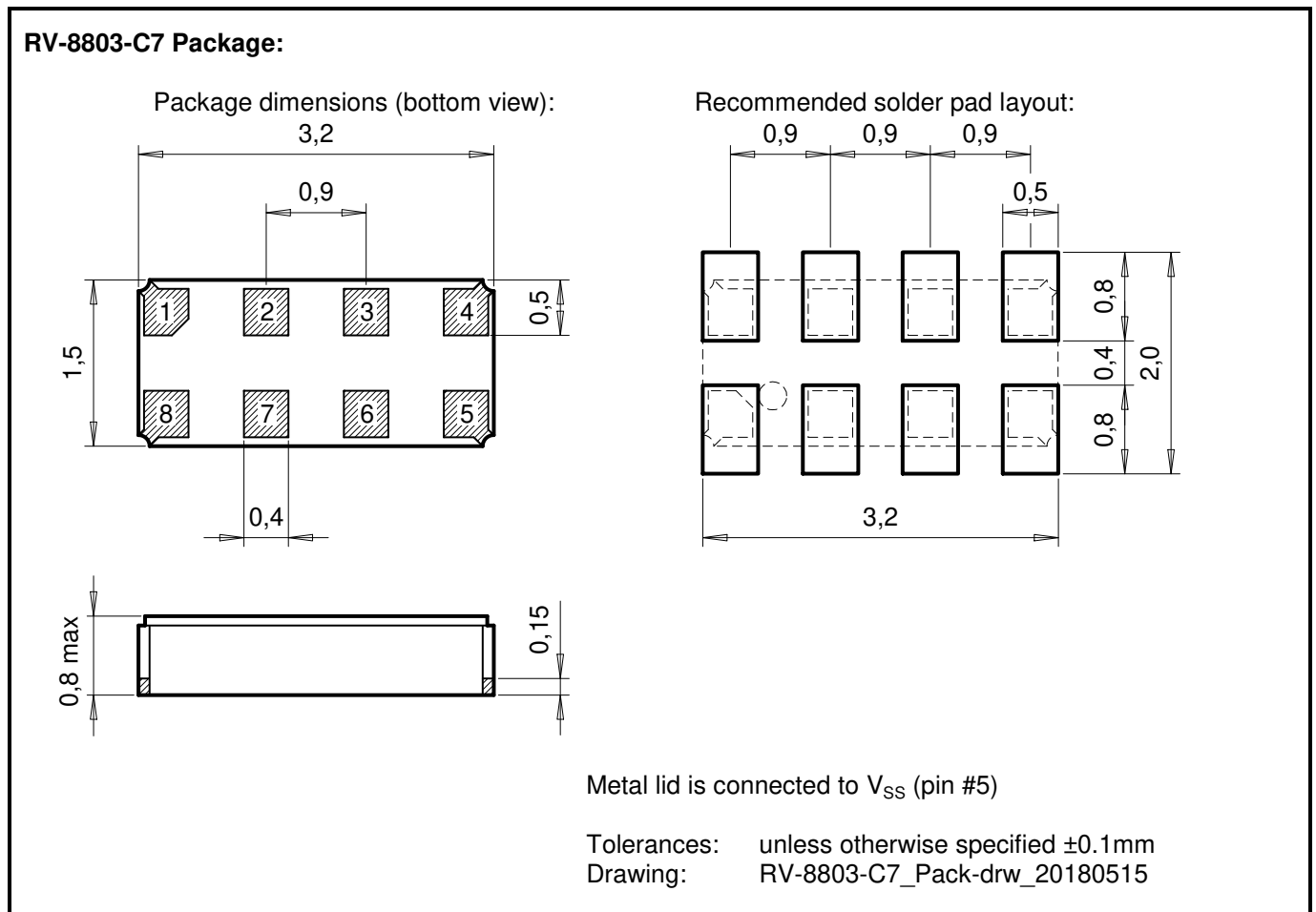

All dimensions in mm typical.

9.1.1. RECOMMENDED THERMAL RELIEF

When connecting a pad to a copper plane, thermal relief is recommended.

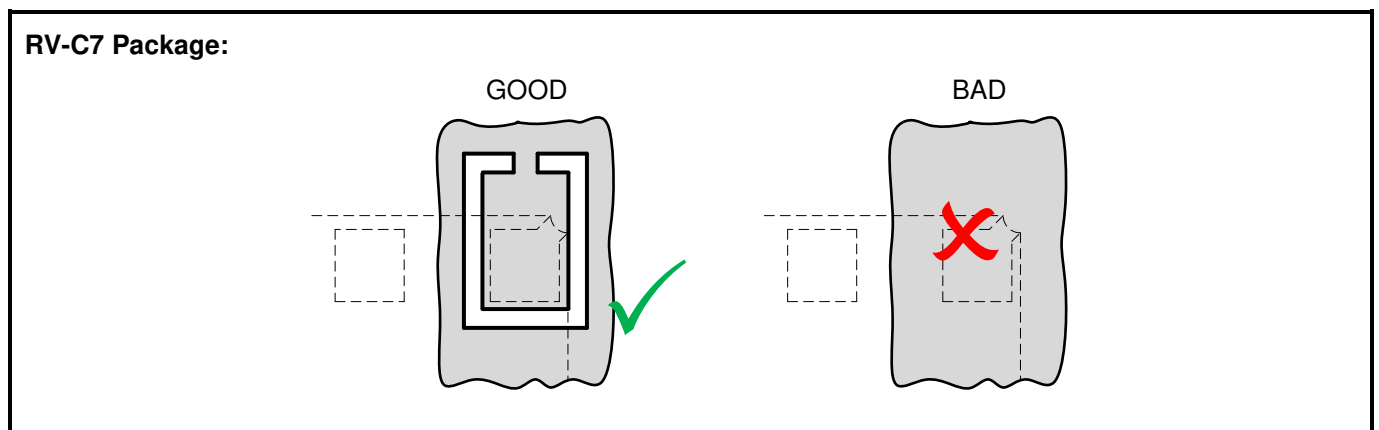

9.2. MARKING AND PIN #1 INDEX

Laser marking RV-8803-C7 Package: (top view)

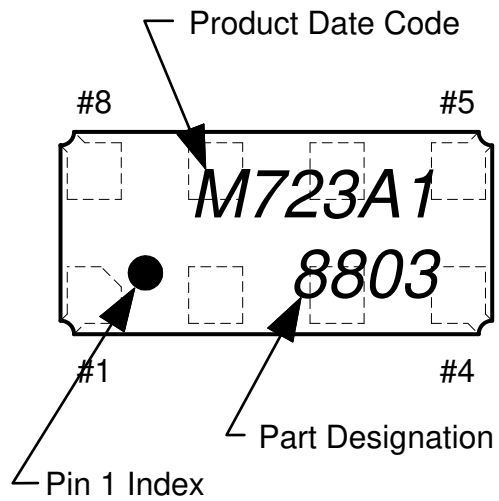

10. MATERIAL COMPOSITION DECLARATION & ENVIRONMENTAL INFORMATION

10.1. HOMOGENOUS MATERIAL COMPOSITION DECLARATION

Homogenous material information according to IPC-1752 standard

Material Composition RV-8803-C7:

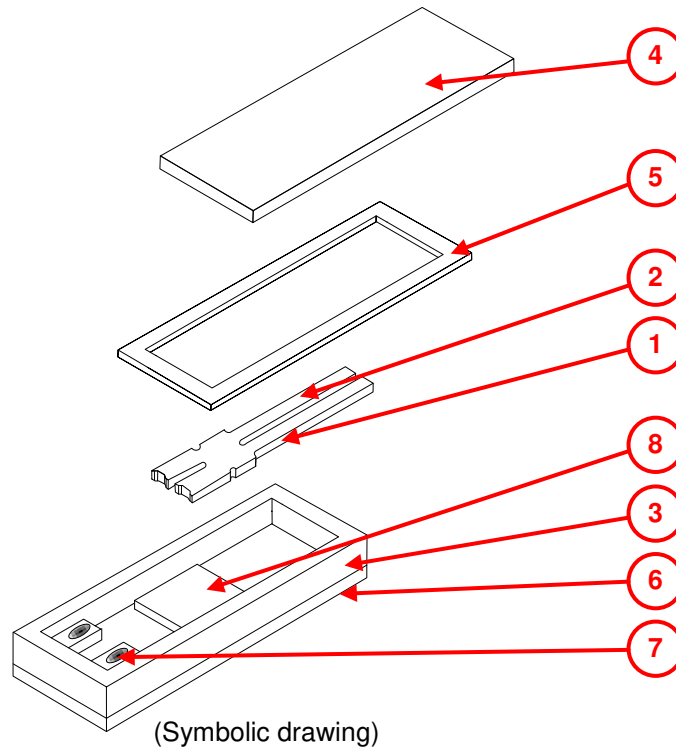

No.	Item Component Name	Sub Item Material Name	Material Weight		Substance Element	CAS Number	Comment
			(mg)	(%)			
1	Resonator	Quartz Crystal	0.13	100%	SiO ₂	14808-60-7	
2	Electrodes	Cr+Au	0.01	6%	Cr	Cr: 7440-47-3	
				94%	Au	Au: 7440-57-5	
3	Housing	Ceramic	6.90	100%	Al ₂ O ₃	1344-28-1	
4	Metal Lid	Kovar Lid	2.67	95%	Fe53Ni29Co18	Fe: 7439-89-6 Ni: 7440-02-0 Co: 7440-48-4	Metal Lid (Kovar)
				4.95%	Ni	Ni: 7440-02-0	Nickel plating
				0.05%	Au	Au: 7440-57-5	Gold plating
5	Seal	Solder Preform	0.54	80%	Au80 / Sn20	Au: 7440-57-5	
				20%		Sn: 7440-31-5	
6	Terminations	Internal and external terminals	0.38	80%	Mo	Mo: 7439-98-7	Molybdenum
				15%	Ni	Ni: 7440-02-0	Nickel plating
				5%	Au 0.5 micron	Au: 7440-57-5	Gold plating
7	Conductive adhesive	Silver filled Silicone glue	0.09	88%	Ag	Ag: 7440-22-4	
				12%	Siloxanes and silicones	68083-19-2	di-Me, vinyl group-terminated
				0%	Distillates, petroleum hydrotreated	64742-47-8	Does not appear in finished product
8	CMOS IC	Silicon Gold bumps	0.64	90%	Si	Si: 7440-21-3	
				10%	Au	Au: 7440-57-5	
Unit weight			11.4				

10.2. MATERIAL ANALYSIS & TEST RESULTS

Homogenous material information according to IPC-1752 standard

No.	Item Component Name	Sub Item Material Name	RoHS						Halogen				Phthalates				
			Pb	Cd	Hg	Cr+6	PBB	PBDE	F	Cl	Br	I	BBP	DBP	DEHP	DINP	
1	Resonator	Quartz Crystal	nd	nd	nd	nd	nd	nd	nd	nd	nd	nd	nd	nd	nd	nd	nd
2	Electrodes	Cr+Au	nd	nd	nd	nd	nd	nd	nd	nd	nd	nd	nd	nd	nd	nd	nd
3	Housing	Ceramic	nd	nd	nd	nd	nd	nd	nd	nd	nd	nd	nd	nd	nd	nd	nd
4	Metal Lid	Kovar Lid & Plating	nd	nd	nd	nd	nd	nd	nd	nd	nd	nd	nd	nd	nd	nd	nd
5	Seal	Solder Preform	nd	nd	nd	nd	nd	nd	nd	nd	nd	nd	nd	nd	nd	nd	nd
6	Terminations	Int. & ext. terminals	nd	nd	nd	nd	nd	nd	nd	nd	nd	nd	nd	nd	nd	nd	nd
7	Conductive adhesive	Silver filled Silicone glue	nd	nd	nd	nd	nd	nd	nd	nd	nd	nd	nd	nd	nd	nd	nd
8	CMOS IC	Silicon & Gold bumps	nd	nd	nd	nd	nd	nd	nd	nd	nd	nd	nd	nd	nd	nd	nd
	MDL	Measurement Detection Limit	2 ppm				5 ppm		50 ppm				0.003%		0.01%		

nd = not detectable

Test methods:**RoHS**

Test method with reference to IEC 62321-5: 2013

MDL: 2 ppm (PBB / PBDE: 5 ppm)

Halogen

Test method with reference to BS EN 14582:2007

MDL: 50 ppm

Phthalates

Test method with reference to EN 14372

MDL: 0.003 % (DINP 0.01%)

10.3. RECYCLING MATERIAL INFORMATION

Recycling material information according to IPC-1752 standard.

Element weight is accumulated and referenced to the unit weight of 11.4 mg.

Item Material Name	No.	Item Component Name	Material Weight		Substance Element	CAS Number	Comment
			(mg)	(%)			
Quartz Crystal	1	Resonator	0.13	1.14	SiO ₂	14808-60-7	
Chromium	2	Electrodes	0.0006	0.005	Cr	Cr: 7440-47-3	
Ceramic	3	Housing	6.90	60.74	Al ₂ O ₃	1344-28-1	
Gold	2 4 5 6 8	Electrodes Metal Lid Seal Terminations CMOS IC	0.53	4.63	Au	Au: 7440-57-5	
Tin	5	Seal	0.11	0.95	Sn	Sn: 7440-31-5	
Nickel	4 6	Metal Lid Terminations	0.19	1.67	Ni	Ni: 7440-02-0	
Molybdenum	6	Terminations	0.3	2.68	Mo	Mo: 7439-98-7	
Kovar	4	Metal Lid	2.53	22.33	Fe53Ni29Co18	Fe: 7439-89-6 Ni: 7440-02-0 Co: 7440-48-4	
Silver	7a	Conductive adhesive	0.079	0.7	Ag	Ag: 7440-22-4	
Siloxanes and silicones	7b	Conductive adhesive	0.011	0.10	Siloxanes and silicones	68083-19-2	di-Me, vinyl group-terminated
Distillates	7c	Conductive adhesive	0	0	Distillates	64742-47-8	hydrotreated petroleum, does not appear in finished products
Silicon	8	CMOS IC	0.58	5.07	Si	Si: 7440-21-3	
Unit weight (total)			11.4	100			

10.4. ENVIRONMENTAL PROPERTIES & ABSOLUTE MAXIMUM RATINGS

Package	Description
SON-8	Small Outline Non-leaded (SON), ceramic package with metal lid

Parameter	Directive	Conditions	Value
Product weight (total)			11.4 mg
Storage temperature		Store as bare product	-55 to +125°C
Moisture sensitivity level (MSL)	IPC/JEDEC J-STD-020D		MSL1
FIT / MTBF			available on request

Terminal finish:

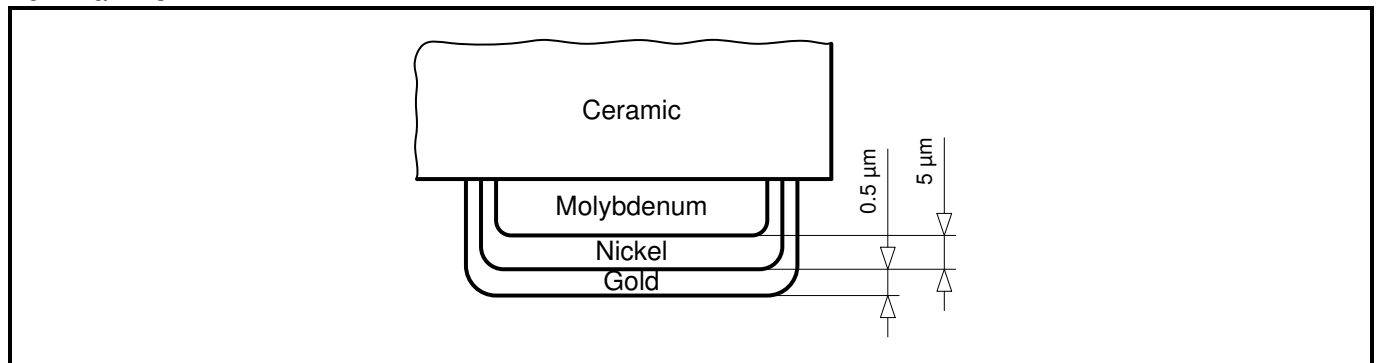

11. SOLDERING INFORMATION

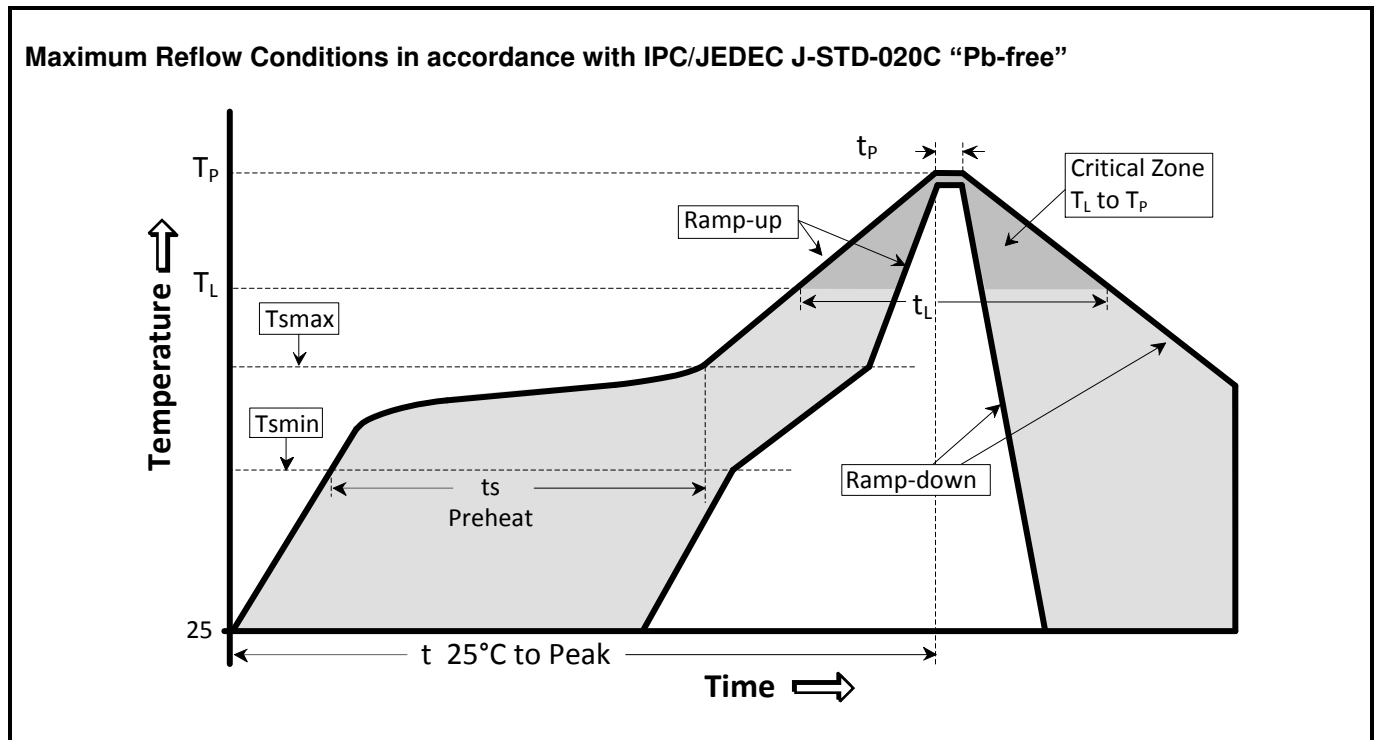

Temperature Profile	Symbol	Condition	Unit
Average ramp-up rate	$(T_{smax} \text{ to } T_p)$	3°C / second max	°C / s
Ramp down Rate	T_{cool}	6°C / second max	°C / s
Time 25°C to Peak Temperature	$T_{to-peak}$	8 minutes max	min
Preheat			
Temperature min	T_{smin}	150	°C
Temperature max	T_{smax}	200	°C
Time T_{smin} to T_{smax}	t_s	60 – 180	sec
Soldering above liquidus			
Temperature liquidus	T_L	217	°C
Time above liquidus	t_L	60 – 150	sec
Peak temperature			
Peak Temperature	T_p	260	°C
Time within 5°C of peak temperature	t_p	20 – 40	sec

12. HANDLING PRECAUTIONS FOR MODULES WITH EMBEDDED CRYSTALS

The built-in tuning-fork crystal consists of pure Silicon Dioxide in crystalline form. The cavity inside the package is evacuated and hermetically sealed in order for the crystal blank to function undisturbed from air molecules, humidity and other influences.

Shock and vibration:

Keep the crystal / module from being exposed to **excessive mechanical shock and vibration**. Micro Crystal guarantees that the crystal / module will bear a mechanical shock of 5000 g / 0.3 ms.

The following special situations may generate either shock or vibration:

Multiple PCB panels - Usually at the end of the pick & place process the single PCBs are cut out with a router. These machines sometimes generate vibrations on the PCB that have a fundamental or harmonic frequency close to 32.768 kHz. This might cause breakage of crystal blanks due to resonance. Router speed should be adjusted to avoid resonant vibration.

Ultrasonic cleaning - Avoid cleaning processes using ultrasonic energy. These processes can damage crystals due to mechanical resonance of the crystal blank.

Overheating, rework high temperature exposure:

Avoid overheating the package. The package is sealed with a seal ring consisting of 80% Gold and 20% Tin. The eutectic melting temperature of this alloy is at 280°C. Heating the seal ring up to >280°C will cause melting of the metal seal which then, due to the vacuum, is sucked into the cavity forming an air duct. This happens when using hot-air-gun set at temperatures >300°C.

Use the following methods for rework:

- Use a hot-air- gun set at 270°C.
- Use 2 temperature controlled soldering irons, set at 270°C, with special-tips to contact all solder-joints from both sides of the package at the same time, remove part with tweezers when pad solder is liquid.

14. COMPLIANCE INFORMATION

Micro Crystal confirms that the standard product Real-Time Clock Module RV-8803-C7 is compliant with “EU RoHS Directive” and “EU REACH Directives”.

Please find the actual Certificate of Conformance for Environmental Regulations on our website:

[CoC Environment RV-Series.pdf](#)

15. DOCUMENT REVISION HISTORY

Date	Revision #	Revision Details
January 2015	1.0	First release
April 2016	1.1	Added additional terms and specifications. Corrected drawings. Updated text.
May 2016	1.2	Updated detailed explanation about I ² C timeout function, 7.6
October 2017	1.3	Added Ordering Information, 1.3. Added Interrupt Output, 4.4. Added First Period Duration, 4.5.3. Complemented External Event Function, 4.8. Added CLKOUT Frequency Selection, 4.9. Complemented Time Data Read-Out, 4.12. Added RESET Bit Function, 4.13. Added ERST Bit Function, 4.14. Added Free-Clocking I ² C-Bus, 6.10. Complemented Operating Parameters, 7.2. Added 32.768 kHz Enable/Disable Timing, 7.2.2. Removed Detailed explanation about I ² C timeout function, 7.6. Added Explanation about I ² C-bus access, 7.6. Complemented Operating RV-8803-C7 With Backup Capacitor, 8.1. Added Recommended Thermal Relief, 9.1.1. Added Material Composition Declaration & Environmental Information, 10. Updated Packing & Shipping Information, 13. Added Compliance Information, 14.
June 2018	1.4	Added extended temperature range specifications, +85°C to 105°C. Added “Metal lid is connected to V _{SS} (pin #5)”, 9.1. Corrected small text errors.
February 2019	1.5	Corrected Periodic time update interrupt function, 3.8., 4.4., 4.6. and 5.7.1. Adapted Explanation about I ² C-bus access, 7.6.
May 2019	1.6	Changed field name X to RESERVED, 3.1. and 3.8. Corrected POR values for Time and Calendar Registers to XX, 3.2., 3.3. and 3.11. Complemented V1F Flag description, 3.7. and 7.2.

Information furnished is believed to be accurate and reliable. However, Micro Crystal assumes no responsibility for the consequences of use of such information nor for any infringement of patents or other rights of third parties which may result from its use. In accordance with our policy of continuous development and improvement, Micro Crystal reserves the right to modify specifications mentioned in this publication without prior notice. This product is not authorized for use as critical component in life support devices or systems.



Micro Crystal AG
Muehlestrasse 14
CH-2540 Grenchen
Switzerland

Phone +41 32 655 82 82
Fax +41 32 655 82 83
sales@microcrystal.com
www.microcrystal.com