

AZ DISPLAYS, INC.

COMPLETE LCD SOLUTIONS

SPECIFICATIONS FOR LIQUID CRYSTAL DISPLAY

PART NUMBER:

AGM 1232G SERIES

DATE:

APRIL 26, 2001

AGM1232G SERIES GRAPHIC MODULE

1.0 MECHANICAL SPECS

1. Item	Description
2. Overall Module Size	84.0mm(W) x 44.0mm(H) x max 13.0mm(D) for LED backlight version 84.0mm(W) x 44.0mm(H) x max 9.0mm(D) for reflective version
3. Dot Size	0.40mm(W) x 0.45mm(H)
4. Dot Pitch	0.44mm(W) x 0.49mm(H)
5. Duty	1/32
6. Controller IC	SED1520FOA/DOA
7. LC Fluid Options	STN, FSTN
8. Polarizer Options	Reflective, Transflective, Transmissive
9. Backlight Options	LED
10. Temperature Range Options	Standard (0°C ~ 50°C), Wide (-20°C ~ 70°C)

2.0 ABSOLUTE MAXIMUM RATINGS

Item	Symbol	Min	Typ	Max	Unit
Operating temperature (Standard)	Top	0	-	50	°C
Storage temperature (Standard)	Tst	-20	-	70	°C
Operating temperature (Wide temperature)	Top	-20	-	70	°C
Storage temperature (Wide temperature)	Tst	-30	-	80	°C
Input voltage	Vin	Vss		Vdd	V
Supply voltage for logic	Vdd- Vss	-0.3	-	7.0	V
Supply voltage for LCD drive	Vdd- Vo	5.0	6.5	9.5	V

AGM1232G SERIES GRAPHIC MODULE

3.0 ELECTRICAL CHARACTERISTICS

Item	Symbol	Condition	Min	Typ	Max	Unit
Input voltage (high)	Vih	H level	3.5	-	Vdd	V
Input voltage (low)	Vil	L level	0	-	1.5	V
Recommended LC Driving Voltage (Standard Temp)	Vdd - Vo	0°C	-	7.8	10.0	V
		25°C	-	6.5	-	
		50°C	4.3	5.5	-	
Recommended LC Driving Voltage (Wide Temp)	Vdd -Vo	-20°C	-	8.5	10.8	V
		0°C	-	7.8	-	
		50°C	4.3	5.5	-	
		70°C	3.5	4.8	-	
Power Supply Current	Idd	Vdd=5.0V	-	-	13.0	mA
LED Power Supply Voltage	Vfled	R=6.8Ω	-	4.4	5.0	V
LED Power Supply Current	Ifled	R=6.8Ω	-	300	420	mA

AGM1232G SERIES GRAPHIC MODULE

4.0 OPTICAL CHARACTERISTICS

Mode		Item		Cr (Contrast Ratio)		θ (Viewing Angle)		ϕ (Viewing Angle)	
				25°C		25°C		25°C	
		MIN.	TYP.	MIN	TYP.	MIN	TYP.		
R	A	2.8	3.05	80°	85°	-	35°		
	B	7.10	7.70	80°	85°	-	35°		
	C	-	-	-	-	-	-		
S	A	2.49	2.99	80°	85°	-	35°		
	B	7.05	7.55	80°	85°	-	35°		
	C	-	-	-	-	-	-		

Note:

- R: Reflective
- S: Transflective
- A: STN Gray
- B: STN Yellow
- C: FSTN

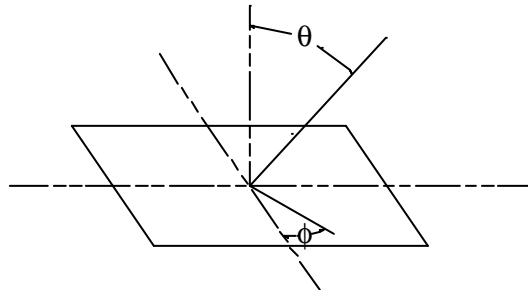

At: $\phi = 0^\circ$, $\theta = 0^\circ$

Item	Symbol	Condition	Min	Typ	Max	Unit
Response time (rise)	Tr	25°C	-	80	160	ms
Response time (fall)	Tf	25°C	-	50	100	ms

AGM1232G SERIES GRAPHIC MODULE

5.0 BLOCK DIAGRAM

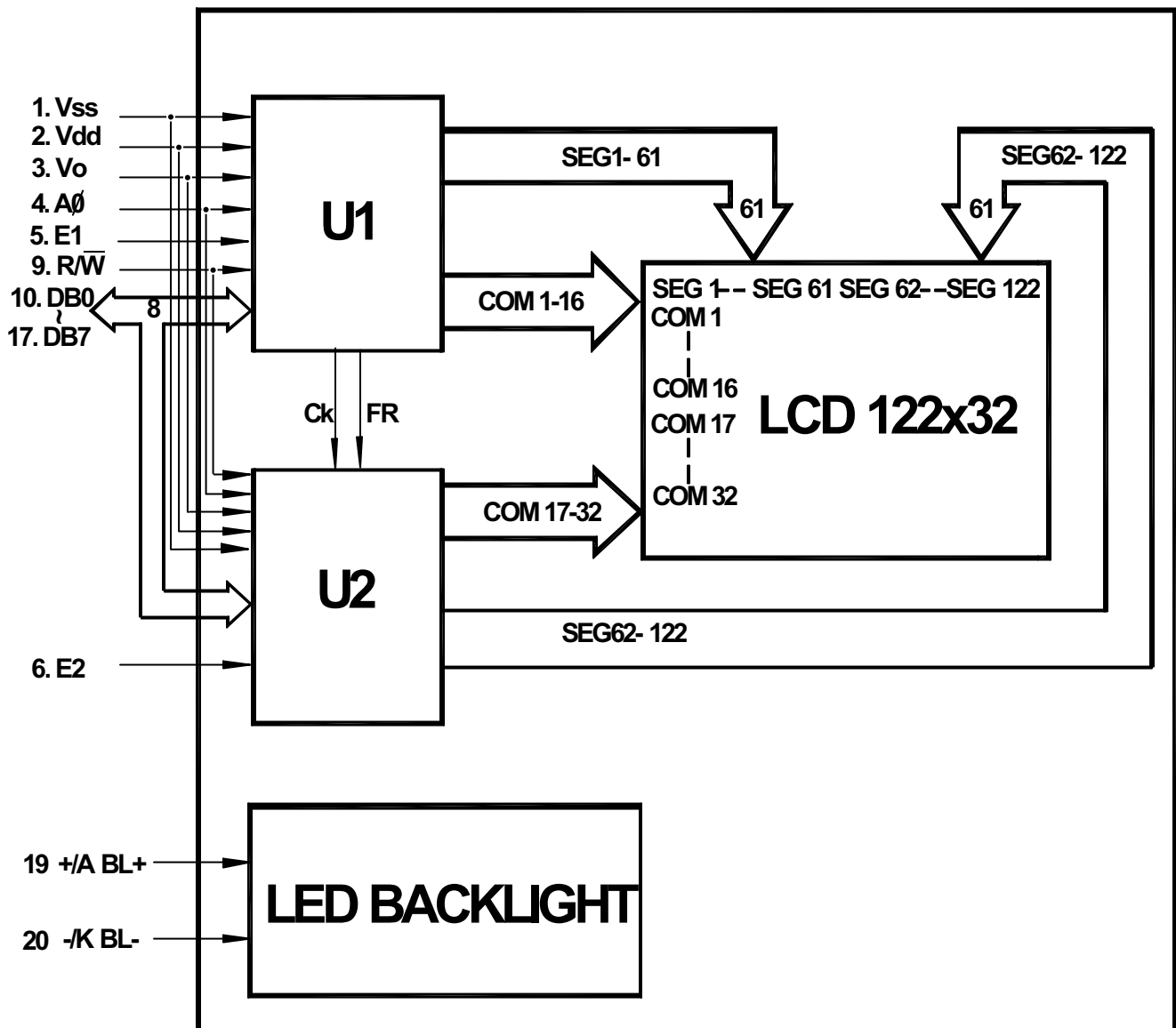

AGM1232G SERIES GRAPHIC MODULE

6.0 PIN ASSIGNMENT

Pin No.	Symbol	Function	Level
1	Vss	Ground	-
2	Vdd	Power Supply For Logic Circuit	-
3	Vo	Power Supply For LCD Driving	-
4	A \emptyset	Instruction/Data	H/L
5	E1	Enable for IC1	H/L
6	E2	Enable for IC2	H/L
7	NC		
8	NC		
9	R/ \overline{W}	H: Data read L: Data write	H/L
10	DB0	Data bit 0	H/L
11	DB1	Data bit 1	H/L
12	DB2	Data bit 2	H/L
13	DB3	Data bit 3	H/L
14	DB4	Data bit 4	H/L
15	DB5	Data bit 5	H/L
16	DB6	Data bit 6	H/L
17	DB7	Data bit 7	H/L
18	\overline{RES}	Display Reset on active "Low"	H/L
19	BL-	Power Supply for BL+	-
20	BL+	Power Supply for BL-	-

AGM1232G SERIES GRAPHIC MODULE

7.0 POWER SUPPLY

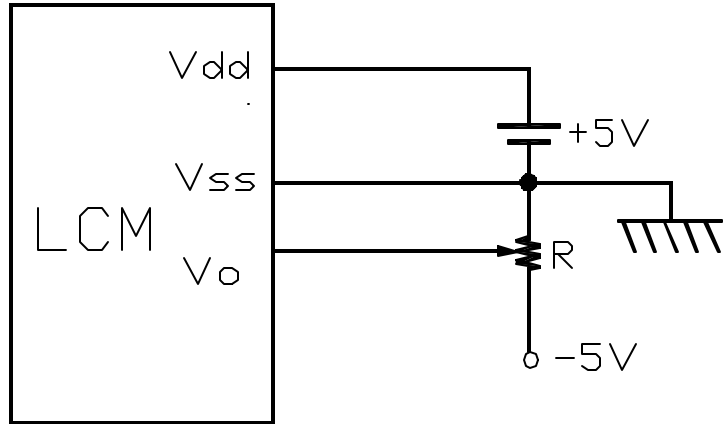

8.0 TIMING CHARACTERISTICS

Item	Symbol	Test Condition	Min.	Typ.	Max.	Unit
System cycle time	t_{CYC6}	Fig. a, Fig. b	1000	-	-	ns
Address setup time	t_{AW6}	Fig. a, Fig. b	20	-	-	ns
Address hold time	t_{AH6}	Fig. a, Fig. b	10	-	-	ns
Data hold time	t_{DH6}	Fig. a	10	-	-	ns
Data setup time	t_{DS6}	Fig. a	80	-	-	ns
Output disable time	t_{OH6}	CL=100 pF	10	-	60	ns
Access time	t_{ACC6}		-	-	90	
Enable pulse width	Read	T_{EW}	100			
	Write		80			
Rise and fall time	T_r, T_f	Fig. a, Fig. b	-	-	15	ns

AGM1232G SERIES GRAPHIC MODULE

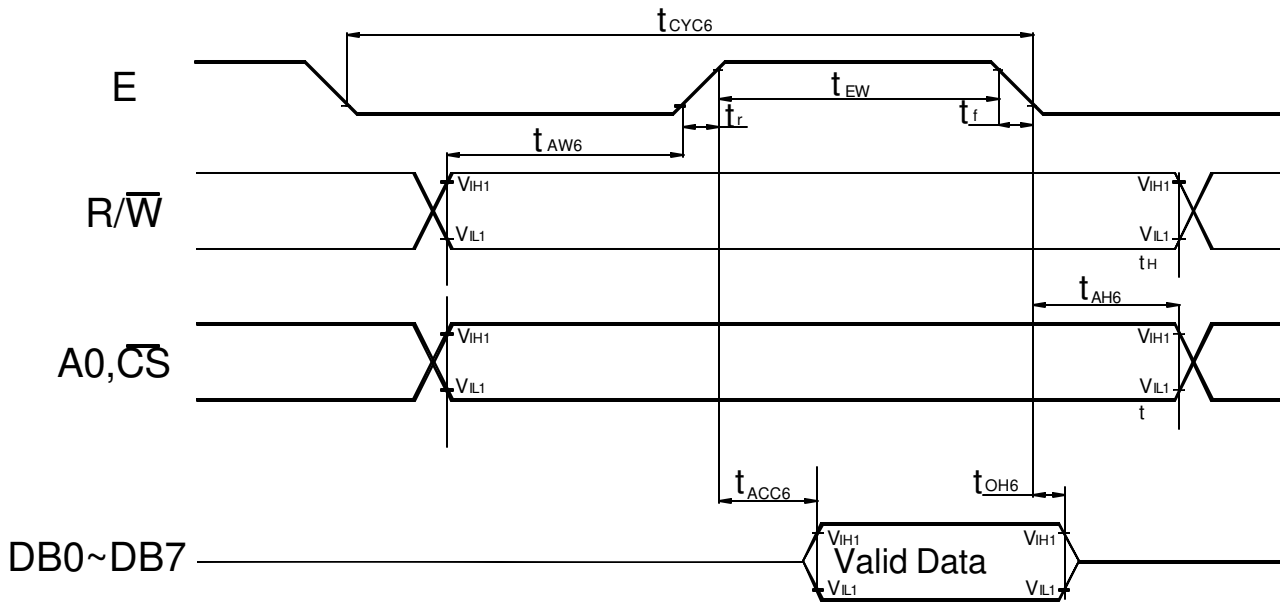

Fig. a Interface timing (data Read)

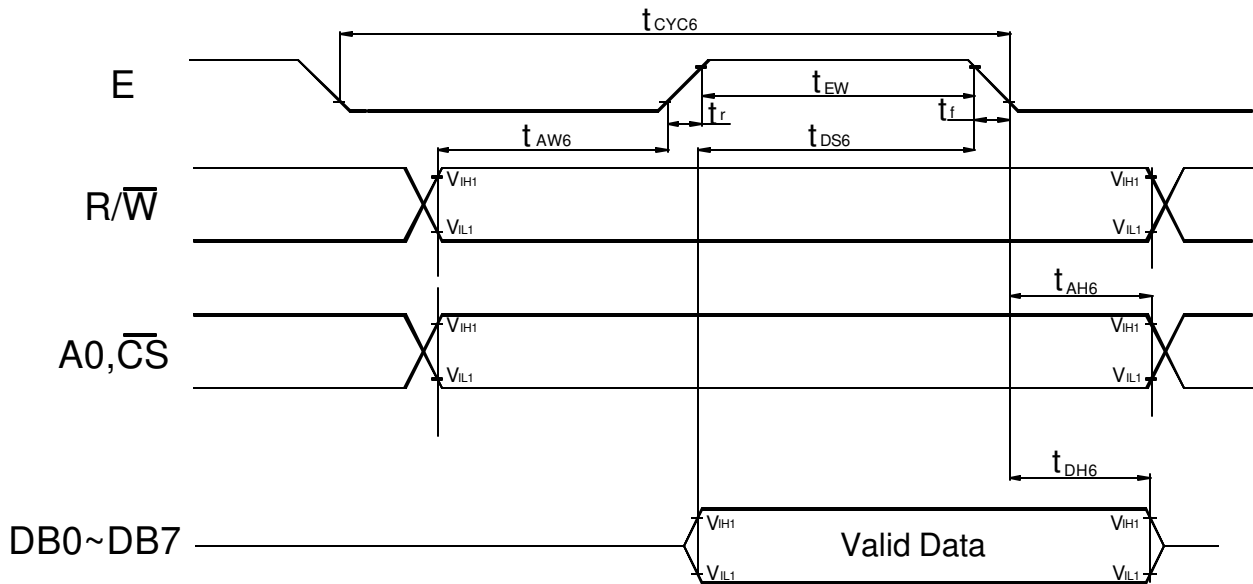

Fig. b Interface timing (data Write)

AGM1232G SERIES GRAPHIC MODULE

9.0 RELIABILITY TEST

Storage Condition	Content	Evaluations and Assessment*			
		Current Consumption	Oozing	Contrast	Other Appearances
Operation at high temperature and humidity	40° C,90% RH,240hrs	Twice initial value or less	none	More than 80% of initial value	No abnormality
High temperature storage	60° C, 240hrs	Twice initial value or less	none	More than 80% of initial value	No abnormality
Low temperature storage	-20° C, 240hrs	Twice initial value or less		More than 80% of initial value	No abnormality

*Evaluations and assessment to be made two hours after returning to room temperature (25° C±5° C).

*The LCDs subjected to the test must not have dew condensation.

AGM1232G SERIES GRAPHIC MODULE

10.0 MECHANICAL DIAGRAM

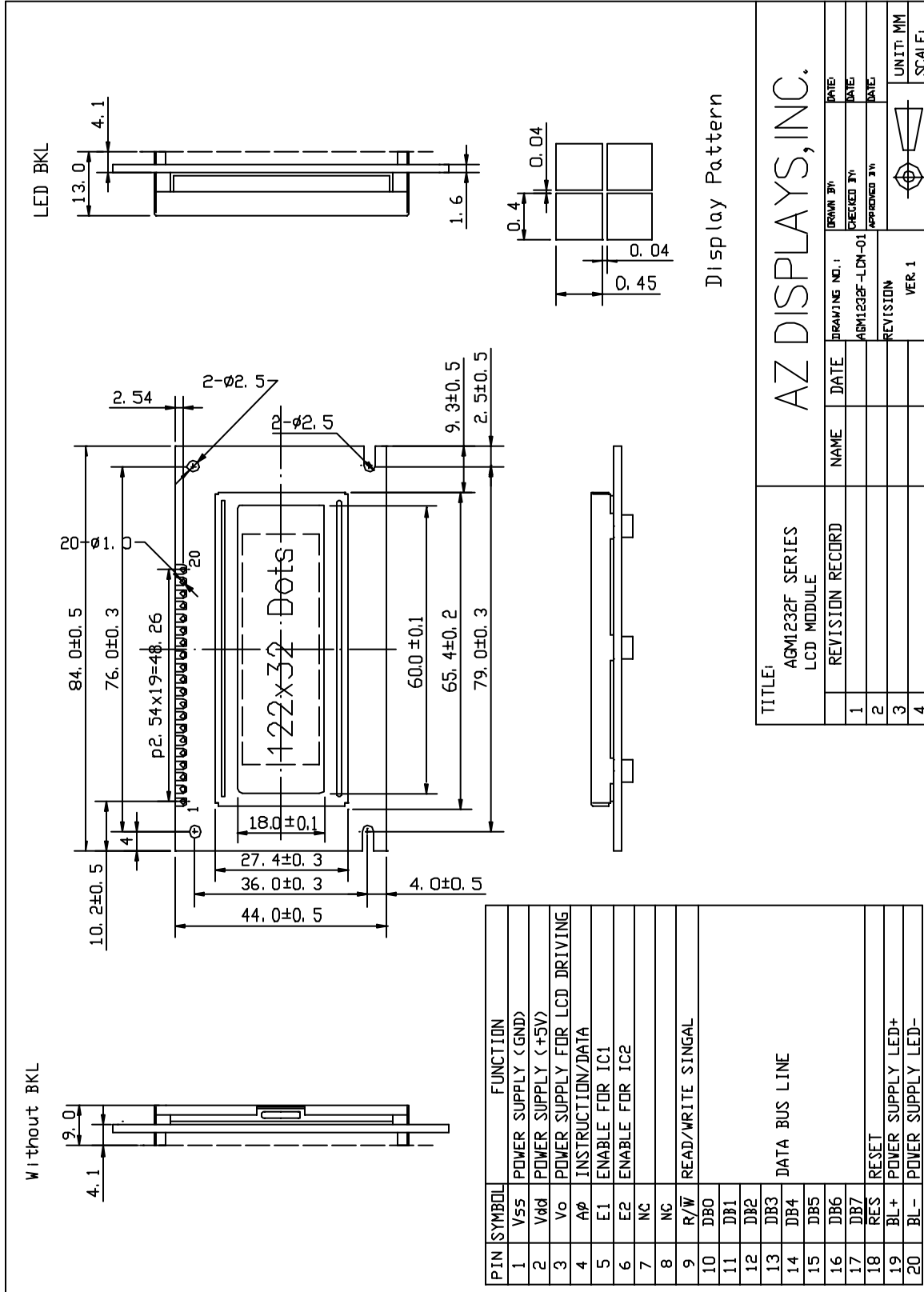

AGM1232G SERIES GRAPHIC MODULE

11.0 RELATION BETWEEN DISPLAY PATTERN AND DRIVERS

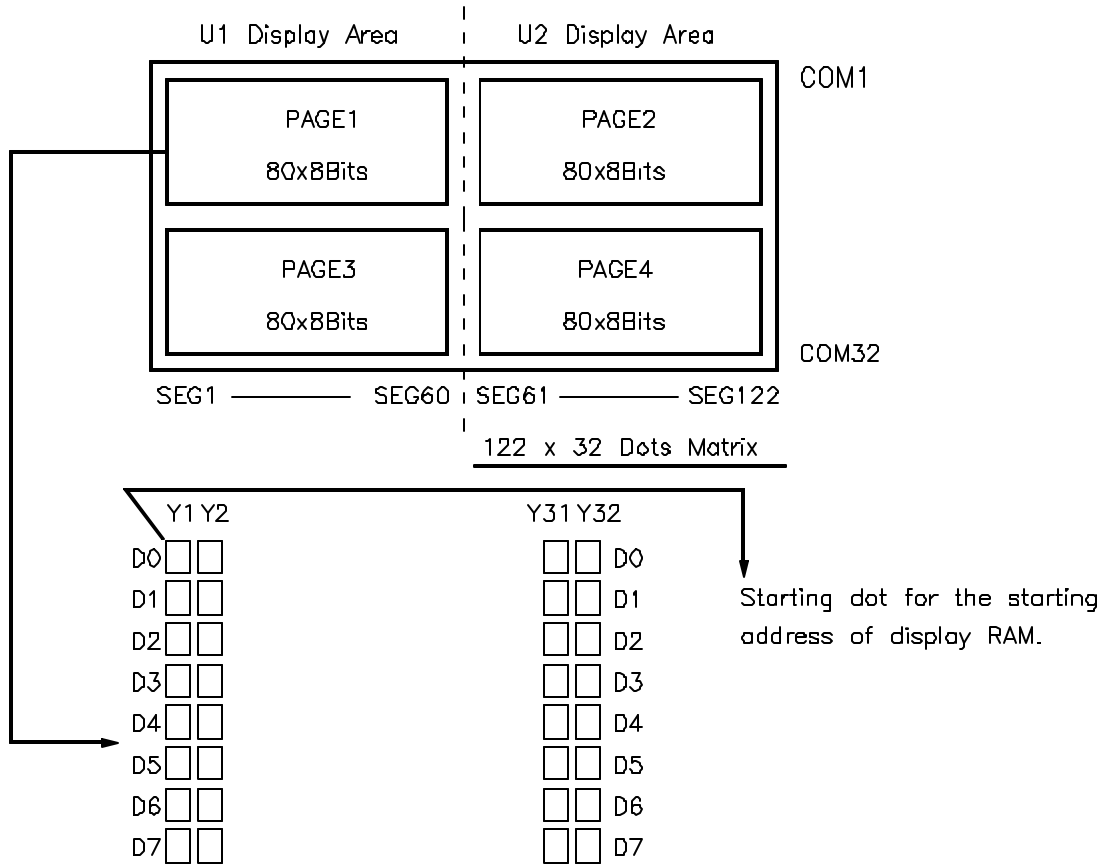

Each segment driver has 4 pages RAM, and each page has 80x8 bits RAM. D0~D7 are 8 bits transmitted data, where D0 is LSB and D7 is MSB.

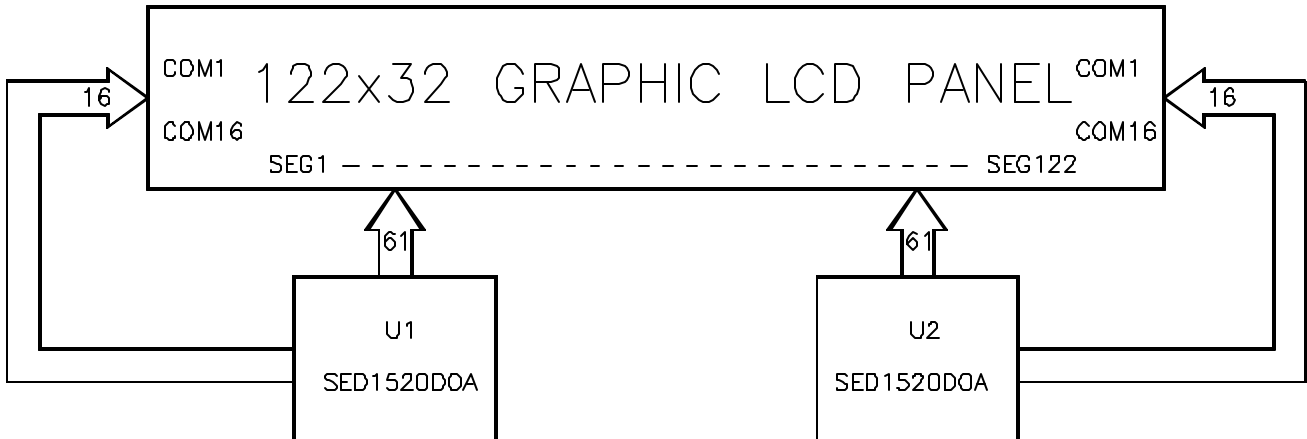

AGM1232G SERIES GRAPHIC MODULE

12.0 DISPLAY CONTROL INSTRUCTION

The display control instructions control the internal state of the SED1520DOA/FOA. Instructions are received from MPU to SED1520DOA/FOA for the display control.

INSTRUCTION	A0	R/W	DB7	DB6	DB5	DB4	DB3	DB2	DB1	DB0	DESCRIPTION	
Display ON/OFF	0	0	1	0	1	0	1	1	1	1/0	Turns display on or off. 0: OFF. 1:ON	
Set Page Address	0	0	1	0	1	1	1	0	Page (0~3)		Sets display RAM Page in Page address register	
Set Column (Segment address)	0	0	0	Column address (0~79)								Sets display RAM column address in column address register
Display Start Line	0	0	1	1	0	Display start line (0~31)					Indicates the display data RAM displayed at the top of the screen.	
Status Read	0	1	BUSY	ADC	ON/OFF	RESET	0	0	0	0	Reads the following status: BUSY 0: Ready 1: Busy ADC 1: CW output 0: CCW output ON/OFF 0: Display on 1: Display off RESET 0: Normal 1: Being Reset	
Write Display Data	1	0	Write Data								Writes data DB0~DB7 from bus into display data RAM.	
Read Display Data	1	1	Read Data								Reads data DB0~DB7 from display data RAM onto the data bus.	
Select ADC	0	0	1	0	1	0	0	0	0	0/1	0: CW output, 1: CCW output	
Static drive ON/OFF	0	0	1	0	1	0	0	1	0	0/1	1: Static drive, 0: Normal driving	
Select duty	0	0	1	0	1	0	1	0	0	0/1	Select LCD duty cycle 1:1/32, 0: 1/16	
Read-Modify-Write	0	0	1	1	1	0	0	0	0	0	Read-Modify-write ON	
END	0	0	1	1	1	0	1	1	1	0	Read-Modify-write OFF	
Reset	0	0	1	1	1	0	0	0	1	0	Software reset	