

# FAN7585

## Intelligent Voltage Mode PWM IC

### Features

- Complete PWM Control and House Keeping Circuitry
- Few External Components
- Precision Voltage Reference Trimmed to 2%
- Dual Output for Push-Pull Operation
- Each Output TR for 200mA Sink Current
- Variable Duty Cycle by Dead Time Control
- Soft Start Capability by Using Dead Time Control
- Double Pulse Suppression Logic
- Over Voltage Protection for 3.3V/5V/12V
- Under Voltage Protection for 3.3V/5V/12V
- Over Current Protection for 3.3V/5V/12V
- One More External Input for Various Protection (PT)
- Remote On/Off Control Function (PS-ON)
- Latch Function Controlled by Remote and Protection Input
- Power Good Signal Generator with Hysteresis

### Typical Application

- PC Power Supply

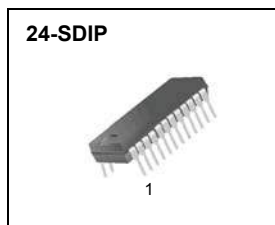

### Description

The FAN7585 is a fixed frequency improved performance pulse width modulation control circuit with complete house-keeping circuitry for use in the secondary side of SMPS (Switched Mode Power Supply). It contains various functions, which are overvoltage protection, undervoltage protection, over current protection, remote on/off control, power good signal generator, etc.

#### OVP (Over Voltage Protection) Section

It has OVP functions for +3.3V, +5V, +12V outputs and PT. The circuit is made up of a comparator with four detecting inputs and without hysteresis voltage. Especially, PT (Pin19) is prepared for an extra OVP input or another protection signal.

#### UVP (Under Voltage Protection) Section

It also has UVP functions for +3.3V, +5V, +12V outputs. The block is made up of a comparator with three detecting inputs and without hysteresis voltage.

#### OCP (Over Current Protection) Section

It has precision OCP functions for +3.3V, +5V, +12V outputs. The block is made up of three comparators with current source setting function. Two inputs of each OCP comparator are connected to both sides of current sensing inductor that is located in the secondary output of SMPS.

#### Remote On/Off Section

The remote on/off section is used to control SMPS externally. If a high signal or open state is supplied to the remote on/off input, PWM signal becomes a high state and all secondary outputs are grounded. The remote on/off signal is transferred with some on-delay and off-delay time of 8ms, 24ms respectively.

#### Precision Reference Section

The reference voltage is trimmed to  $\pm 2\%$ .  
( $4.9V \leq V_{ref} \leq 5.1V$ )

#### PG (Power Good Signal Generator) Section

The power good signal generator is to monitor the voltage level of power supply for safe operation of a microprocessor having some delay time at turn-on. The power good output should be low state before the output voltage is out of regulation at turn-off.

# Internal Block Diagram

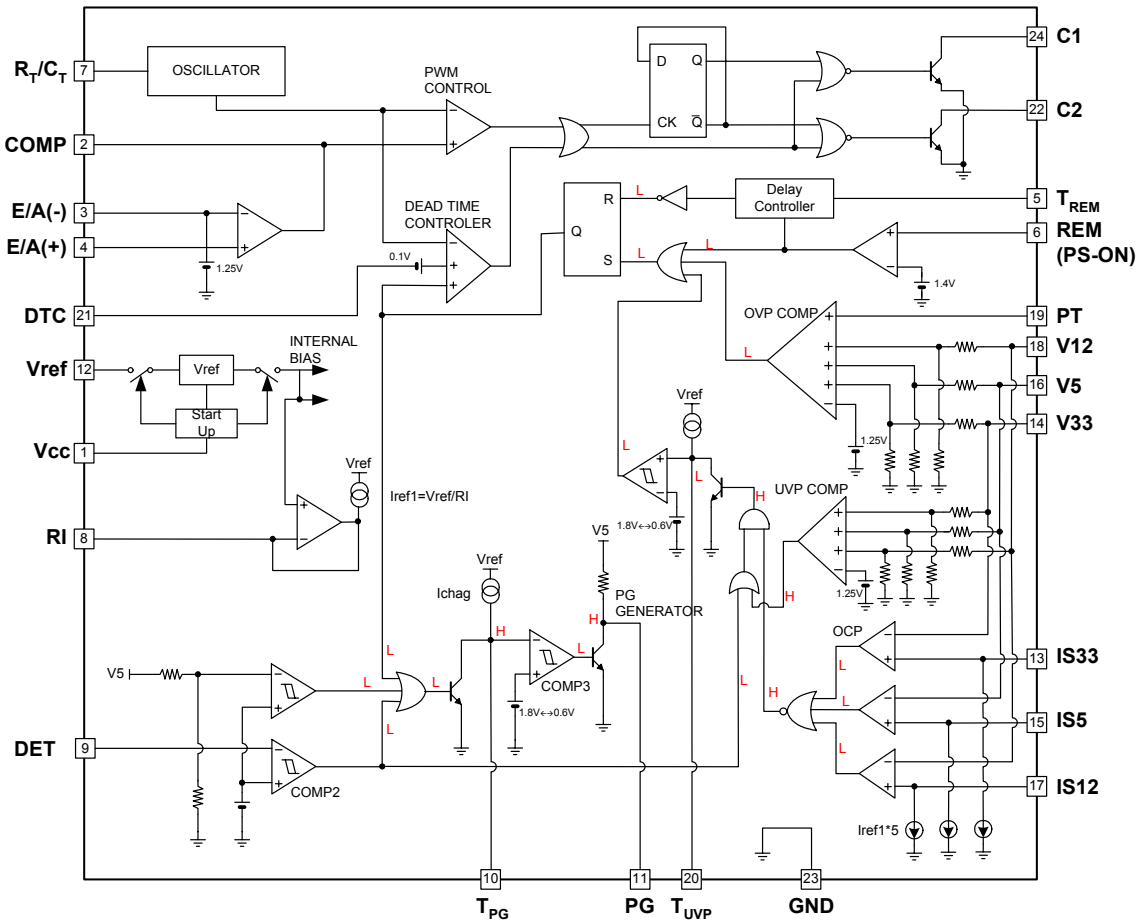

## Pin Definition

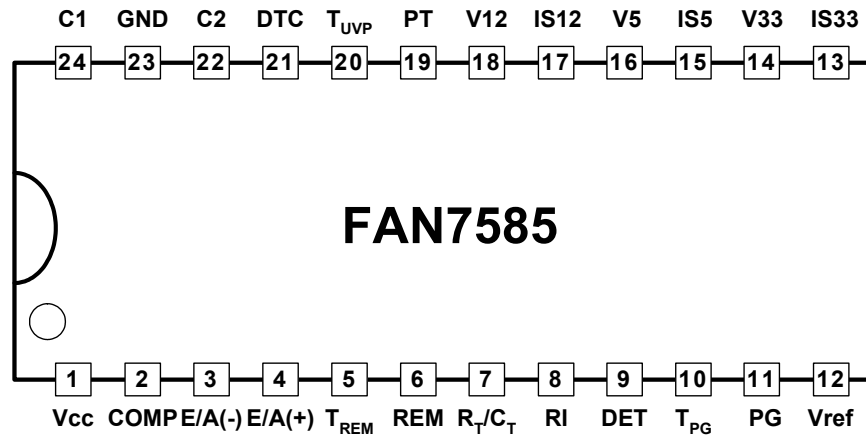

## Pin Description

| Pin Number | Pin Name | I/O | Pin Function Description      | Pin Number | Pin Name         | I/O | Pin Function Description |
|------------|----------|-----|-------------------------------|------------|------------------|-----|--------------------------|
| 1          | VCC      | I   | Supply Voltage                | 13         | IS33             | I   | OCP Input for +3.3V      |
| 2          | COMP     | O   | E/A Output                    | 14         | V33              | I   | OVP, UVP Input for +3.3V |
| 3          | E/A(-)   | I   | E/A (-) Input                 | 15         | IS5              | I   | OCP Input for +5V        |
| 4          | E/A(+)   | I   | E/A (+) Input                 | 16         | V5               | I   | OVP, UVP Input for 5V    |
| 5          | TREM     | -   | Remote On/Off Delay           | 17         | IS12             | I   | OCP Input for +12V       |
| 6          | REM      | I   | Remote On/Off Input           | 18         | V12              | I   | OVP, UVP Input for +12V  |
| 7          | RT/CT    | -   | Oscillation Freq. Setting R,C | 19         | PT               | I   | Extra Protection Input   |
| 8          | RI       | -   | OCP Current Setting R         | 20         | T <sub>UVP</sub> | -   | UVP Delay                |
| 9          | DET      | I   | Detect Input                  | 21         | DTC              | I   | Deadtime Control Input   |
| 10         | TPG      | -   | PG Delay                      | 22         | C2               | O   | Output 2                 |
| 11         | PG       | O   | Power Good Signal Output      | 23         | GND              | -   | Ground                   |
| 12         | Vref     | O   | Precision Reference Voltage   | 24         | C1               | O   | Output 1                 |

## Pin Function

| Pin Number | Pin Name | Pin Function Description   |
|------------|----------|--|
| 1          | VCC      | Supply voltage. Operating range is 15V~30V. Test condition : VCC=20V, Ta=25°C.   |
| 2          | COMP     | Error amplifier output. It is connected to non-inverting input of pulse width modulator comparator.  |
| 3          | E/A(-)   | Error amplifier inverting input. Its reference voltage is always 1.25V.  |
| 4          | E/A(+)   | Error amplifier non-inverting input feedback voltage. This pin may be used to sense power supply output voltages.  |
| 5          | TREM     | Remote On/Off delay. Ton/Toff=8ms/24ms (Typ.) with C=0.1uF. Its High/Low threshold voltages are 1.8V/0.6V.   |
| 6          | REM      | Remote On/Off input. It is TTL operation and its threshold voltage is 1.4V. Voltage at this pin can reach normal 4.6V, with absolute maximum voltage, 5.25V. If REM = "Low", PWM = "Low", that means the main SMPS is operational. when REM = "High", then PWM = "High" and the main SMPS is turned-off.   |
| 7          | RT/CT    | Oscillation frequency setting R, C.(Test condition RT =10kΩ)   |
| 8          | RI       | OCP current setting pin. You can fix the OCP reference current (Iref1) by using RI resistor.   |
| 9          | DET      | AC input under voltage detection pin. Its threshold voltage is 1.25V Typ.  |
| 10         | TPG      | PG delay. Td =260ms (Typ.) with CTPG = 2.2uF. The High/Low threshold voltages are 1.8V/0.6V and the voltage of Pin10 is clamped to 2.9V for noise margin.  |
| 11         | PG       | Power Good output signal. PG = "High" means that the power is "Good" for operation and PG = "Low" means "Power fail".  |
| 12         | Vref     | Precision voltage reference is trimmed to ±2% (Typical Value = 5V).  |
| 13         | IS33     | Current sense input for +3.3V output. This pin is connected to the current sensing resistor or inductor. You can define OCP offset voltage for +3.3V by using RI resistor externally. If you connect 62kΩ at pin 8 to ground, the reference current(Iref1) should be 20uA. After that , you can make a constant OCP offset voltage(Voffset=Roffset*5*20uA). In case the voltage drop(IO.33*Rs) of the sense resistor or inductor is larger than offset voltage, after OCP delay time the main SMPS is turned off. So the over current level is determined by the following equation. IO.33=Voffset/Rs. |
| 14         | V33      | OVP, UVP input for +3.3V output (Typical Value = 4.1V/2.3V).   |
| 15         | IS5      | Current sense input for +5V output. You can make +5V OCP function as the previous method in IS5(pin15).  |
| 16         | V5       | OVP, UVP input for +5V output (Typical Value = 6.4V/4.0V).   |
| 17         | IS12     | Current sense input for +12V output. You can make +12V OCP function as the previous method in IS12(pin17).   |
| 18         | V12      | OVP, UVP input for 12V output (Typical Value = 14.2V/10V).   |
| 19         | PT       | This is prepared for an extra OVP input or another protection signal (Typical Value = 1.25V).  |
| 20         | TUVP     | Timing delay pin for under voltage protection and over current protection. Its threshold voltage is 1.8V and clamped to 2.9V after full charging. Target of delay time is 38ms and it is realized through external capacitor (CTUVP = 0.47uF).   |
| 21         | DTC      | Deadtime control input. The deadtime control comparator has an effective 120mV input offset which limits the minimum output dead time. Dead time may be imposed on the output by setting the dead time control input to a fixed voltage, ranging from 0V to 3.3V.  |
| 22         | C2       | Output drive pin for push-pull operation.  |
| 23         | GND      | Ground.  |
| 24         | C1       | Output drive pin for push-pull operation.  |

## Absolute Maximum Ratings

| Characteristics             | Symbol                            | Value      | Unit |
|-----------------------------|-----------------------------------|------------|------|
| Supply Voltage              | V <sub>CC</sub>                   | 40         | V    |
| Collector Output Voltage    | V <sub>C1</sub> , V <sub>C2</sub> | 40         | V    |
| Collector Output Current    | I <sub>C1</sub> , I <sub>C2</sub> | 200        | mA   |
| Power Dissipation (FAN7585) | P <sub>D</sub>                    | 1.5        | W    |
| Operating Temperature Range | T <sub>OPR</sub>                  | -25 to 85  | °C   |
| Storage Temperature Range   | T <sub>STG</sub>                  | -65 to 150 | °C   |

## Temperature Characteristics

| Characteristics   | Symbol                | Min. | Typ. | Max. | Unit |
|---|-----------------------|------|------|------|------|
| Temperature Coefficient of V <sub>ref</sub> (-25°C ≤ T <sub>a</sub> ≤ 85°C) | ΔV <sub>ref</sub> /ΔT | -    | 0.01 | -    | %/°C |

## Electrical Characteristics

( $V_{CC}=20V$ ,  $T_a=25^{\circ}C$ , unless otherwise specified)

| Parameter  | Symbol                    | Condition  | Min. | Typ. | Max. | Unit           |
|--|---------------------------|--|------|------|------|----------------|
| <b>REFERENCE SECTION</b>                         |                           |  |      |      |      |                |
| Reference Output Voltage                         | Vref                      | Iref=1mA   | 4.9  | 5    | 5.1  | V              |
| Line Regulation                                  | $\Delta V_{ref.LINE}$     | $15V \leq V_{CC} \leq 30V$                               | -    | 2.0  | 25   | mV             |
| Load Regulation                                  | $\Delta V_{ref.LOAD}$     | $1mA \leq I_{ref} \leq 10mA$                             | -    | 1.0  | 15   | mV             |
| Temperature Coefficient of Vref <sup>(1)</sup>   | $\Delta V_{ref}/\Delta T$ | $-25^{\circ}C \leq T_a \leq 85^{\circ}C$                 | -    | 0.01 | -    | %/ $^{\circ}C$ |
| Short Circuit Output Current                     | ISC                       | Vref = 0   | 15   | 35   | 75   | mA             |
| <b>OSCILLATOR SECTION</b>                        |                           |  |      |      |      |                |
| Oscillation Frequency                            | fosc                      | $C_T=0.01\mu F$ , $R_T=12k$                              | -    | 9.4  | -    | kHz            |
| Frequency Change with Temperature <sup>(1)</sup> | fosc/T                    | $C_T=0.01\mu F$ , $R_T=12k$                              | -    | 2    | -    | %              |
| <b>DEAD TIME CONTROL SECTION</b>                 |                           |  |      |      |      |                |
| Input Bias Current                               | I <sub>B(DT)</sub>        | -  | -    | -2.0 | -10  | $\mu A$        |
| Maximum Duty Voltage                             | DC <sub>MAX</sub>         | Pin21 (DTC)=0V   | 45   | 48   | 50   | %              |
| Input Threshold Voltage                          | V <sub>TH(DT)</sub>       | Zero Duty Cycle  | -    | 3.0  | 3.3  | V              |
|  |                           | Max. Duty Cycle  | 0    | -    | -    |                |
| <b>ERROR AMP SECTION</b>                         |                           |  |      |      |      |                |
| Inverting Reference Voltage                      | Vref(EA)                  | -  | 1.20 | 1.25 | 1.30 | V              |
| Input Bias Current                               | I <sub>B(EA)</sub>        | V <sub>COMP</sub> =2.5V                                  | -    | -0.1 | -1.0 | $\mu A$        |
| Open-Loop Voltage Gain <sup>(1)</sup>            | G <sub>VO</sub>           | $0.5V \leq V_{COMP} \leq 3.5V$                           | 70   | 95   | -    | dB             |
| Unit-Gain Bandwidth <sup>(1)</sup>               | BW                        | -  | -    | 650  | -    | kHz            |
| Output Sink Current                              | I <sub>SINK</sub>         | V <sub>COMP</sub> = 0.7V                                 | 0.3  | 0.9  | -    | mA             |
| Output Source Current                            | I <sub>SOURCE</sub>       | V <sub>COMP</sub> = 3.5V                                 | -2.0 | -4.0 | -    | mA             |
| <b>PWM COMPARATOR SECTION</b>                    |                           |  |      |      |      |                |
| Input Threshold Voltage                          | V <sub>TH(PWM)</sub>      | Zero Duty Cycle  | -    | 4    | 4.5  | V              |
| <b>OUTPUT SECTION</b>                            |                           |  |      |      |      |                |
| Output Saturation Voltage                        | V <sub>CE(SAT)</sub>      | I <sub>C</sub> = 200mA                                   | -    | 1.1  | 1.3  | V              |
| Collector Off-State Current                      | I <sub>C(off)</sub>       | V <sub>CC</sub> =V <sub>C</sub> =30V, V <sub>E</sub> =0V | -    | 2    | 100  | $\mu A$        |
| Rising Time <sup>(1)</sup>                       | T <sub>R</sub>            | -  | -    | 100  | 200  | ns             |
| Falling Time <sup>(1)</sup>                      | T <sub>F</sub>            | -  | -    | 50   | 200  | ns             |

**Electrical Characteristics** (Continued)(V<sub>CC</sub>=20V, T<sub>a</sub>=25°C, unless otherwise specified)

| Parameter                                   | Symbol                 | Condition                       | Min. | Typ. | Max. | Unit |
|---|------------------------|---------------------------------|------|------|------|------|
| <b>PROTECTION SECTION</b>                   |                        |                                 |      |      |      |      |
| Over Voltage Protection for +3.3V           | VOVP1                  | -                               | 3.8  | 4.1  | 4.3  | V    |
| Over Voltage Protection for +5V             | VOVP2                  | -                               | 6.0  | 6.4  | 6.8  | V    |
| Over Voltage Protection for +12V            | VOVP3                  | -                               | 13.5 | 14.2 | 15.0 | V    |
| Input Threshold Voltage for PT              | VPT                    | -                               | 1.20 | 1.25 | 1.30 | V    |
| Under Voltage Protection for +3.3V          | VUVP1                  | -                               | 2.1  | 2.3  | 2.5  | V    |
| Under Voltage Protection for +5V            | VUVP2                  | -                               | 3.7  | 4.0  | 4.3  | V    |
| Under Voltage Protection for +12V           | VUVP3                  | -                               | 9.2  | 10   | 10.8 | V    |
| Voltage for Current Reference               | VRI                    |                                 | 1.21 | 1.25 | 1.29 | V    |
| Current Reference <sup>(1)</sup>            | Iref1                  |                                 | 10   | -    | 65   | µA   |
| Charging Current for UVP, OCP Delay         | ICHG.UVP               | C=0.47µF                        | -16  | -21  | -28  | µA   |
| UVP, OCP Delay Time                         | TD.UVP                 | C=0.47µF, V <sub>TH</sub> =1.8V | 24   | 38   | 57   | ms   |
| Offset Voltage of OCP Comparator            | VOFFSET                |                                 | -5   | -    | 5    | mV   |
| <b>REMOTE ON/OFF SECTION</b>                |                        |                                 |      |      |      |      |
| REM On Input Voltage                        | VREMH                  | I <sub>REM</sub> = -200µA       | 2.0  | -    | -    | V    |
| REM Off Input Voltage                       | VREML                  | -                               | -    | -    | 0.8  | V    |
| REM Off Input Bias Current                  | I <sub>REML</sub>      | V <sub>REM</sub> = 0.4V         | -    | -    | -1.6 | mA   |
| REM On Open Voltage                         | V <sub>REM(OPEN)</sub> | -                               | 2.0  | -    | 5.25 | V    |
| REM On Delay Time                           | T <sub>on</sub>        | C=0.1µF                         | 4    | 8    | 14   | ms   |
| REM Off Delay Time                          | T <sub>off</sub>       | C=0.1µF                         | 16   | 24   | 34   | ms   |
| <b>REMOTE ON/OFF SECTION <sup>(2)</sup></b> |                        |                                 |      |      |      |      |
| Detecting Input Voltage                     | V <sub>IN(DET)</sub>   | -                               | 1.20 | 1.25 | 1.30 | V    |
| Detecting V5 Voltage                        | V5(DET)                | -                               | 4.1  | 4.3  | 4.5  | V    |
| Hysteresis Voltage 1                        | HY1                    | COMP1, 2                        | 10   | 40   | 80   | mV   |
| Hysteresis Voltage 2                        | HY2                    | COMP3                           | 0.6  | 1.2  | -    | V    |
| PG Output Load Resistor                     | R <sub>PG</sub>        | -                               | 0.5  | 1    | 2    | kΩ   |
| Charging Current for PG Delay               | ICHG.PG                | C=2.2µF                         | -10  | -15  | -23  | µA   |
| PG Delay Time                               | TD.PG                  | C=2.2µF, V <sub>TH</sub> =1.8V  | 100  | 260  | 500  | ms   |
| PG Output Saturation Voltage                | V <sub>SAT(PG)</sub>   | I <sub>PG</sub> =10mA           | -    | 0.2  | 0.4  | V    |
| <b>TOTAL DEVICE</b>                         |                        |                                 |      |      |      |      |
| Standby Supply Current                      | I <sub>CC</sub>        | -                               | -    | 10   | 20   | mA   |

**Note:**

1. These parameters, although guaranteed over their recommended operating conditions are not 100% tested in production.
2. REM on delay time (Pin6 REM: "L" → "H"),  
REM off delay time (Pin6 REM: "H" → "L")

## Application Informations

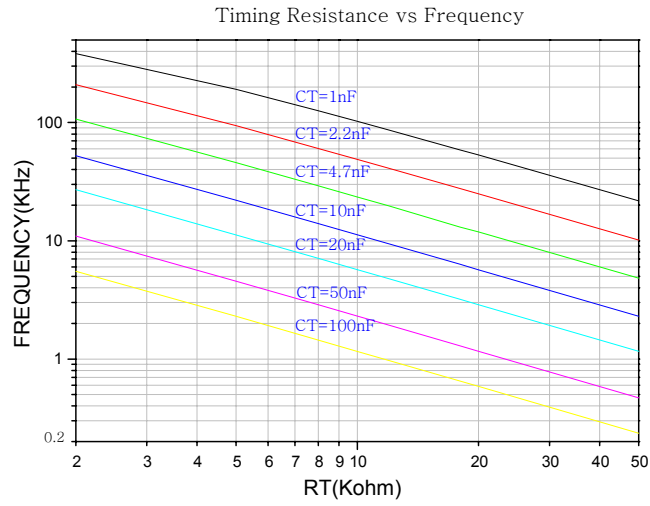

Fig 1. Timing Resistance vs Frequency

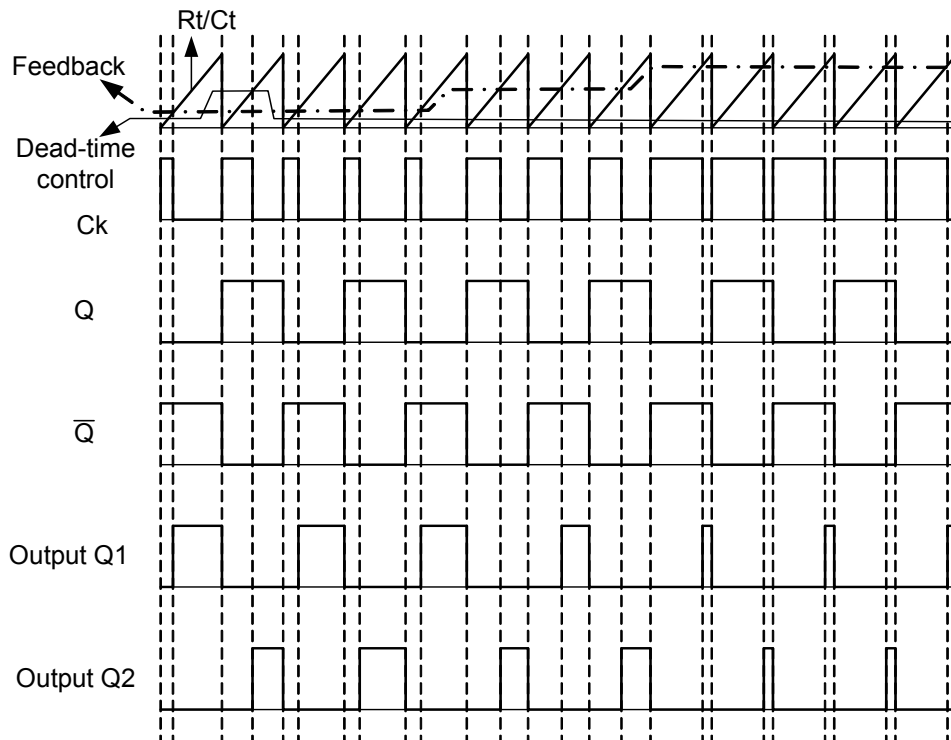
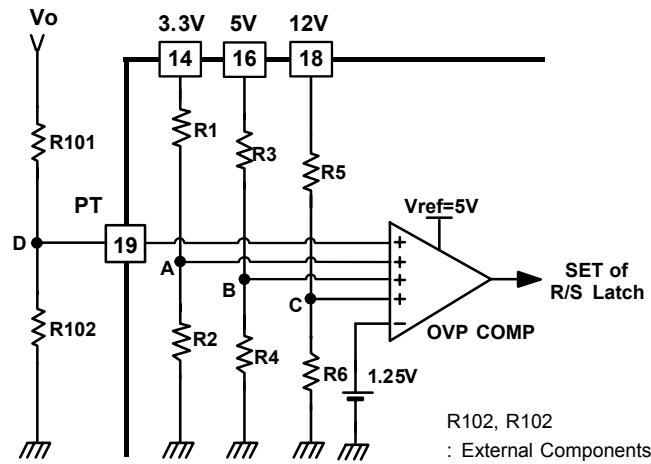

Fig 2. Operating Waveform



## 1. OVP Block



The OVP function is simply realized by connecting Pin14, Pin16, Pin18 to each secondary outputs. R1, R2, R3, R4, R5, R6 are internal resistors of the IC. Each OVP level is determined by resistor ratio and the typical values are 4.1V/6.4V/14.2V respectively.

- **OVP detecting voltage for +3.3V**

$$V_{OVP1}(+3.3V) = \frac{R_1 + R_2}{R_2} \times V_A = \frac{R_1 + R_2}{R_2} \times V_{ref} = 4.1V$$

- **OVP detecting voltage for +5V**

$$V_{OVP2}(+5V) = \frac{R_3 + R_4}{R_4} \times V_B = \frac{R_3 + R_4}{R_4} \times V_{ref} = 6.4V$$

- **OVP detecting voltage for +12V**

$$V_{OVP3}(+12V) = \frac{R_5 + R_6}{R_6} \times V_C = \frac{R_5 + R_6}{R_6} \times V_{ref} = 14.2V$$

Especially, Pin19(PT) is prepared for extra OVP input or another protection signal. That is, if you want over voltage protection of extra output voltage, then you can make a function with two external resistors.

- **OVP detecting voltage for PT**

$$PT = \frac{R_{101} + R_{102}}{R_{102}} \times V_D = \frac{R_{101} + R_{102}}{R_{102}} \times V_{ref}$$

In the case of OVP, a system designer should know a fact that the main power can be dropped after a little time because of system delay, even if PWM is triggered by OVP. So when the OVP level is tested with a set, you should check the secondary outputs(+3.3V/+5V/+12V) and PG(Pin11) simultaneously. Then you can know the each OVP level as checking each output voltage in just time that PG(Pin11) is triggered from high to low.

## 2. UVP Block

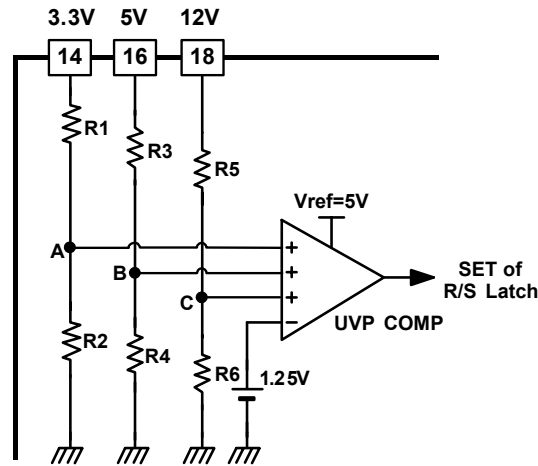

The block is made up of a comparator with three detecting inputs and without hysteresis voltage. Each UVP level is determined by resistor ratio and the typical values are 2.3V/4.0V/10V respectively.

- **UVP detecting voltage for +3.3V**

$$V_{\text{UVP1}(+3.3\text{V})} = \frac{R_1 + R_2}{R_2} \times V_A = \frac{R_1 + R_2}{R_2} \times V_{\text{ref}} = 2.3\text{V}$$

- **UVP detecting voltage for +5V**

$$V_{\text{UVP2}(+5\text{V})} = \frac{R_3 + R_4}{R_4} \times V_B = \frac{R_3 + R_4}{R_4} \times V_{\text{ref}} = 4\text{V}$$

- **UVP detecting voltage for +12V**

$$V_{\text{UVP3}(+12\text{V})} = \frac{R_5 + R_6}{R_6} \times V_C = \frac{R_5 + R_6}{R_6} \times V_{\text{ref}} = 10\text{V}$$

In the case of UVP, a system designer should know a fact that the main power can be dropped after some delay. (38msec@ CTUVP=0.47uF)

So when the UVP level is tested with a set, you should remove protection delay capacitor(Pin20) and check PG(Pin11). You can know the each UVP level as checking each output voltage in just time that PG(Pin11) is triggered from high to low.

### 3. OCP Block

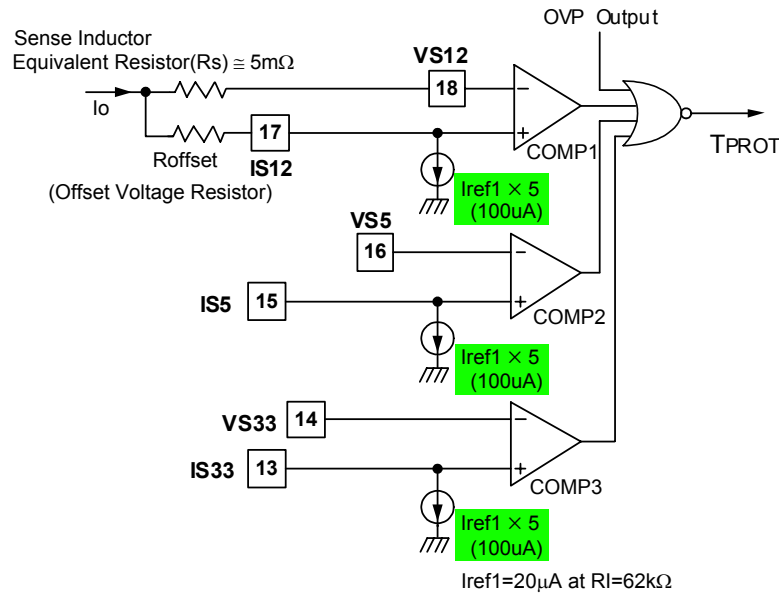

It also has OCP function for +3.3V,+5V,+12V outputs. The block is made up of three comparators. Pin17(IS12), pin15(IS5) and pin13(IS33) are current sense inputs for +12V, +5V and +3.3V outputs respectively. These pins are connected to the current sensing resistor or inductor.

Each OCP level is determined by RI resistor, so you can define over current protection level by changing RI resistor. Pin8(RI) voltage is always 1.25V, so if you connect 62kΩ resistor, the reference current is 20μA(Iref1).

If the voltage drop of the sense resistor or inductor is larger than offset voltage ( $V_{offset} = R_{offset} \times 5 \times I_{ref1}$ ), the DTC becomes "High" after some delay(38ms at  $C_{TUVP}=0.47\mu F$ )and the main SMPS is turned off. That means the output voltage(+3.3V, +5V, +12V) will be ground level.

After main power is turned off at OCP and initialized by REM, if REM signal is changed from "High" to "Low", main power becomes operational.

For example, if you want to define 5V output OCP level at 10A in the condition of equivalent resistor( $R_s$ )= 5mΩ, you can determine the offset voltage resistor( $R_{offset}$ ) as following method.

- $I_{ref1} = 1.25V / 62k\Omega = 20\mu A$
- $V_{offset} = R_s \times 5 \times I_{ref1} = 5m\Omega \times 10A = 50mV$
- Therefore,  $R_{offset} = 50mV / (5 \times I_{ref1}) = 500\Omega$

By the way, OCP output signal can be delayed by protection delay capacitor( $C_{TUVP}$ ) and its delay time is decided by the value of  $C_{TUVP}$ .

$$T_{uvp} \approx \frac{C_{TUVP} \cdot \Delta V}{\Delta I} = \frac{0.47\mu F \cdot 1.7V}{21\mu A} = 38msec$$

If you use too small (or large) capacitor, the charging time would decrease (or increase) very much and it can cause malfunction at the transient time. So you have to choose the reasonable delay time for system optimization by changing the external capacitor value.

4. Remote On/Off & Delay Block

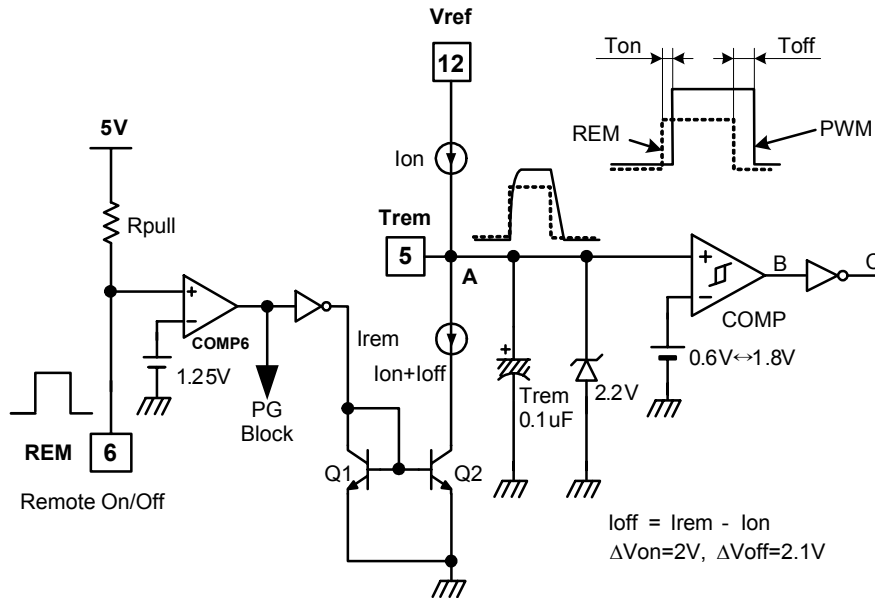

Remote On/Off section is controlled by a microprocessor. If a high signal is supplied to the Remote On/Off input(Pin6), the output of COMP6 becomes high status. The output signal is transferred to ON/OFF delay block and PG block. If no signal is supplied to Pin6, Pin6 maintains high status(=5V) for pull-up resistor, Rpull. When Remote On/Off is high, it produces PWM(Pin6) "High" signal after ON delay time (about 8ms with CTREM=0.1uF) for stabilizing system. Then, all outputs (+3.3V, +5V, +12V) are grounded. When Remote On/Off is changed to "Low", it produces PWM "Low" signal after Off delay time (about 24ms with CTREM=0.1uF) for stabilizing the system. If REM is low, then PWM is low. That means the main SMPS is operational. When REM is high, PWM is high and the main SMPS is turned off. Remote On/Off delay time can be calculated by following equation.

$$T_{on} = K_1 \times \frac{C_{TREM} \times \Delta V_{on}}{I_{on}} \approx 0.95 \times \frac{0.1\mu F \times 2V}{23\mu A} = 8msec$$

$$T_{off} = K_2 \times \frac{C_{TREM} \times \Delta V_{off}}{I_{off}} \approx 0.8 \times \frac{0.1\mu F \times 2.1V}{7\mu A} = 24msec$$

k1, k2: constant value gotten by test

In above equation, a typical capacitor value is 0.1uF. If the capacitor is changed to larger value, it can cause malfunction in case of AC power on at "REM=High". Because PWM maintains Low status and main power turns on for on delay time. So you should use 0.1uF or smaller capacitor.

## 5. Power Good Signal Generator

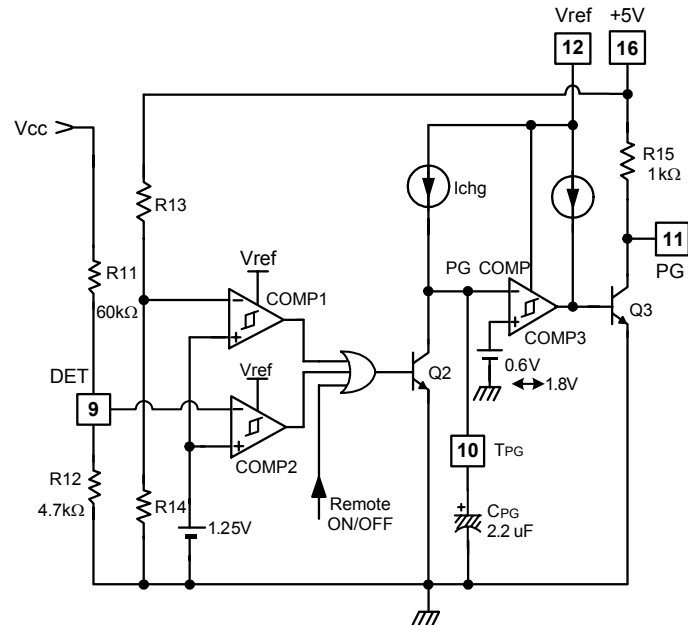

Power Good Signal Generator circuit generates "ON or OFF" signal depending on the status of output voltage to prevent the malfunctions of following systems like microprocessor, etc. caused by the output instability at power on or off. At power on, it produces PG "High" signal after some delay time (about 260ms with  $C_{TPG}=2.2\mu\text{F}$ ) for stabilizing output voltage. At power off, it produces PG "Low" signal without delay time by sensing the status of power source for protecting following systems. Vcc detection point (Pin9) can be calculated by following equation. Recommended values of R11, R12 are determined by the following equation.

$$\text{DET} = 1.25\text{V} \times \left(1 + \frac{R11}{R12}\right) = 17.2\text{V}$$

The COMP3 creates PG "Low" without delay when +5V output falls to less than 4.0V to prevent some malfunction at transient status, thus it improves system stability.

When Remote On/Off signal is high, it generates PG "Low" signal without delay. It means that PG becomes "Low" before main power is grounded.

PG delay time ( $T_{PG}$ ) is determined by capacitor value ( $C_{TPG}$ ), threshold voltage of COMP3 and the charging current and its equation is as following.

$$T_{PG} = \frac{C_{TPG} \times \Delta V}{I_{chg}} \approx \frac{C_{TPG} \times V_{th}}{I_{chg}} = \frac{2.2\mu\text{F} \times 1.8\text{V}}{15\mu\text{A}} \approx 260\text{msec}$$

Considering the lightning surge and noise, there are two types of protections. One is a few time delay between TPG and PG for safe operation and another is some noise margin of Pin10.

$$\text{Noise\_Margin\_of\_TPG} = V_{\text{Pin10(max)}} - V_{th(L)} = 2.9\text{V} - 0.6\text{V} = 2.3\text{V}$$

# Typical Application Circuit

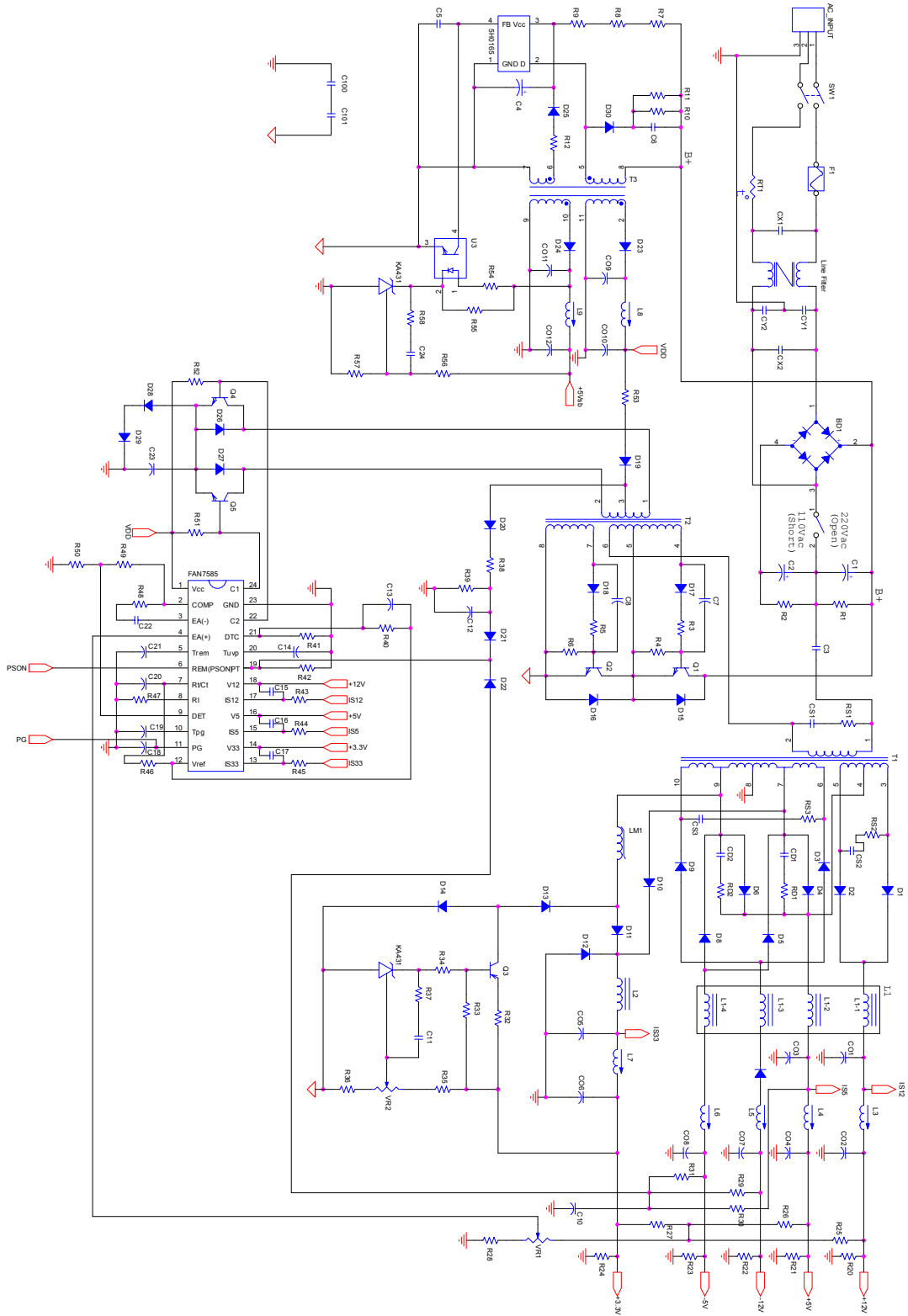

# Mechanical Dimensions

Package

Dimensions in millimeters

## 24-SDIP

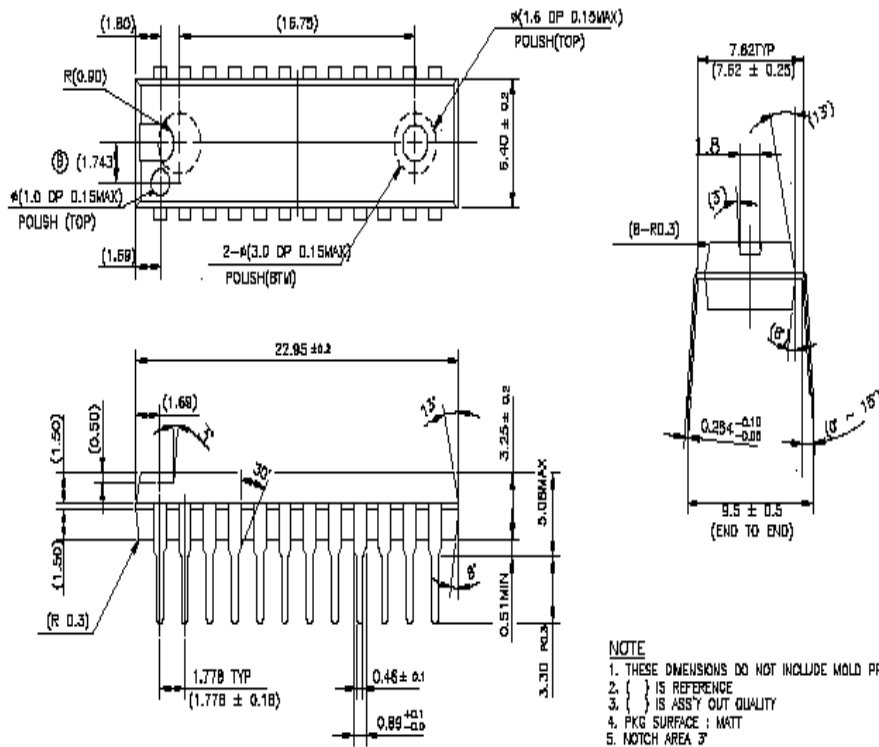

## Ordering Information

| Product Number | Package | Operating Temperature |
|----------------|---------|-----------------------|
| FAN7585        | 24-SDIP | -25°C ~ 85°C          |

### DISCLAIMER

FAIRCHILD SEMICONDUCTOR RESERVES THE RIGHT TO MAKE CHANGES WITHOUT FURTHER NOTICE TO ANY PRODUCTS HEREIN TO IMPROVE RELIABILITY, FUNCTION OR DESIGN. FAIRCHILD DOES NOT ASSUME ANY LIABILITY ARISING OUT OF THE APPLICATION OR USE OF ANY PRODUCT OR CIRCUIT DESCRIBED HEREIN; NEITHER DOES IT CONVEY ANY LICENSE UNDER ITS PATENT RIGHTS, NOR THE RIGHTS OF OTHERS.

### LIFE SUPPORT POLICY

FAIRCHILD'S PRODUCTS ARE NOT AUTHORIZED FOR USE AS CRITICAL COMPONENTS IN LIFE SUPPORT DEVICES OR SYSTEMS WITHOUT THE EXPRESS WRITTEN APPROVAL OF THE PRESIDENT OF FAIRCHILD SEMICONDUCTOR CORPORATION. As used herein:

1. Life support devices or systems are devices or systems which, (a) are intended for surgical implant into the body, or (b) support or sustain life, and (c) whose failure to perform when properly used in accordance with instructions for use provided in the labeling, can be reasonably expected to result in a significant injury of the user.
2. A critical component in any component of a life support device or system whose failure to perform can be reasonably expected to cause the failure of the life support device or system, or to affect its safety or effectiveness.