

SIGN	DATE	DESCRIPTION	APPROVER
△	2010.06.07	Add cULUS standard	Cheng Bo
△	2010.06.07	The flange screw is changed from "-" type to "+/-" type	Cheng Bo
△	2010.06.07	The Voltage rating is changed from 600VAC to 300VAC	Cheng Bo
△	2010.06.07	The material is changed from Brass to Copper	Cheng Bo
△	2011.07.04	The Tolerance is changed	Aaron

THIS IS CAD DRAWING, DO NOT REVISE MANUALLY!!!

**Material**

- Item a Terminal body:Thermoplastic ( UL94V-0 )
- Item b Terminal cover:Thermoplastic ( UL94V-0 )
- Item c Terminal screw:Steel Cr3+ Zinc plating "-" slot type
- Item d Clamp:Brass, Ni plated
- △ ● Item e Male contant pin:Copper Gold plated
- △ ● Item f With flange screw:Steel Zinc plating M3"+/-"slot type

**Electrical cULUS / IEC**

- △ ● Voltage rating: 300VAC / 1000VAC
- Current rating: 55A / 76A
- Solid wire: 6-20 / 0.5-16mm<sup>2</sup>
- Stranded wire: 6-20 / 0.5-16mm<sup>2</sup>
- Torque: 18 Lb-In / 2.0 N.m
- Screw: M4.5
- Wire strip length: 13-14mm
- △ ● Withstanding Voltage: 16KV / 8KV
- Operating temperature: -40°C to +115°C
- △ ● Safety Approval: us
- Critical dimension: ▽

**PART NO. KK xx 61 x 1 xxxx G**

No. OF POLES ————

02 2 CONTACTS

03 3 CONTACTS

... ..

12 12 CONTACTS

Color

0 Black (RAL9005)

2 Red (RAL3001/D)

3 Orange(RAL2011/P)

4 Yellow(RAL1018/A)

5 Green(RAL6018/T)

6 Blue (RAL5015/A)

8 Grey(RAL7035/D)

9 White(RAL1102)

C Green(RAL6018/U)

G: Pb<40000ppm

0000: "@ " Logo (Standard)

000A: "ANYTEK" Mark

Any special item by customer request. please contact sales department.

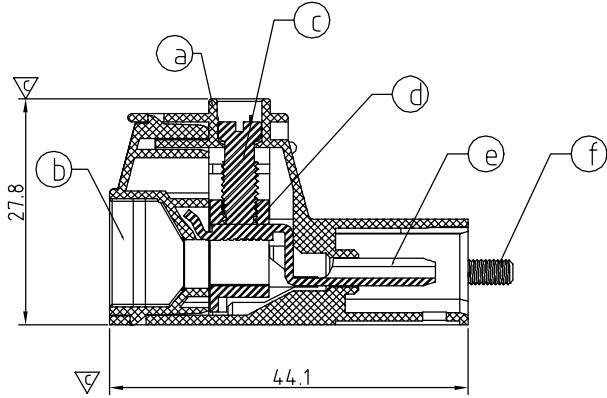
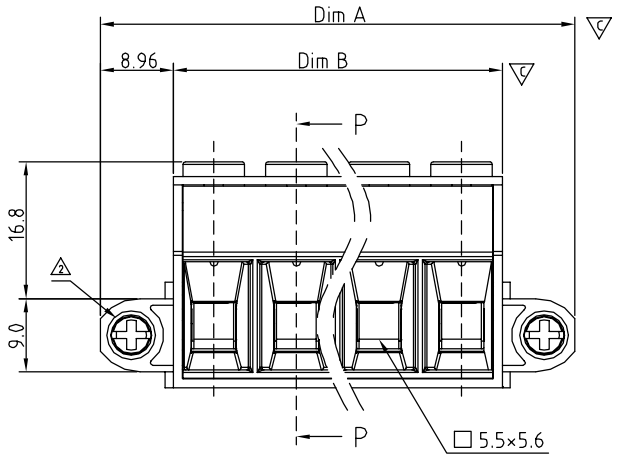
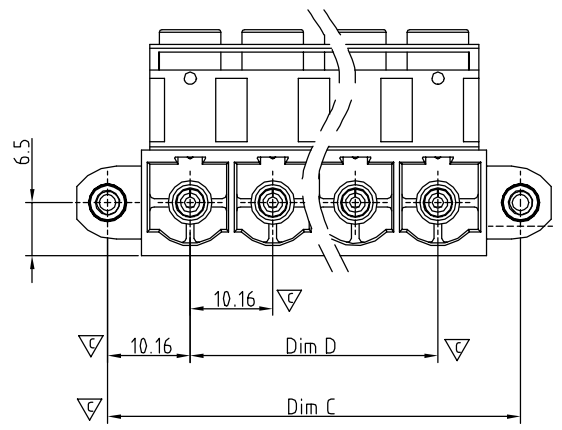
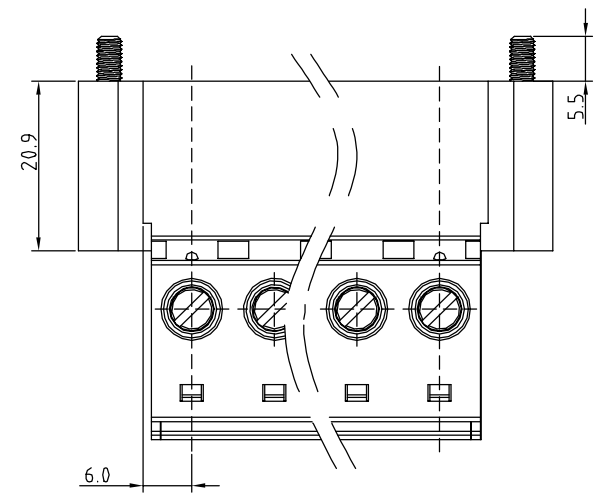

SECTION P-P

N= Number of poles

Dim A	Dim B	Dim C	Dim D	Poles	Tolerance
N×10.16+17.76	N×10.16-0.16	(N-1)×10.16+20.32	(N-1)×10.16	2P-4P	±0.25
				5P-7P	±0.30
				8P-10P	±0.35
				11P-12P	±0.45

<b>ANYTEK</b>				<b>CUSTOMER COPY</b>			
ALL RIGHTS RESERVED. REPRODUCTION OR ISSUE TO THIRD PARTIES IN ANY FORM WHATSOEVER IS NOT PERMITTED WITHOUT WRITTEN AUTHORITY FROM THE PROPRIETOR. PROPERTY OF ANYTEK TECHNOLOGY CO., LTD							
TITLE		KK 10.16 Series 2p-12p (W/F)					
PART NO.		KKxx61x1xxxxG			DWG NO.		8KK0002
APPROVED		CHECKED		DESIGNED		DRAWN	
				Aaron 2011.07.04		Cheng Bo 2010.06.07	
						CUST NO.	
						Tolerance	
						X. ±0.50	
						X.X ±0.30	
						X.XX ±0.10	
						X° ±1°	
						UNIT: mm	
						SCALE: NONE	
						SHEET: 01/01	
						REV.: D	