

Main Product Characteristics

BV_{DSS}	650V
$R_{DS(ON)}$	190m Ω
I_D	20A

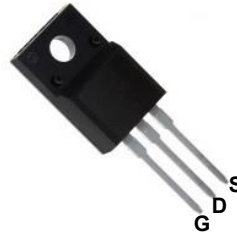

TO-220F

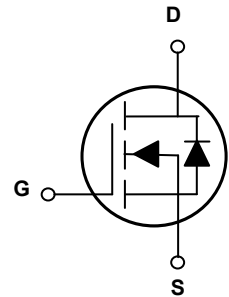

Schematic Diagram



Features and Benefits

- Advanced MOSFET process technology
- Ideal for high efficiency switched mode power supplies
- Low on-resistance with low gate charge
- Fast switching and reverse body recovery

Description

The GSFU6522 utilizes the latest techniques to achieve high cell density and low on-resistance. These features make this device extremely efficient and reliable for use in high efficiency switch mode power supply and a wide variety of other applications.

Absolute Maximum Ratings ($T_C=25^\circ\text{C}$ unless otherwise specified)

Parameter	Symbol	Max.	Unit
Drain-Source Voltage	V_{DS}	650	V
Gate-Source Voltage	V_{GS}	± 30	V
Drain Current-Continuous ($T_C=25^\circ\text{C}$)	I_D	20	A
Drain Current-Continuous ($T_C=100^\circ\text{C}$)		12.5	
Drain Current-Pulsed ¹	I_{DM}	80	A
Single Pulse Avalanche Energy	E_{AS}	420	mJ
Power Dissipation ($T_C=25^\circ\text{C}$)	P_D	45	W
Power Dissipation-Derate above 25°C		0.36	
Thermal Resistance, Junction-to-Ambient	$R_{\theta JA}$	62	$^\circ\text{C/W}$
Thermal Resistance, Junction-to-Case	$R_{\theta JC}$	2.75	$^\circ\text{C/W}$
Operating Junction Temperature Range	T_J	-55 To +150	$^\circ\text{C}$
Storage Temperature Range	T_{STG}	-55 To +150	$^\circ\text{C}$

Electrical Characteristics ($T_J=25^{\circ}\text{C}$ unless otherwise specified)

Parameter	Symbol	Conditions	Min.	Typ.	Max.	Unit
On/Off Characteristics						
Drain-Source Breakdown Voltage	BV_{DSS}	$V_{GS}=0V, I_D=1mA$	650	-	-	V
Drain-Source Leakage Current	I_{DSS}	$V_{DS}=650V, V_{GS}=0V, T_J=25^{\circ}\text{C}$	-	-	1	μA
		$V_{DS}=520V, V_{GS}=0V, T_J=125^{\circ}\text{C}$	-	-	10	μA
Gate-Source Leakage Current	I_{GSS}	$V_{GS}=\pm 30V, V_{DS}=0V$	-	-	± 100	nA
Static Drain-Source On-Resistance	$R_{DS(ON)}$	$V_{GS}=10V, I_D=10A$	-	160	190	m Ω
Gate Threshold Voltage	$V_{GS(th)}$	$V_{GS}=V_{DS}, I_D=250\mu\text{A}$	2	3	4	V
Dynamic and Switching Characteristics						
Total Gate Charge ^{2,3}	Q_g	$V_{DS}=480V, I_D=10A, V_{GS}=10V$	-	47	70	nC
Gate-Source Charge ^{2,3}	Q_{gs}		-	5	8	
Gate-Drain Charge ^{2,3}	Q_{gd}		-	14	21	
Turn-On Delay Time ^{2,3}	$t_{d(on)}$	$V_{DD}=480V, R_G=25\Omega, V_{GS}=10V, I_D=10A$	-	32	48	nS
Rise Time ^{2,3}	t_r		-	73	110	
Turn-Off Delay Time ^{2,3}	$t_{d(off)}$		-	146	220	
Fall Time ^{2,3}	t_f		-	47	70	
Input Capacitance	C_{iss}	$V_{DS}=100V, V_{GS}=0V, F=1\text{MHz}$	-	1400	2100	pF
Output Capacitance	C_{oss}		-	55	85	
Reverse Transfer Capacitance	C_{rss}		-	1.3	4.6	
Gate Resistance ^{2,3}	R_g	$V_{GS}=0V, V_{DS}=0V, F=1\text{MHz}$	-	8	-	Ω
Drain-Source Diode Characteristics and Maximum Ratings						
Continuous Source Current	I_S	$V_G=V_D=0V, \text{Force Current}$	-	-	20	A
Pulsed Source Current	I_{SM}		-	-	40	A
Diode Forward Voltage	V_{SD}	$V_{GS}=0V, I_S=10A, T_J=25^{\circ}\text{C}$	-	-	1.4	V
Reverse Recovery Time	t_{rr}	$V_R=400V, I_S=10A, di/dt=100A/\mu\text{s}, T_J=25^{\circ}\text{C}$	-	310	-	nS
Reverse Recovery Charge	Q_{rr}		-	4.4	-	μC

Note:

1. Repetitive rating: Pulsed width limited by maximum junction temperature.
2. Pulse test: pulse width $\leq 300\mu\text{s}$, duty cycle $\leq 2\%$.
3. Essentially independent of operating temperature.

Typical Electrical and Thermal Characteristic Curves

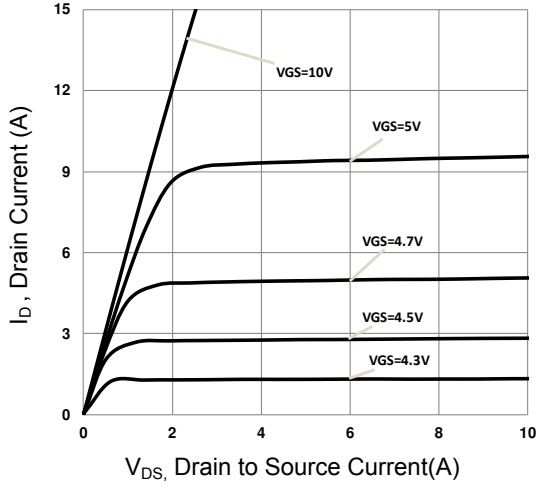

Figure 1. Typical Output Characteristics

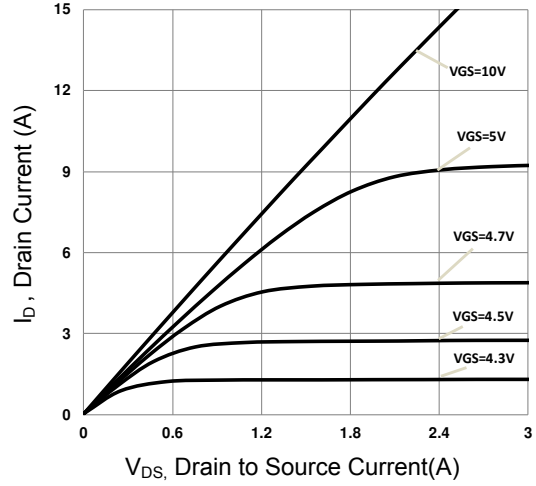

Figure 2. Typical Output Characteristics

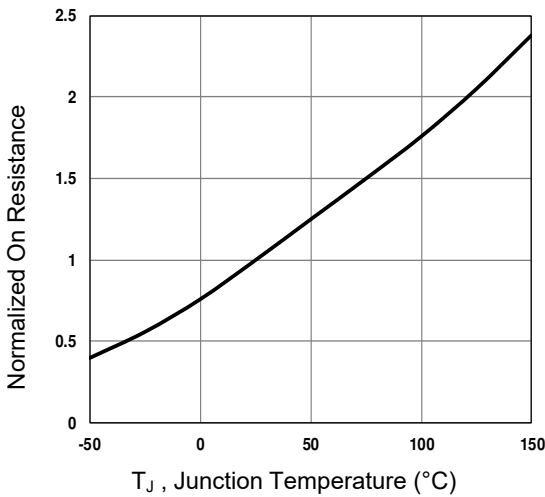

Figure 3. Normalized $R_{DS(ON)}$ vs. T_J

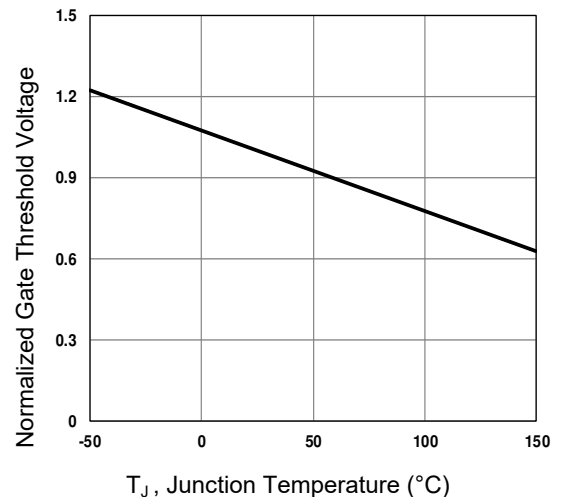

Figure 4. Normalized V_{th} vs. T_J

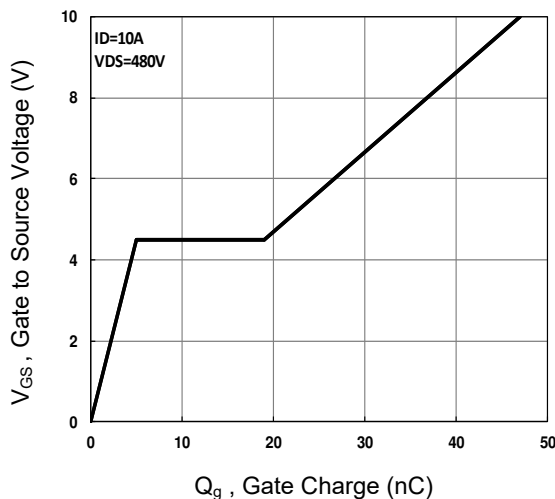

Figure 5. Gate Charge Waveform

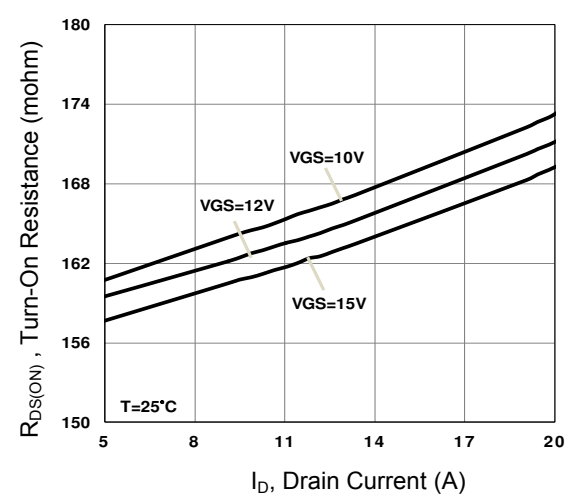

Figure 6. Turn-On Resistance vs. I_D

Typical Electrical and Thermal Characteristic Curves

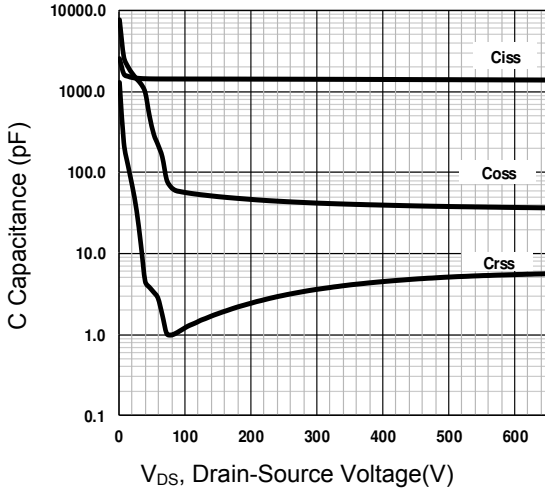

Figure 7. Capacitance vs. V_{DS}

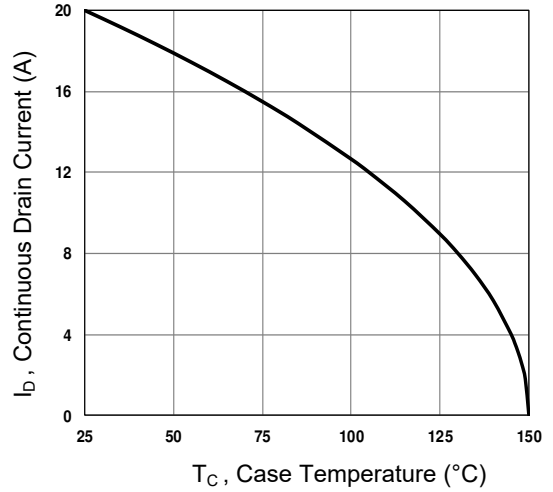

Figure 8. Continuous Drain Current vs. T_C

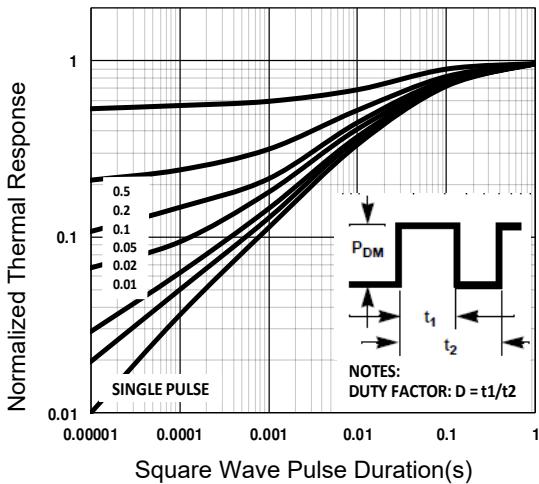

Figure 9. Normalized Transient Impedance

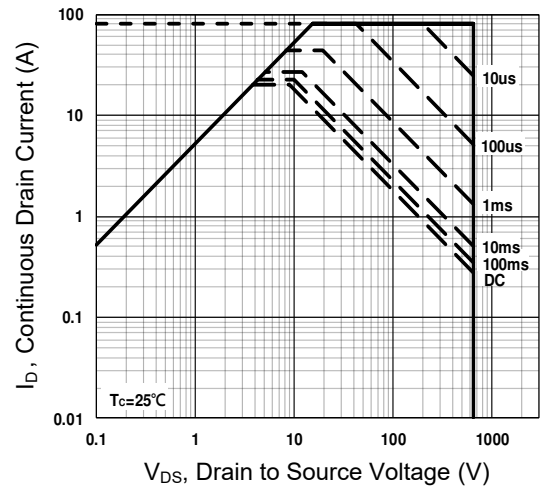

Figure 10. Maximum Safe Operation Area

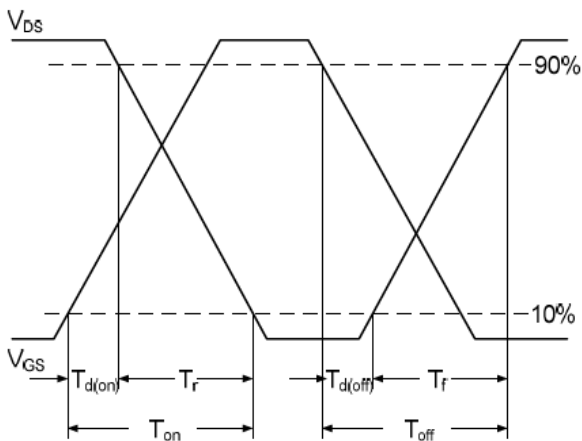

Figure 11. Switching Time Waveform

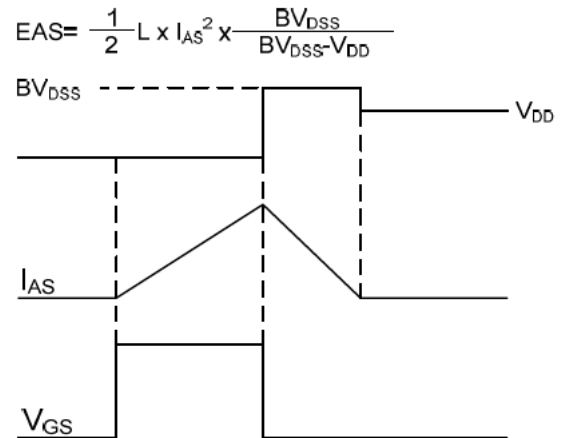
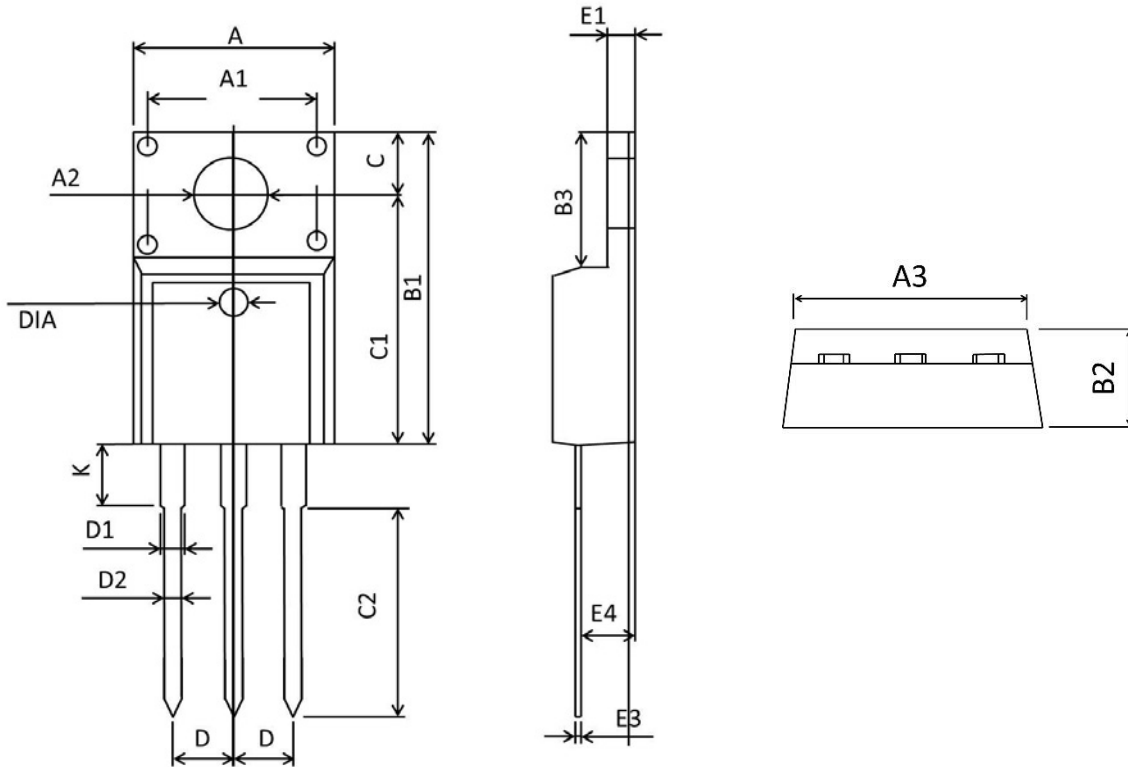

Figure 12. EAS Waveform

Package Outline Dimensions (TO-220F)



Symbol	Dimensions In Millimeters		Dimensions In Inches	
	Min	Max	Min	Max
A	9.860	10.460	0.389	0.411
A1	6.900	7.100	0.272	0.280
A2	3.100	3.500	0.122	0.138
B1	15.450	16.300	0.608	0.642
B2	4.400	5.000	0.173	0.197
B3	6.280	7.100	0.247	0.280
C	3.100	3.500	0.122	0.138
C1	12.270	12.870	0.483	0.507
C2	9.600	10.520	0.378	0.414
D	2.540BSC		0.1BSC	
D1	1.070	1.470	0.042	0.058
D2	0.600	1.000	0.024	0.039
K	2.800	3.500	0.110	0.138
E1	2.340	2.740	0.092	0.108
E3	0.350	0.650	0.014	0.026
E4	2.460	2.960	0.097	0.117
DIA	1.35	1.65	0.053	0.065