

| REVISIONS |     |                       |           |          |
|-----------|-----|-----------------------|-----------|----------|
| P         | LTN | DESCRIPTION           | DATE      | OWN APVD |
| C12       |     | REV PER ECN-23-201432 | 03MAR2023 | CN GK    |
| C13       |     | REV PER ECN-23-213135 | 22MAY2023 | CN GK    |
| C14       |     | REV PER ECN-23-222323 | 18JUL2023 | CN GK    |
| C15       |     | REV PER ECN-23-225107 | 04AUG2023 | CN GK    |

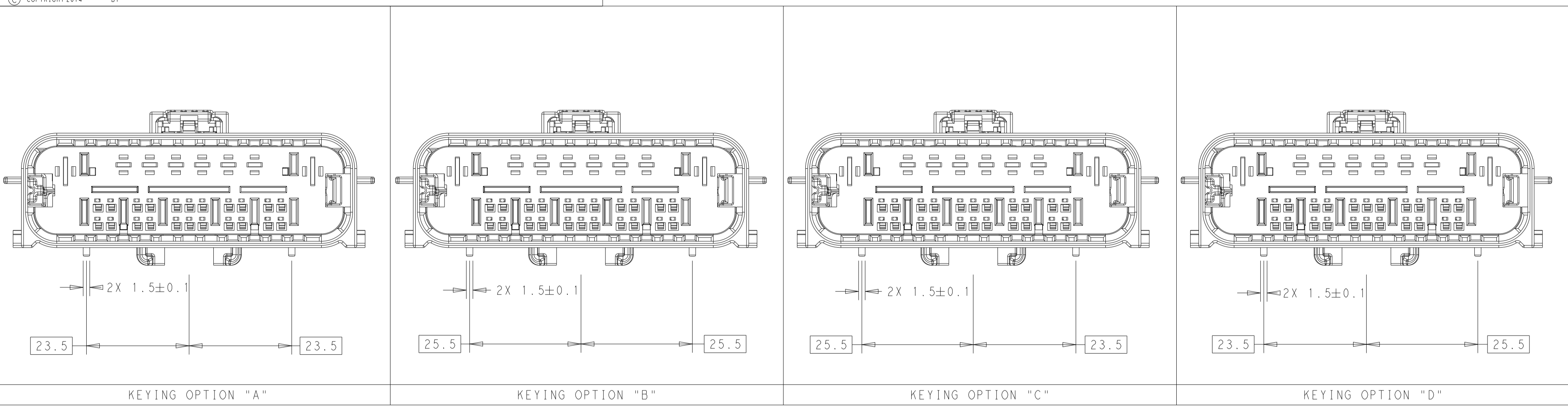

- NOTES:
- MATERIAL:  
 INNER HOUSING-PBT, 30% GLASS FILLED, BLACK  
 OUTER HOUSING-NYLON 6/6, 35% GLASS FILLED, SEE TABLE FOR COLOR  
 MAT SEAL-SILICONE RUBBER, INHERENTLY LUBRICATED, LT BLUE  
 SEAL COVER-PBT, 15% GLASS FILLED, BLACK  
 ISL-PBT, 30% GLASS FILLED, LT GRAY  
 PIN PLATE-PBT, 15% GLASS FILLED, WHITE  
 CPA-PBT, 15% GLASS FILLED, RED
  - 2301461-1 SHOWN IN GENERAL VIEWS.
  - ISL SHOWN IN PRE-SET, SHIPPING POSITION. DIMENSION SHOWN FROM ISL TO INNER HOUSING
  - CPA SHOWN IN PRE-SET, SHIPPING POSITION.
  - PIN PLATE SHOWN IN PRE-SET, SHIPPING POSITION.
  - JULIAN DATE CODE (YYDD HH:MM:SS) AND ASSEMBLY PART NUMBER (XXXXXX-X) MARKED IN APPROXIMATE LOCATION.
  - IF SEATED IN SHIPPING. SEE INSTRUCTION SHEET 408-32159 FOR INSTRUCTIONS TO RETURN TO SHIPPING POSITION.
  - MATES WITH TE PLUG ASSEMBLY: 2301462-X
  - CLIP SLOT PER EWCAP-005-23, 23mm CLIP SLOT
  - VOID CORE, CONSTRUCTION OPTIONAL

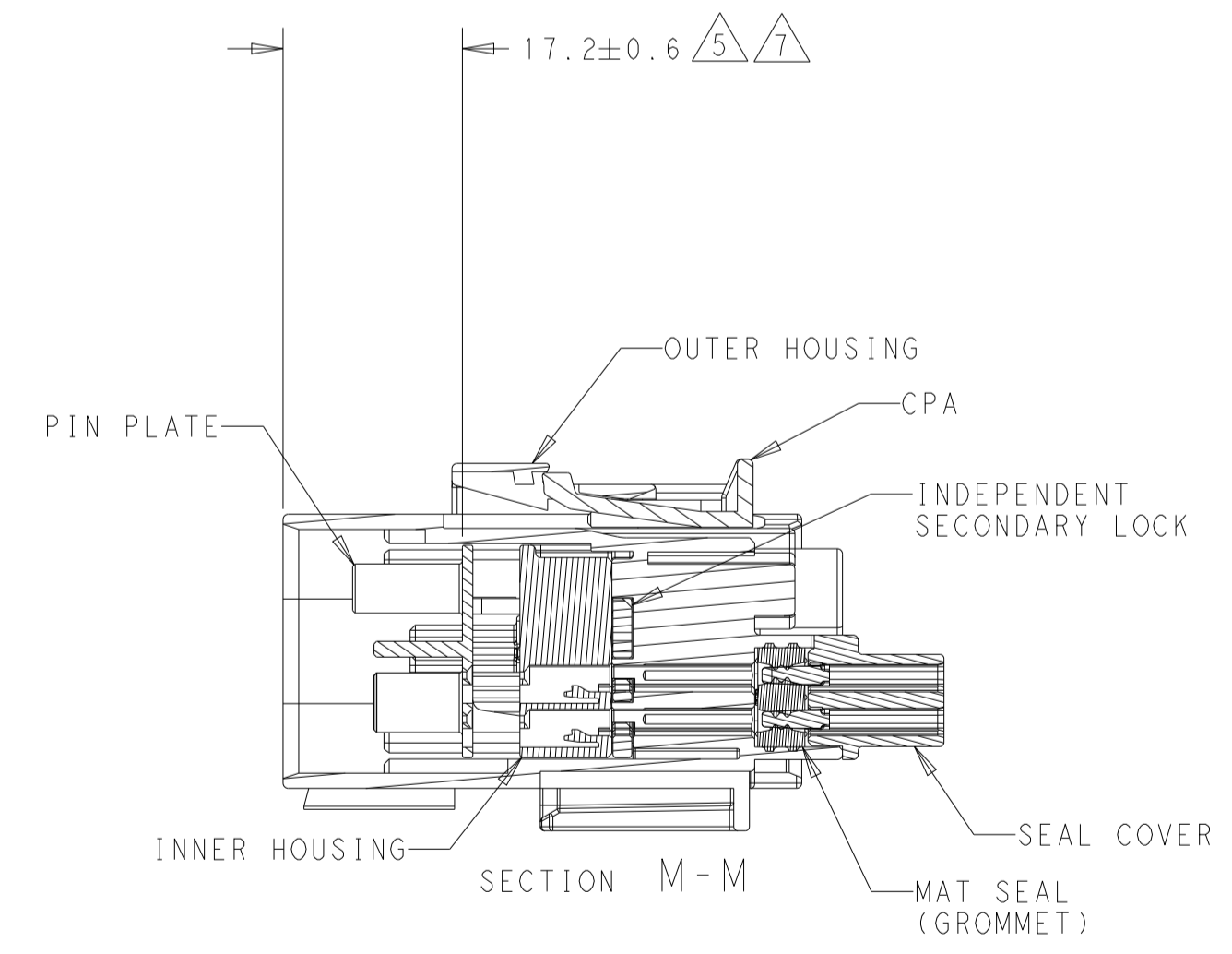
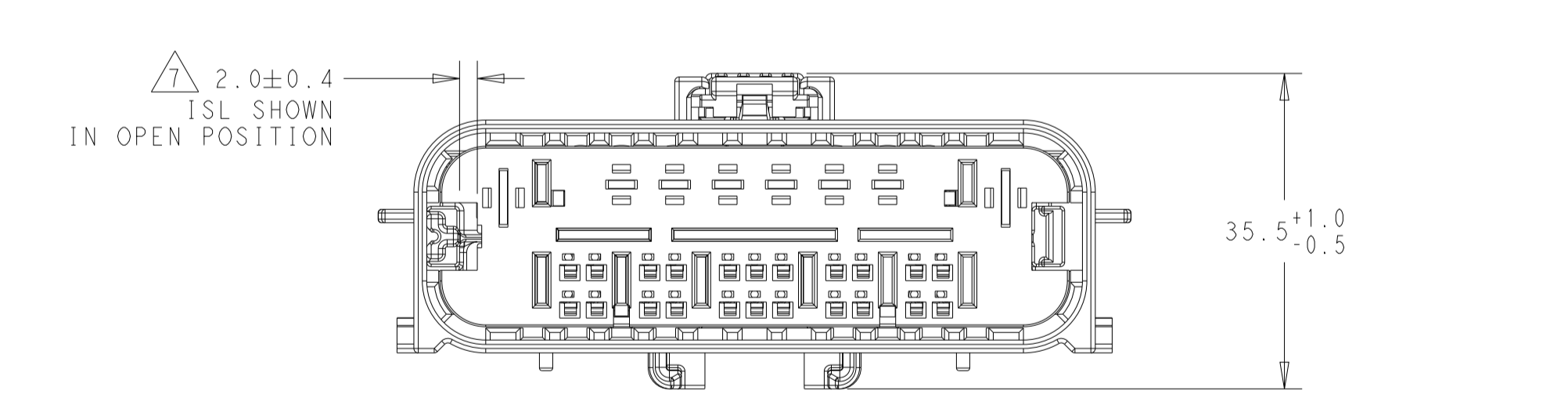
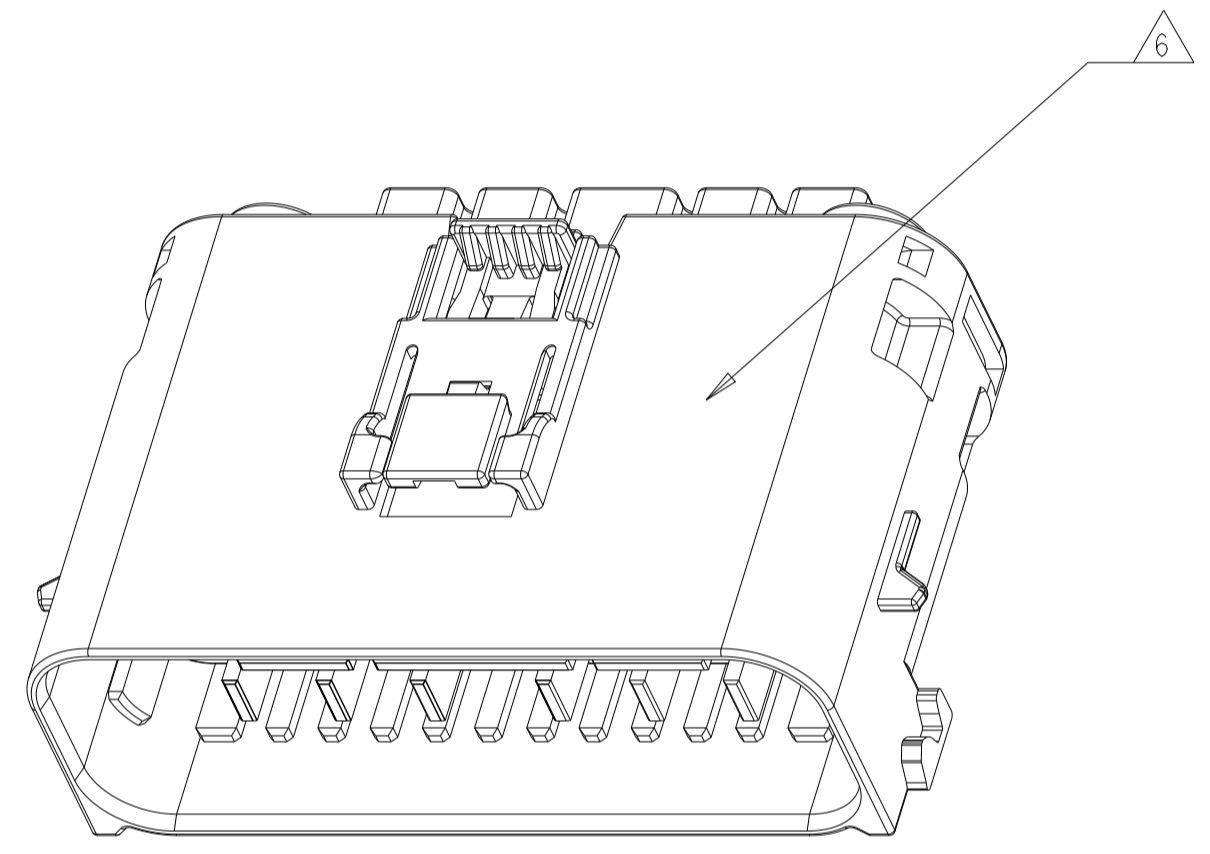
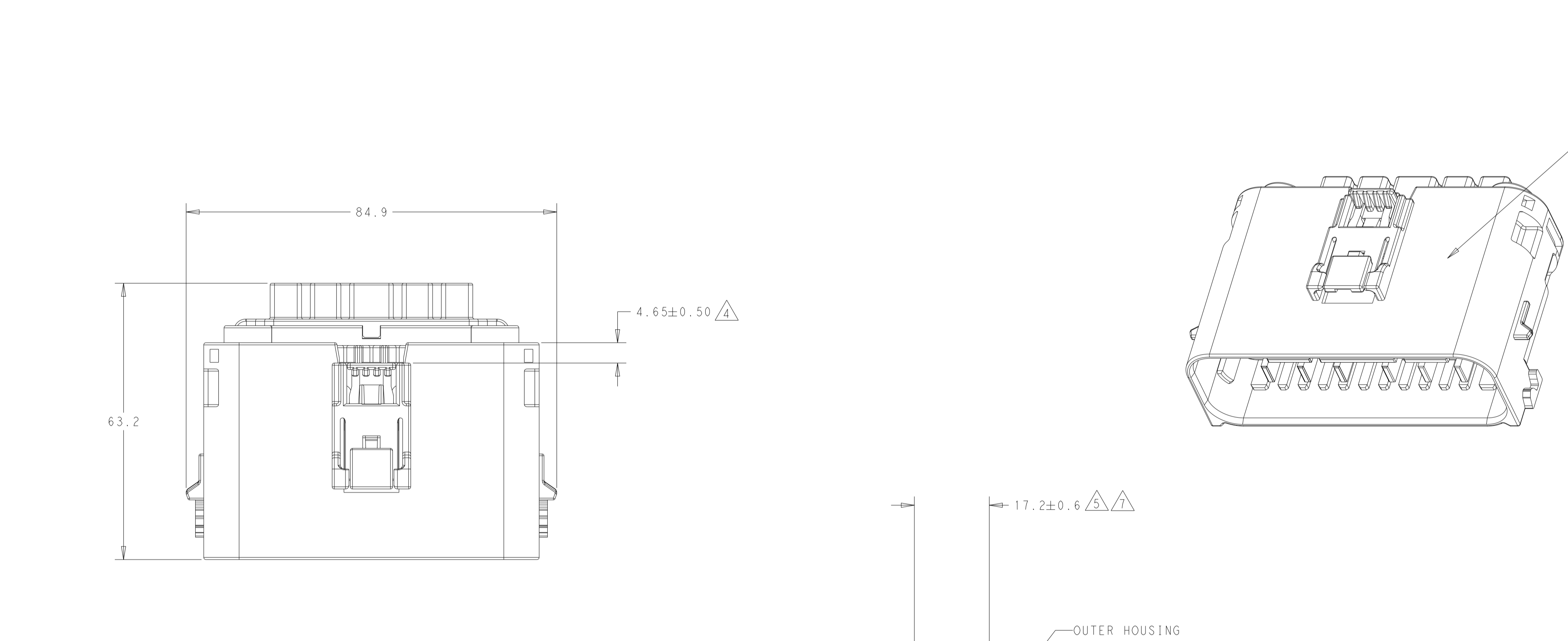

| APPLICABLE COMPONENTS |          |                     |                     |            |
|-----------------------|----------|---------------------|---------------------|------------|
| TERMINALS             |          |                     |                     |            |
| CIRCUITS              | TERMINAL | MIN WIRE SIZE       | MAX WIRE SIZE       | PART #     |
| 1 AND 8               | MCP 6.3  | 0.5mm <sup>2</sup>  | 1.0mm <sup>2</sup>  | 1-962917-1 |
|                       |          | >1.0mm <sup>2</sup> | 2.5mm <sup>2</sup>  | 1-962918-1 |
|                       |          | 4.0mm <sup>2</sup>  |                     | 1-962919-1 |
| 2 - 7                 | MCP 2.8  | 0.5mm <sup>2</sup>  | 1.0mm <sup>2</sup>  | 1-962915-1 |
|                       |          | >1.0mm <sup>2</sup> | 2.5mm <sup>2</sup>  | 1-962916-1 |
| 9 - 30                | MCON 1.2 | 0.35mm <sup>2</sup> |                     | 1718348-1  |
|                       |          | 0.5mm <sup>2</sup>  | 0.75mm <sup>2</sup> | 1718350-1  |
| WIRE SEALS            |          |                     |                     |            |
| CIRCUITS              | TERMINAL | MIN WIRE O.D.       | MAX WIRE O.D.       | PART #     |
| 1 AND 8               | MCP 6.3  | 1.4                 | 2.0                 | 2177018-1  |
|                       |          | 2.0                 | 2.7                 | 1394511-1  |
|                       |          | 2.7                 | 3.0                 | 1823111-1  |
|                       |          | 3.4                 | 3.7                 | 1394512-1  |
| 2 - 7                 | MCP 2.8  | 4.0                 | 4.5                 | 1719043-1  |
|                       |          | 1.4                 | 2.0                 | 828904-1   |
|                       |          | 2.2                 | 3.0                 | 828905-1   |
| CAVITY PLUGS          |          |                     |                     |            |
| CIRCUITS              | TERMINAL | PART #              |                     |            |
| 1 AND 8               | MCP 6.3  | 967652-1            |                     |            |
| 2 - 7                 | MCP 2.8  | 828922-1            |                     |            |
| 9 - 30                | MCON 1.2 | 2304518-1           |                     |            |

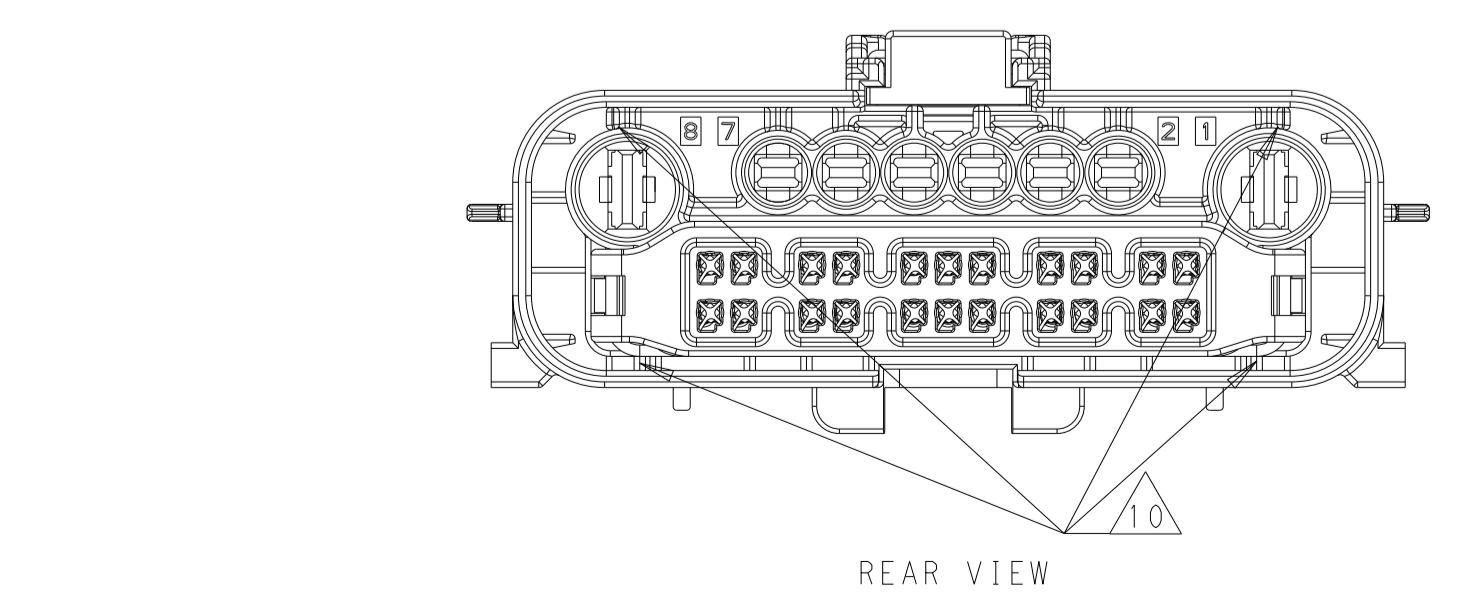

THIS DRAWING IS A CONTROLLED DOCUMENT. OWN: R. HETRICK 18APR2016  
 CHK: R. HETRICK 18APR2016  
 APVD: R. HETRICK 18APR2016

**STE** TE Connectivity

NAME: 30P SEALED HYBRID CAP ASSEMBLY

SIZE: A1 CAGE CODE: - DRAWING NO: C=2301461

RESTRICTED TO: -

CUSTOMER DRAWING SCALE: 3:2 SHEET 1 OF 5 REV: C15

| DIMENSIONS: | TOLERANCES UNLESS OTHERWISE SPECIFIED: |
|-------------|--|
| mm          | 0 PLC ±0.5                             |
|             | 1 PLC ±0.3                             |
|             | 3 PLC ±0.3                             |
|             | 4 PLC ±0.3                             |
|             | ANGLES ±0.5°                           |
|             | FINISH                                 |

| REVISIONS |     |             |      |      |
|-----------|-----|-------------|------|------|
| P         | LTN | DESCRIPTION | DATE | APVD |
| -         | -   | SEE SHEET 1 | -    | -    |
| -         | -   | -           | -    | -    |
| -         | -   | -           | -    | -    |
| -         | -   | -           | -    | -    |

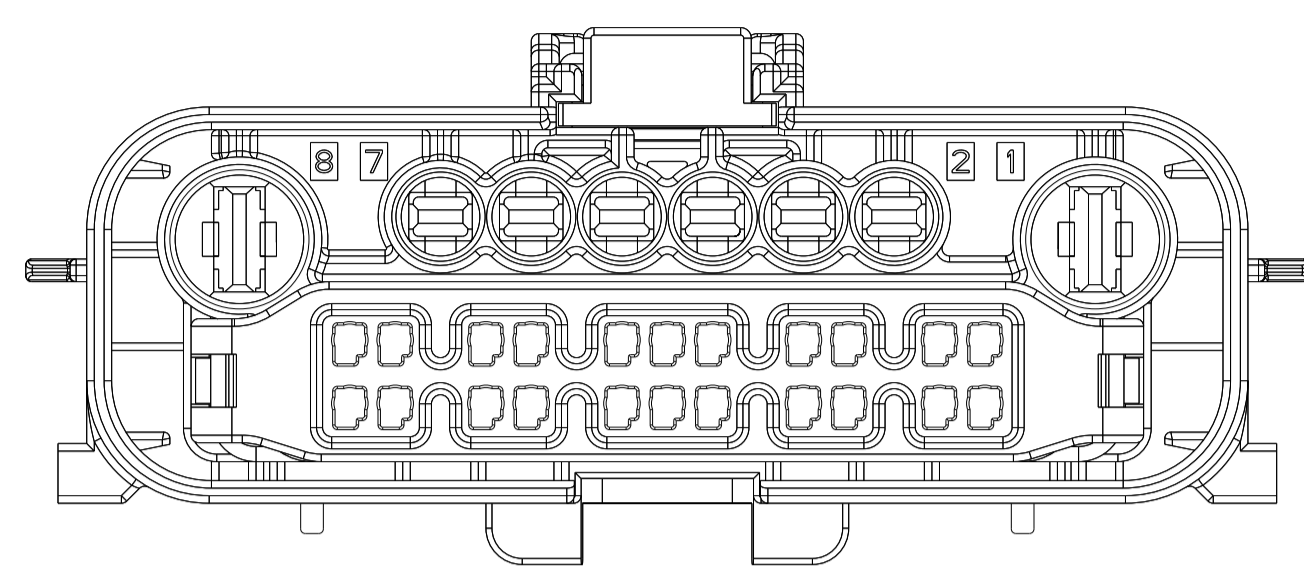

2301461-1  
KEY A - BLACK

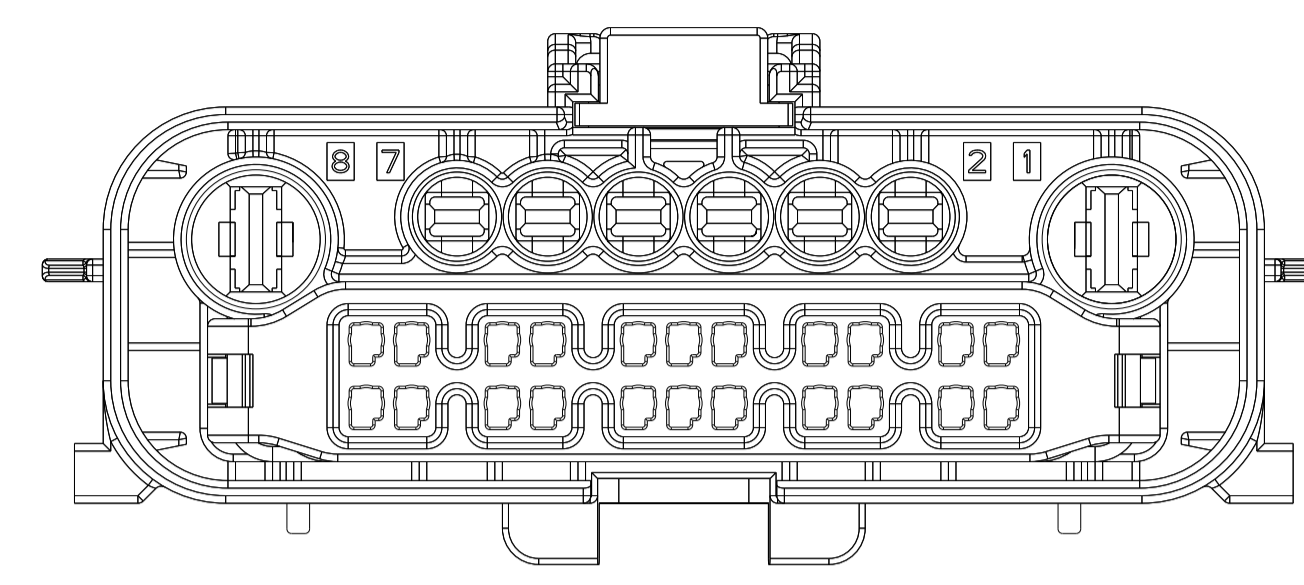

2301461-2  
KEY B - LT GRAY

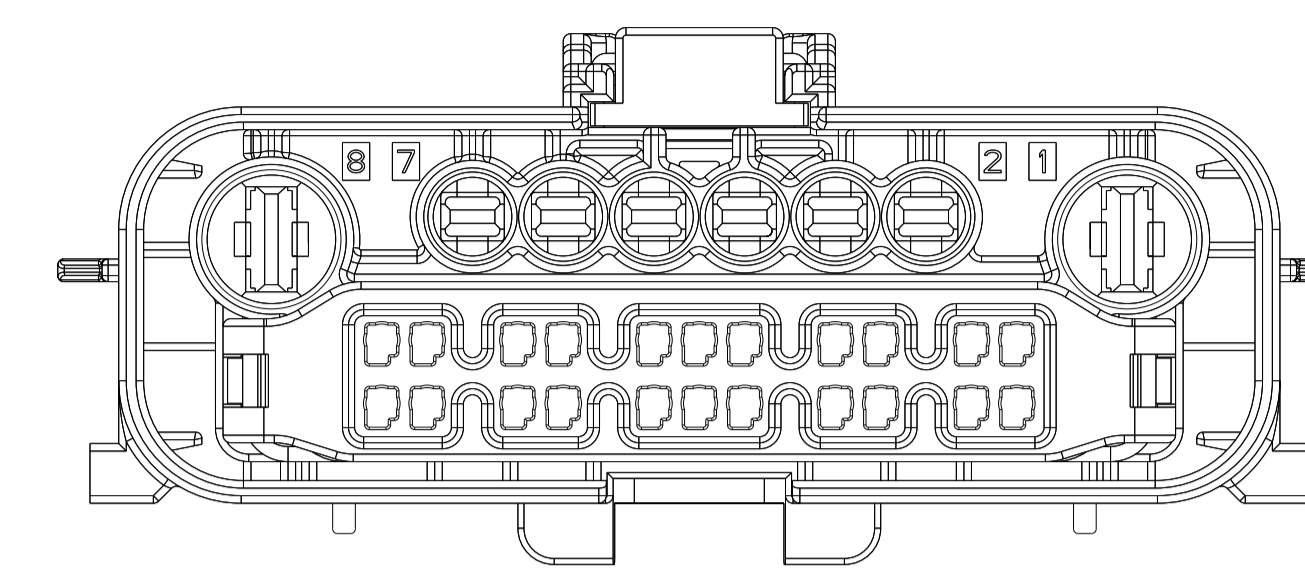

2301461-3  
KEY C - DK GRAY

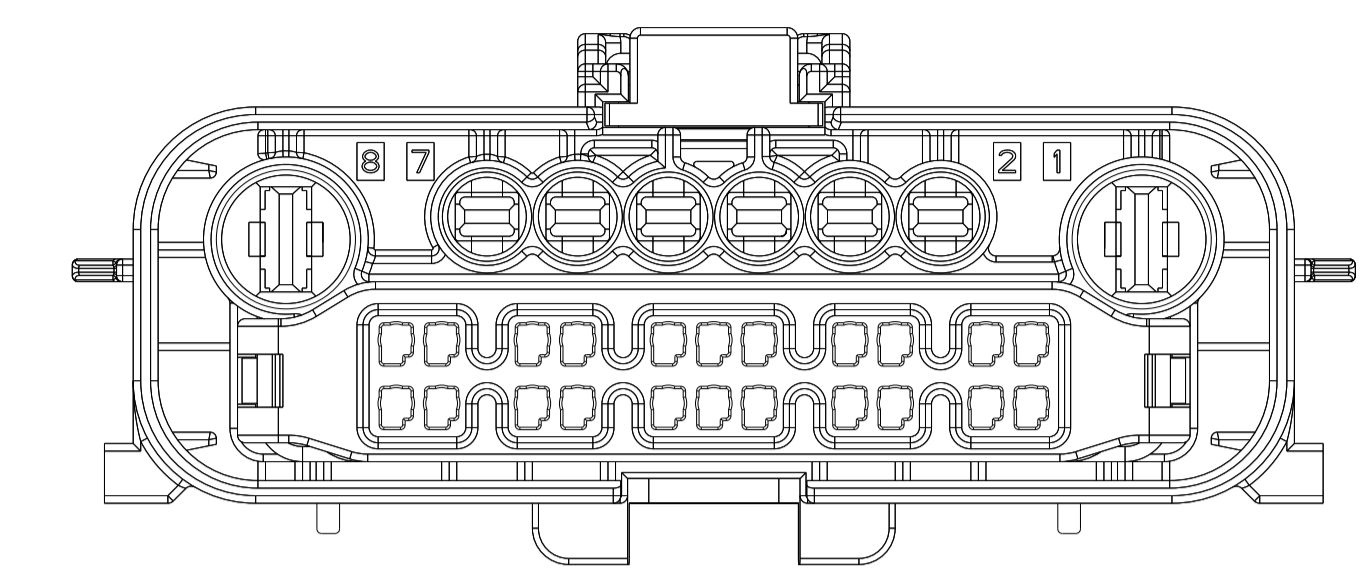

2301461-4  
KEY D - BLACK

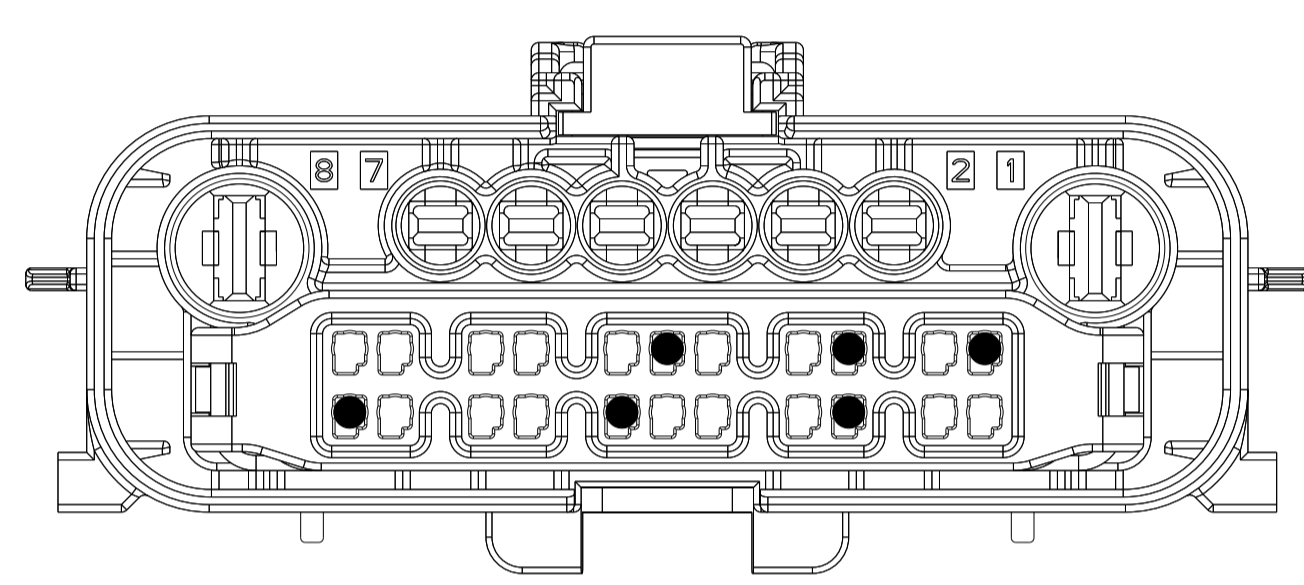

2301461-5  
KEY A - BLACK

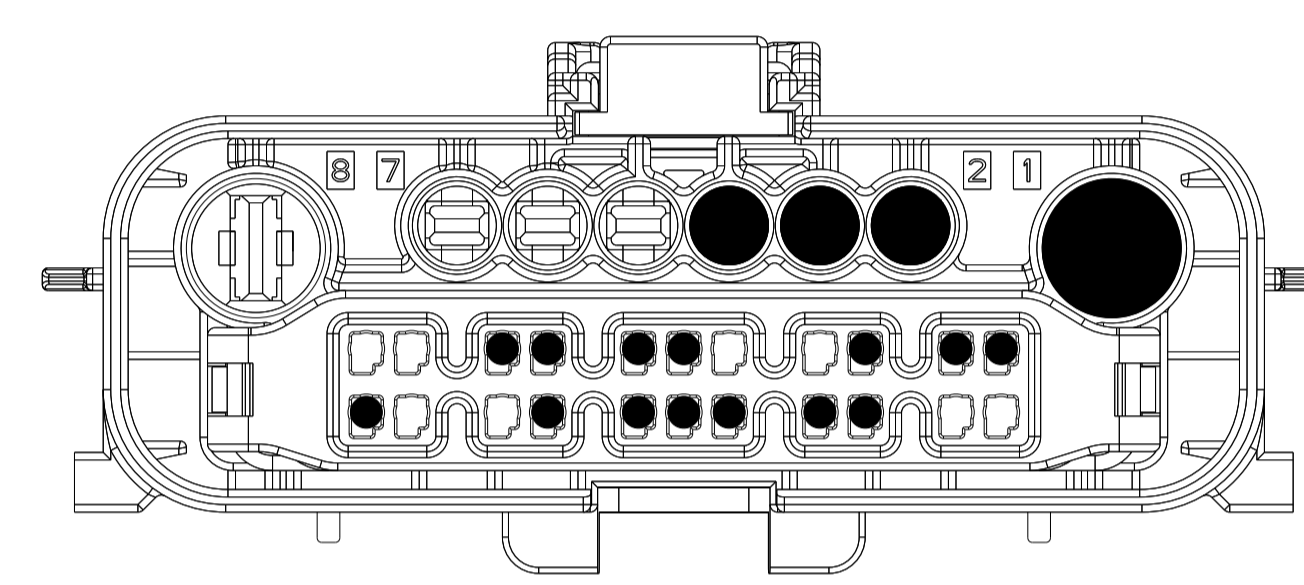

2301461-6  
KEY A - BLACK

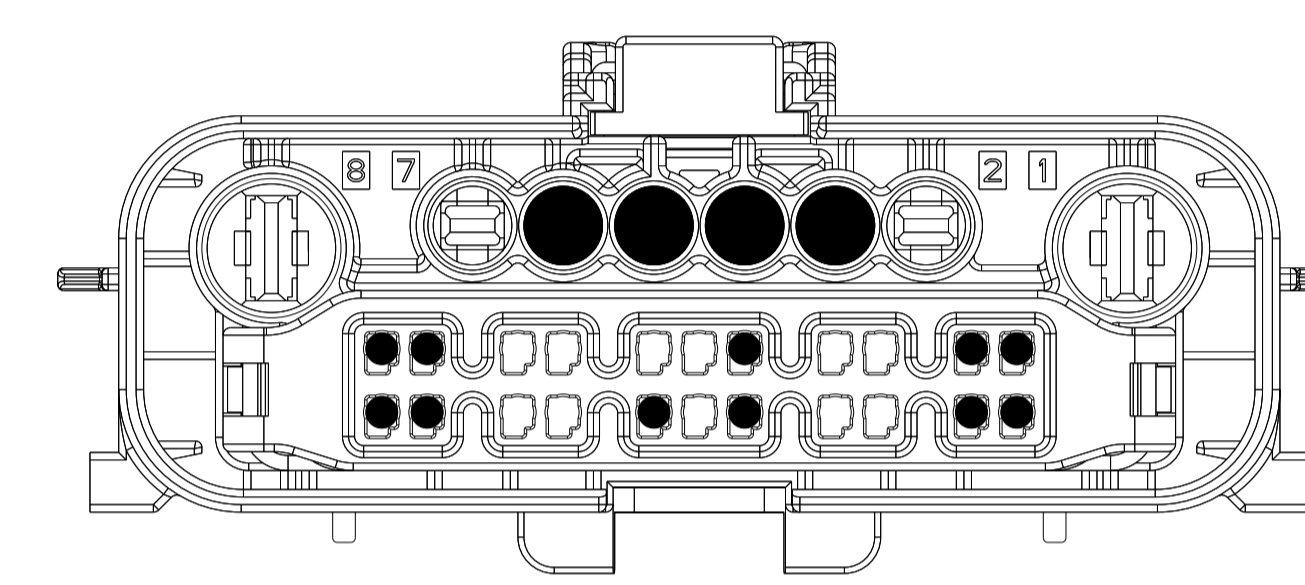

2301461-7  
KEY A - BLACK

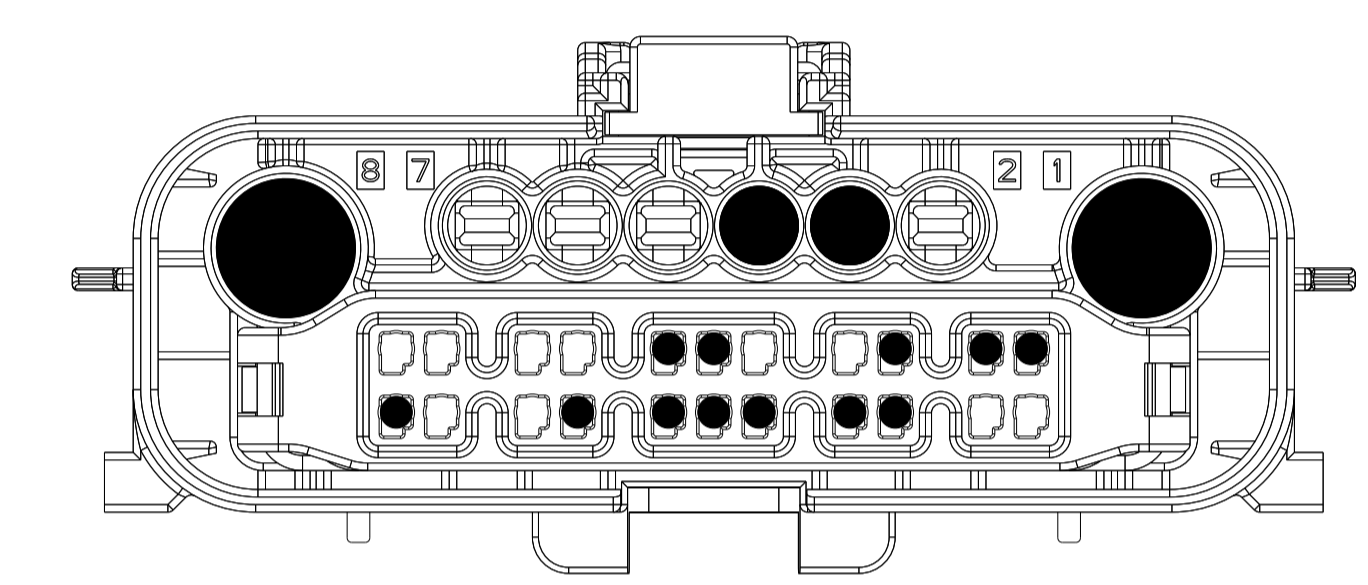

2301461-8  
KEY A - BLACK

CIRCUITS WITH SHADED CIRCLES ARE BLOCKED

| TOOLING STATUS | TERMINAL HOLE POSITION |    |    |    |    |    |    |    |    |    |    |    |    |    |    |    |    |    |    |    |    |   |   |   |   |   |   |   |   |   | COLOR | KEY | ASSEMBLY PART # |         |   |           |
|----------------|------------------------|----|----|----|----|----|----|----|----|----|----|----|----|----|----|----|----|----|----|----|----|---|---|---|---|---|---|---|---|---|-------|-----|-----------------|---------|---|-----------|
|                | 30                     | 29 | 28 | 27 | 26 | 25 | 24 | 23 | 22 | 21 | 20 | 19 | 18 | 17 | 16 | 15 | 14 | 13 | 12 | 11 | 10 | 9 | 8 | 7 | 6 | 5 | 4 | 3 | 2 | 1 |       |     |                 |         |   |           |
| TOOLED         | 30                     |    |    |    |    |    |    |    |    |    |    |    |    |    |    |    |    |    |    |    |    |   |   |   |   |   |   |   |   |   |       |     |                 | BLACK   | A | 2301461-8 |
| TOOLED         | 30                     | 29 |    |    |    |    |    |    |    |    |    |    |    |    |    |    |    |    |    |    |    |   |   |   |   |   |   |   |   |   |       |     |                 | BLACK   | A | 2301461-7 |
| TOOLED         | 30                     |    |    |    |    |    |    |    |    |    |    |    |    |    |    |    |    |    |    |    |    |   |   |   |   |   |   |   |   |   |       |     |                 | BLACK   | A | 2301461-6 |
| TOOLED         | 30                     |    |    |    |    |    |    |    |    |    |    |    |    |    |    |    |    |    |    |    |    |   |   |   |   |   |   |   |   |   |       |     |                 | BLACK   | A | 2301461-5 |
| TOOLED         |                        |    |    |    |    |    |    |    |    |    |    |    |    |    |    |    |    |    |    |    |    |   |   |   |   |   |   |   |   |   |       |     |                 | BLACK   | D | 2301461-4 |
| TOOLED         |                        |    |    |    |    |    |    |    |    |    |    |    |    |    |    |    |    |    |    |    |    |   |   |   |   |   |   |   |   |   |       |     |                 | DK GRAY | C | 2301461-3 |
| TOOLED         |                        |    |    |    |    |    |    |    |    |    |    |    |    |    |    |    |    |    |    |    |    |   |   |   |   |   |   |   |   |   |       |     |                 | LT GRAY | B | 2301461-2 |
| TOOLED         |                        |    |    |    |    |    |    |    |    |    |    |    |    |    |    |    |    |    |    |    |    |   |   |   |   |   |   |   |   |   |       |     |                 | BLACK   | A | 2301461-1 |

CAVITIES WITH A NUMERIC SYMBOL INDICATES CLOSED TERMINAL LOCATION  
 BLANK CAVITIES INDICATES OPEN TERMINAL HOLE LOCATIONS

PIN OUT CHART

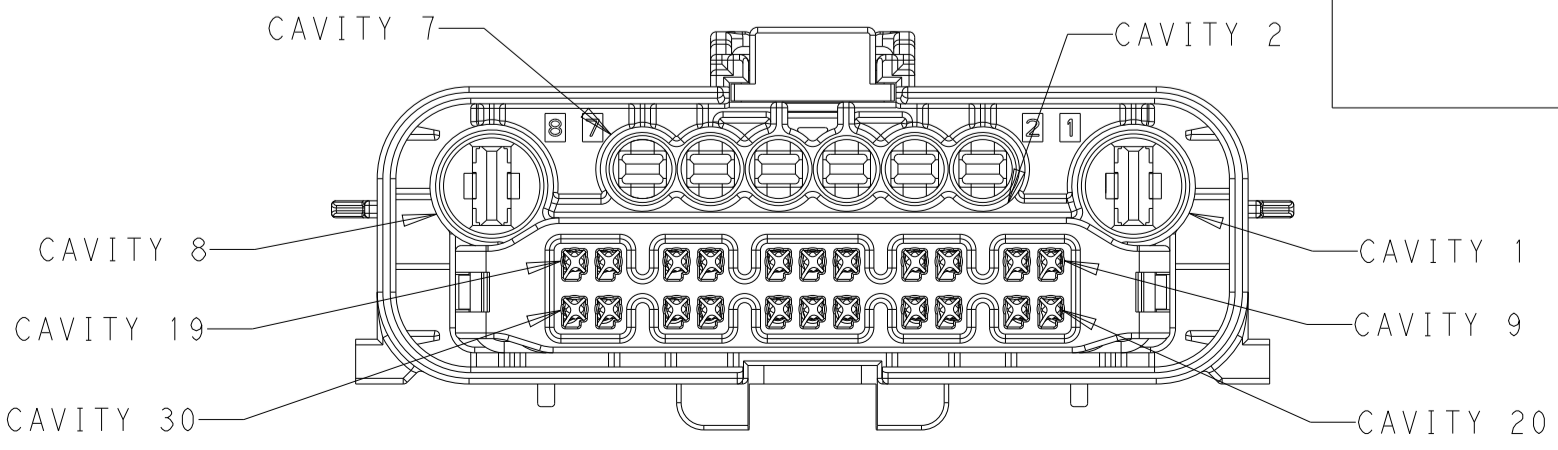

THIS DRAWING IS A CONTROLLED DOCUMENT. **STE** TE Connectivity

|                  |  |                           |                           |                            |                                      |
|------------------|--|---------------------------|---------------------------|----------------------------|--------------------------------------|
| DIMENSIONS: mm   | TOLERANCES UNLESS OTHERWISE SPECIFIED: | OWN: R. HETRICK 18APR2016 | CHK: R. HETRICK 18APR2016 | APVD: R. HETRICK 18APR2016 | NAME: 30P SEALED HYBRID CAP ASSEMBLY |
| 0 PLC ±0.5       | 1 PLC ±0.3                             | 2 PLC ±0.3                | 3 PLC ±0.3                | 4 PLC ±0.3                 | APPLICATION SPEC                     |
| ANGLES FINISH    | ±3°                                    | WEIGHT                    | SIZE: A1                  | CAGE CODE: -               | DRAWING NO: C=2301461                |
| CUSTOMER DRAWING |  |                           | SCALE: 3:2                | SHEET: 2 OF 5              | REV: C15                             |

| REVISIONS |     |             |      |      |
|-----------|-----|-------------|------|------|
| P         | LTN | DESCRIPTION | DATE | APVD |
| -         | -   | SEE SHEET 1 | -    | -    |
| -         | -   | -           | -    | -    |
| -         | -   | -           | -    | -    |

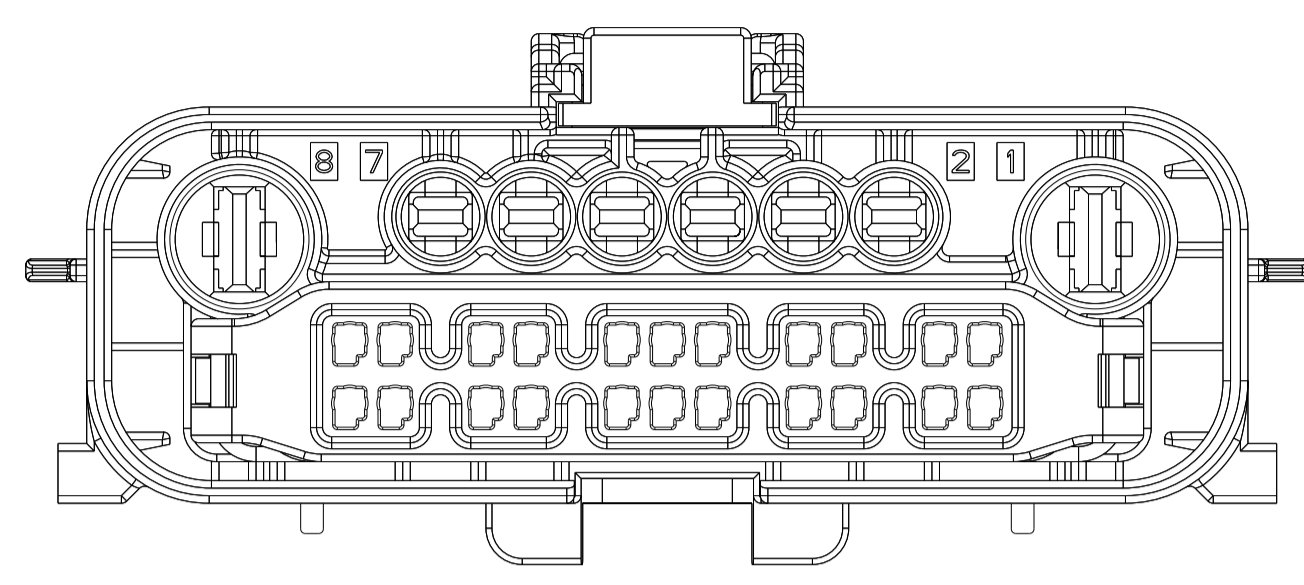

2301461-9  
KEY A - YELLOW

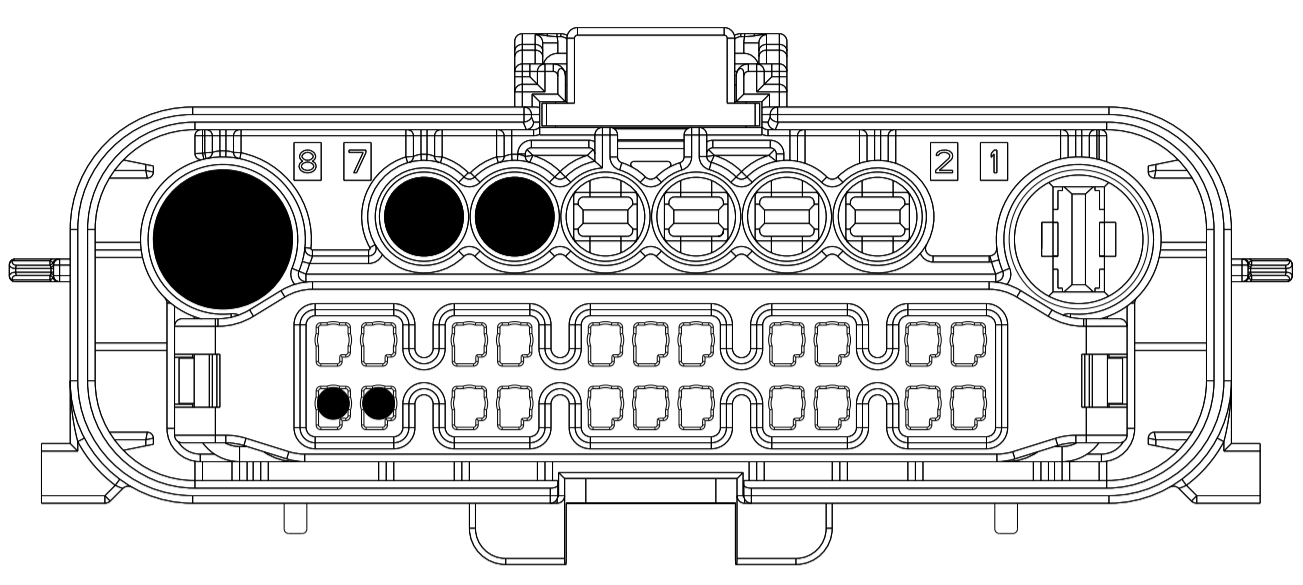

1-2301461-0  
KEY A - YELLOW

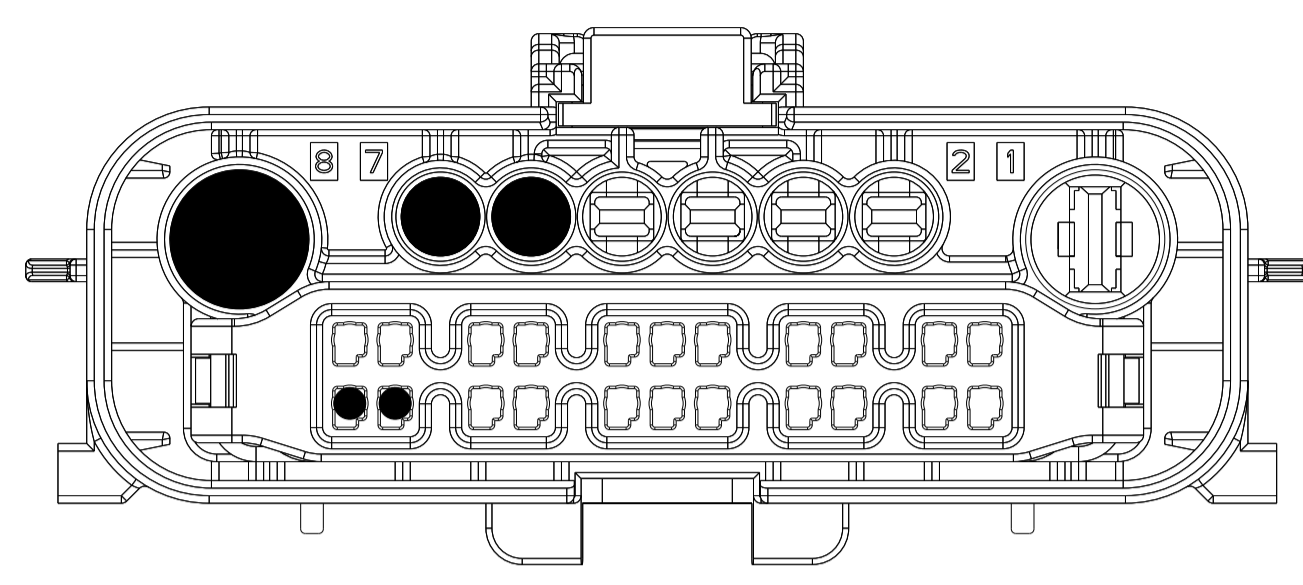

1-2301461-1  
KEY A - BLACK

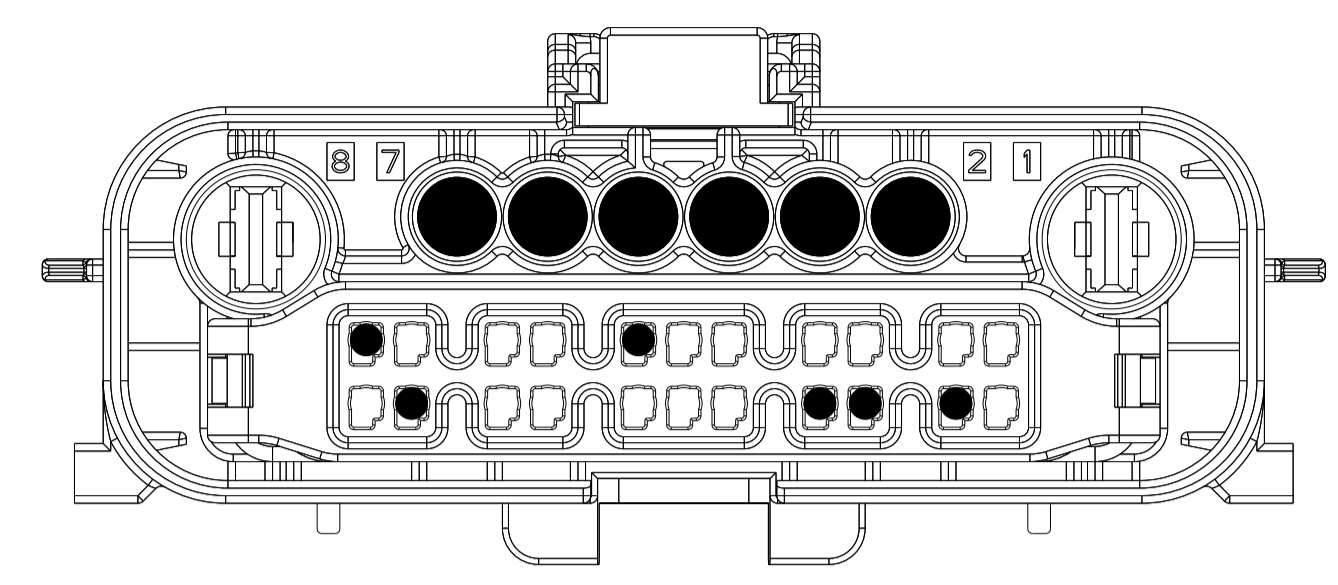

1-2301461-2  
KEY A - BLACK

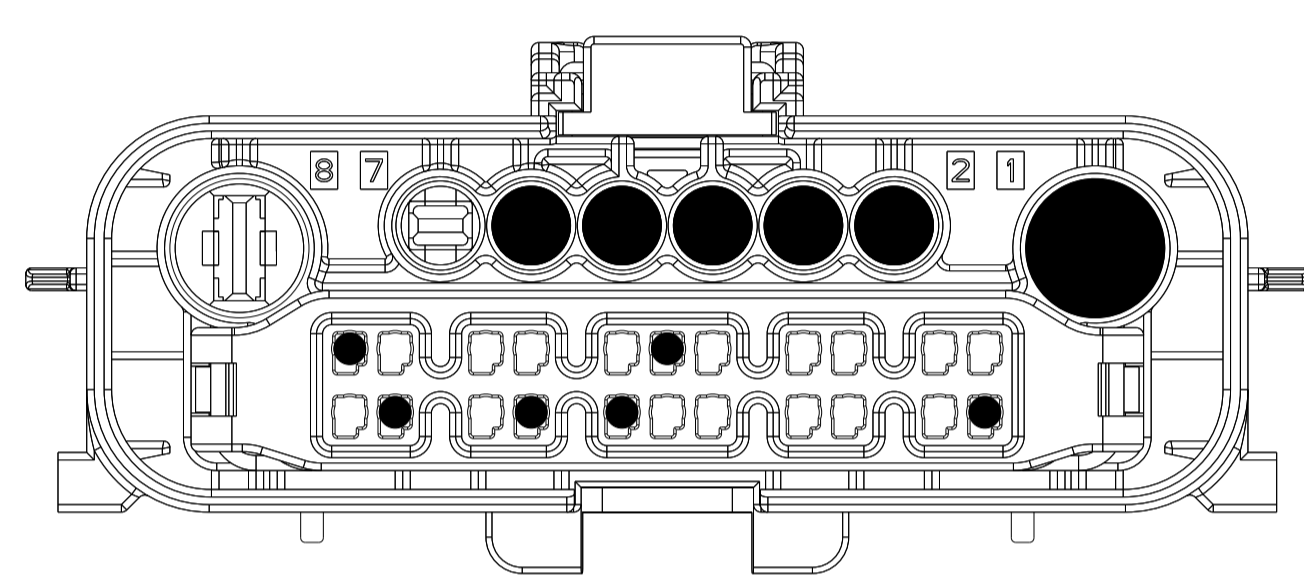

1-2301461-3  
KEY A - BLACK

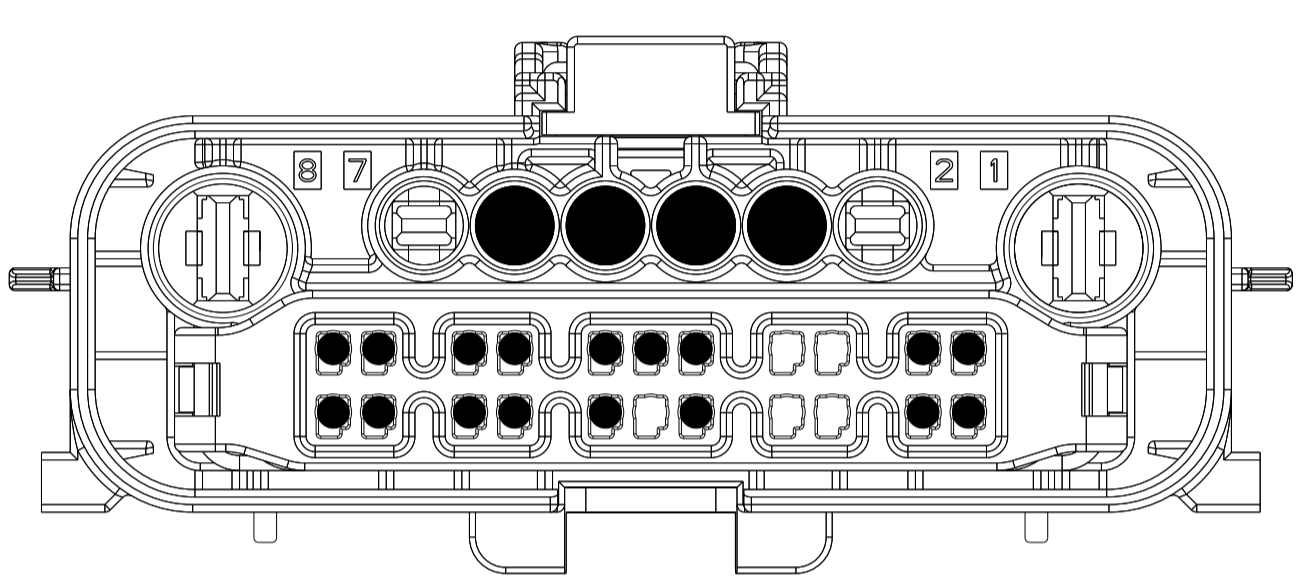

1-2301461-4  
KEY B - LT GRAY

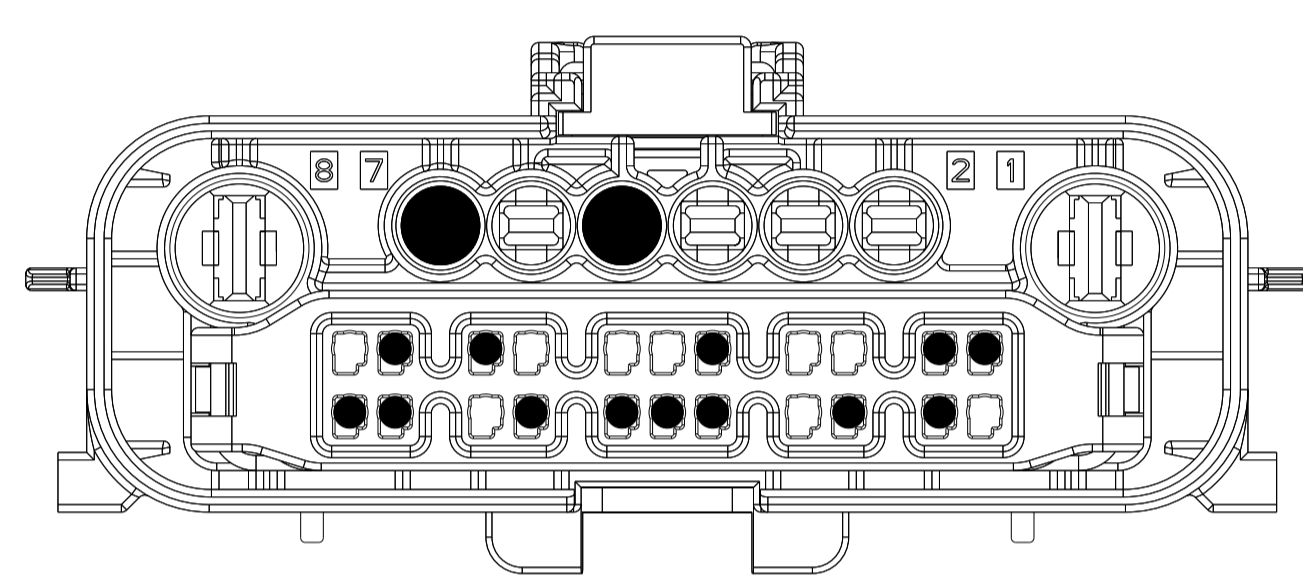

1-2301461-5  
KEY A - BLACK

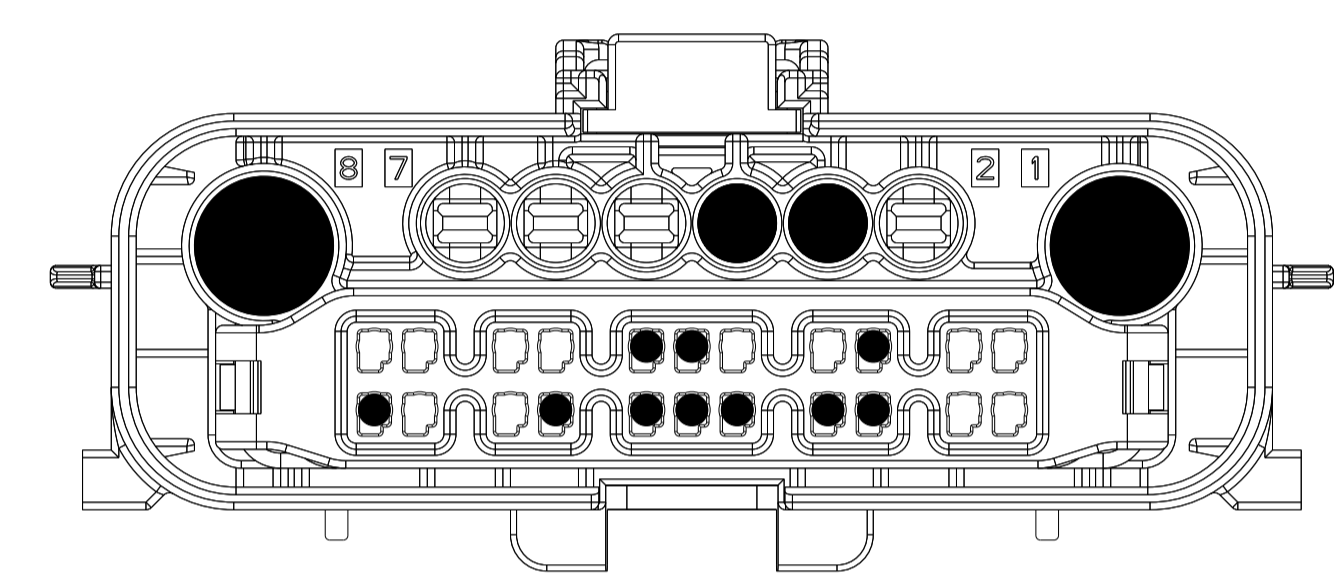

1-2301461-6  
KEY A - BLACK

CIRCUITS WITH SHADED CIRCLES ARE BLOCKED

| TOOLING STATUS | 30 | 29 | 28 | 27 | 26 | 25 | 24 | 23 | 22 | 21 | 20 | 19 | 18 | 17 | 16 | 15 | 14 | 13 | 12 | 11 | 10 | 9 | 8 | 7 | 6 | 5 | 4 | 3 | 2 | 1 | COLOR | KEY     | ASSEMBLY PART # |             |
|----------------|----|----|----|----|----|----|----|----|----|----|----|----|----|----|----|----|----|----|----|----|----|---|---|---|---|---|---|---|---|---|-------|---------|-----------------|-------------|
| TOOLED         |    |    |    |    |    |    |    |    |    |    |    |    |    |    |    |    |    |    |    |    |    |   |   |   |   |   |   |   |   |   |       | BLACK   | A               | 1-2301461-6 |
| TOOLED         |    |    |    |    |    |    |    |    |    |    |    |    |    |    |    |    |    |    |    |    |    |   |   |   |   |   |   |   |   |   |       | BLACK   | A               | 1-2301461-5 |
| TOOLED         |    |    |    |    |    |    |    |    |    |    |    |    |    |    |    |    |    |    |    |    |    |   |   |   |   |   |   |   |   |   |       | LT GRAY | B               | 1-2301461-4 |
| TOOLED         |    |    |    |    |    |    |    |    |    |    |    |    |    |    |    |    |    |    |    |    |    |   |   |   |   |   |   |   |   |   |       | BLACK   | A               | 1-2301461-3 |
| TOOLED         |    |    |    |    |    |    |    |    |    |    |    |    |    |    |    |    |    |    |    |    |    |   |   |   |   |   |   |   |   |   |       | BLACK   | A               | 1-2301461-2 |
| TOOLED         |    |    |    |    |    |    |    |    |    |    |    |    |    |    |    |    |    |    |    |    |    |   |   |   |   |   |   |   |   |   |       | BLACK   | A               | 1-2301461-1 |
| TOOLED         |    |    |    |    |    |    |    |    |    |    |    |    |    |    |    |    |    |    |    |    |    |   |   |   |   |   |   |   |   |   |       | YELLOW  | A               | 1-2301461-0 |
| TOOLED         |    |    |    |    |    |    |    |    |    |    |    |    |    |    |    |    |    |    |    |    |    |   |   |   |   |   |   |   |   |   |       | YELLOW  | A               | 2301461-9   |

TOOLING STATUS

TERMINAL HOLE POSITION  
 CAVITIES WITH A NUMERIC SYMBOL INDICATES CLOSED TERMINAL LOCATION  
 BLANK CAVITIES INDICATES OPEN TERMINAL HOLE LOCATIONS

PIN OUT CHART

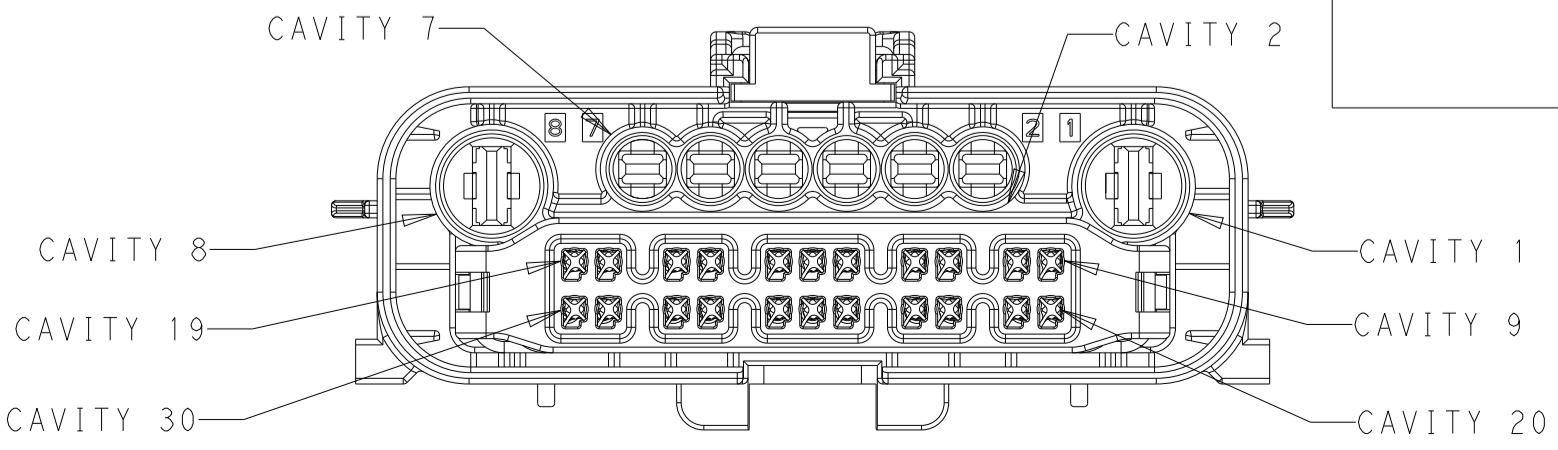

THIS DRAWING IS A CONTROLLED DOCUMENT. DWN: R. HETRICK 18APR2016  
 CHK: R. HETRICK 18APR2016  
 APVD: R. HETRICK 18APR2016

TE Connectivity

NAME: 30P SEALED HYBRID CAP ASSEMBLY

SIZE: A1 CAGE CODE: - DRAWING NO: C=2301461 RESTRICTED TO: -

CUSTOMER DRAWING SCALE: 3:2 SHEET 3 OF 5 REV: C15

TOLERANCES UNLESS OTHERWISE SPECIFIED:  
 DIMENSIONS: mm  
 0 PLC ±0.5  
 1 PLC ±0.3  
 2 PLC ±0.3  
 3 PLC ±0.3  
 4 PLC ±0.3  
 ANGLES FINISH ±3°



| REVISIONS |     |             |      |      |
|-----------|-----|-------------|------|------|
| P         | LTN | DESCRIPTION | DATE | APVD |
| -         | -   | SEE SHEET 1 | -    | -    |
| -         | -   | -           | -    | -    |
| -         | -   | -           | -    | -    |

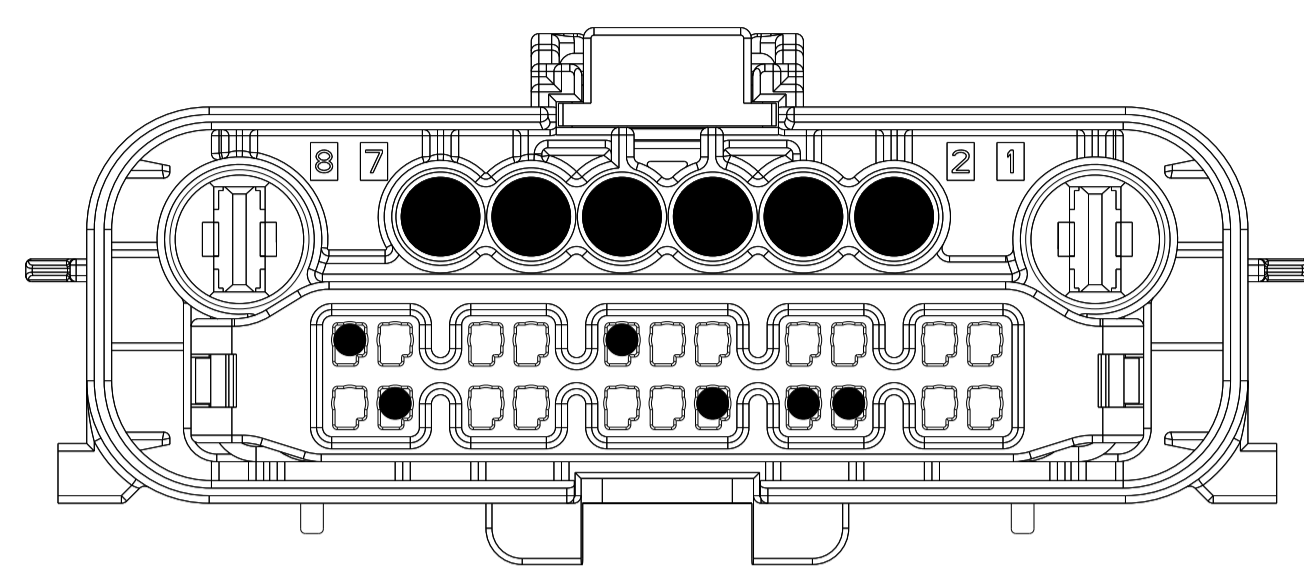

1-2301461-7  
KEY A - BLACK

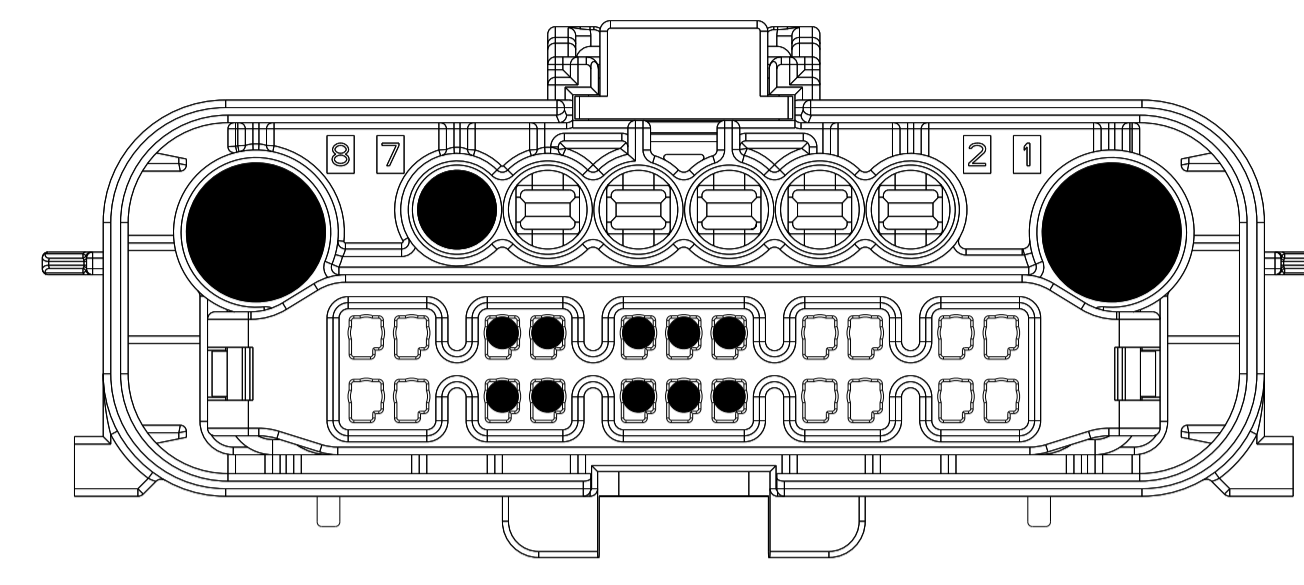

1-2301461-8  
KEY A - BLACK

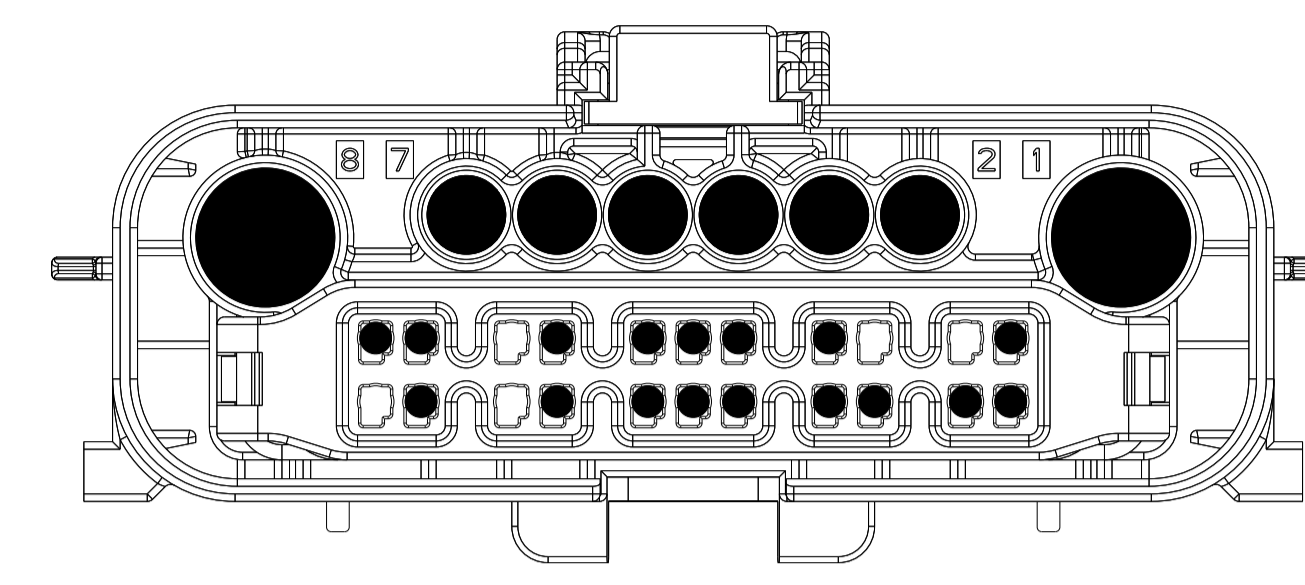

1-2301461-9  
KEY A - BLACK

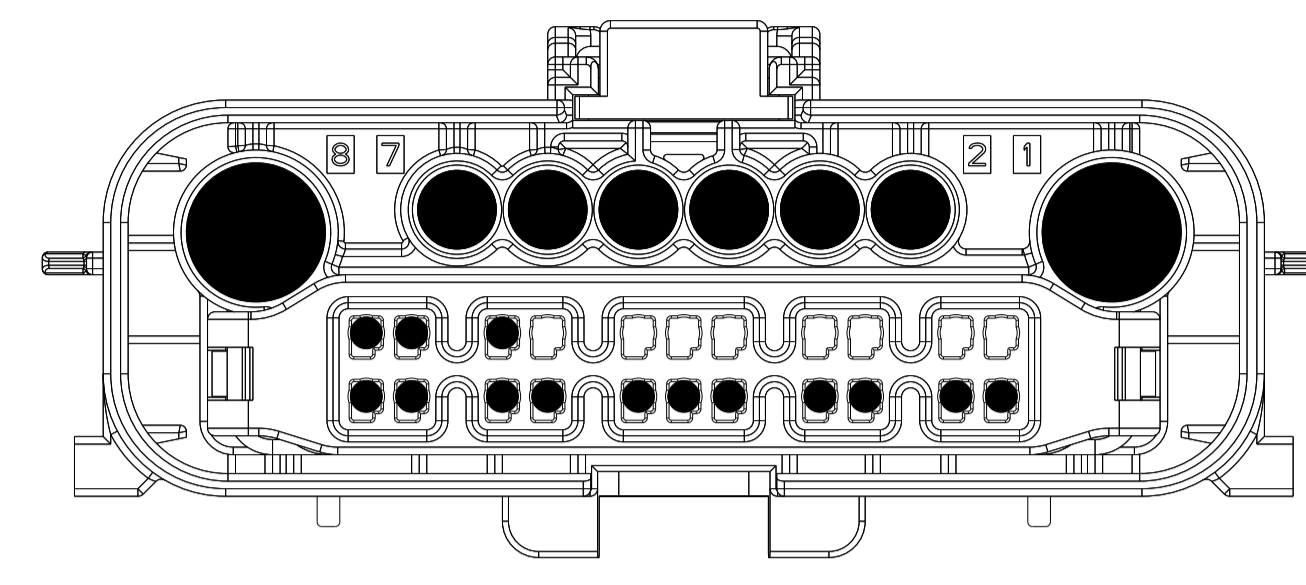

2-2301461-0  
KEY A - BLACK

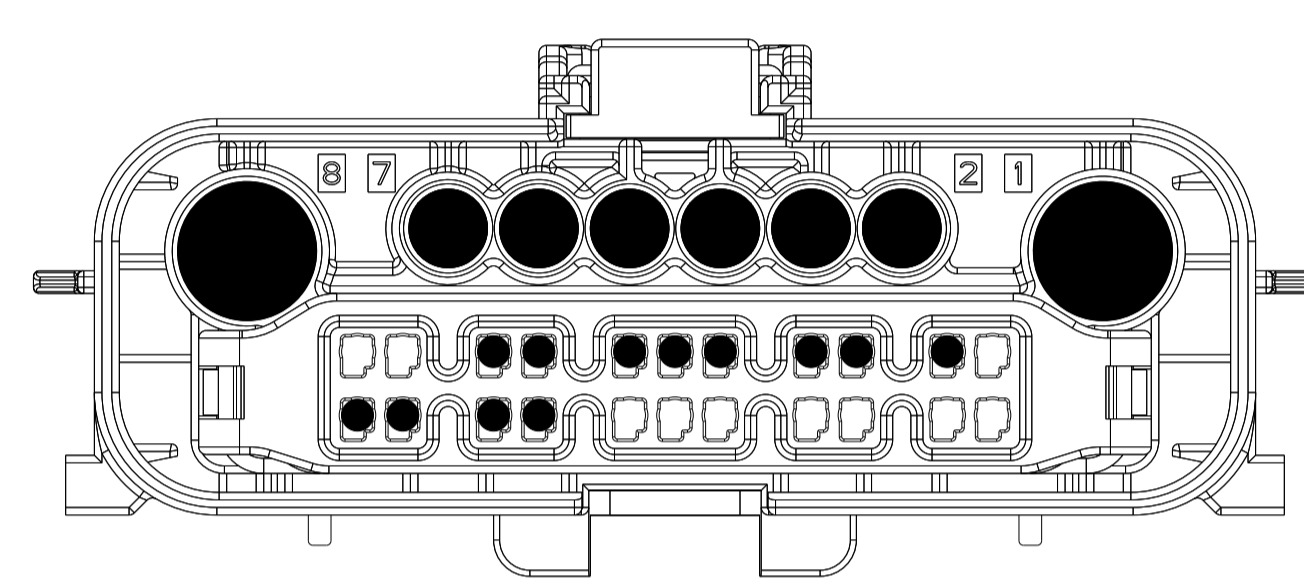

2-2301461-1  
KEY A - BLACK

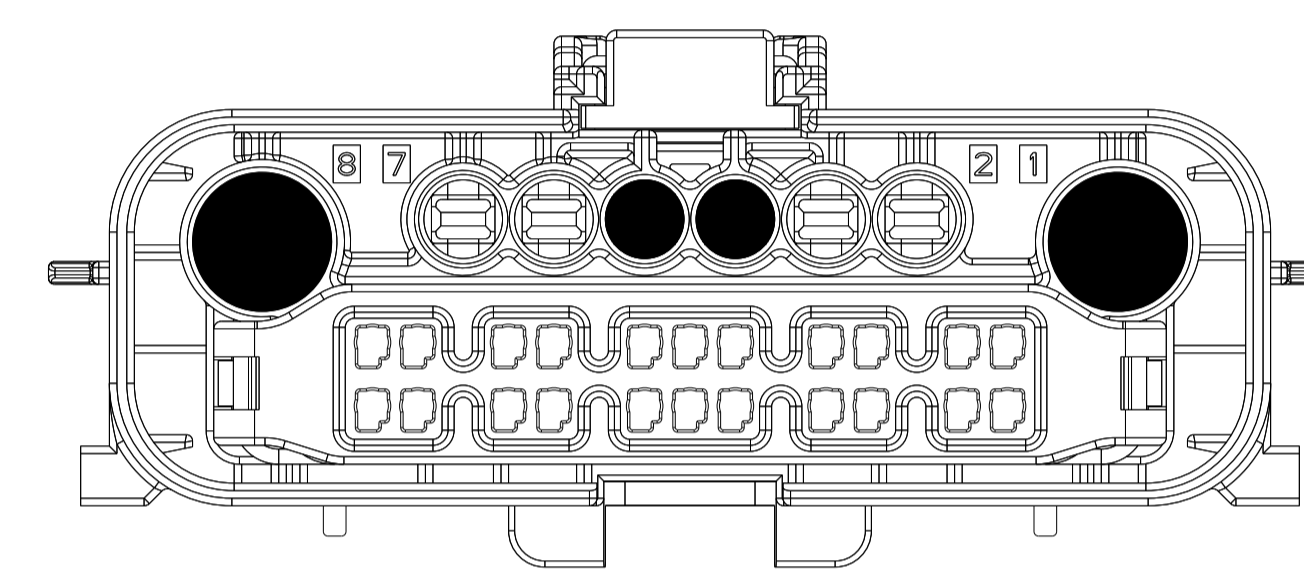

2-2301461-2  
KEY A - BLACK

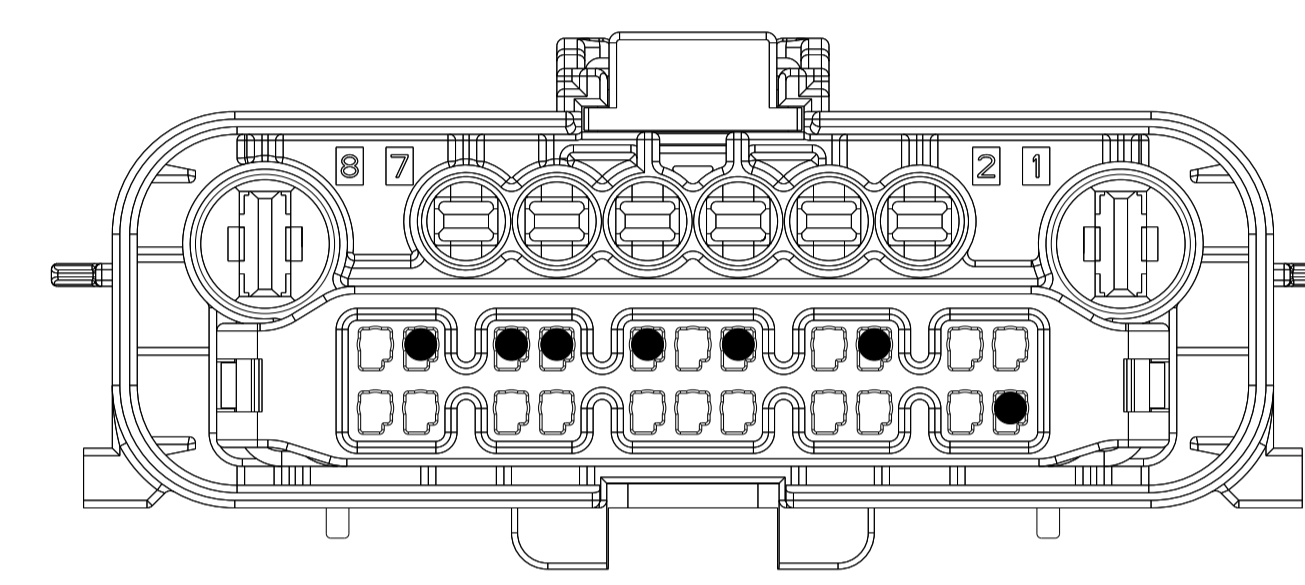

2-2301461-3  
KEY A - BLACK

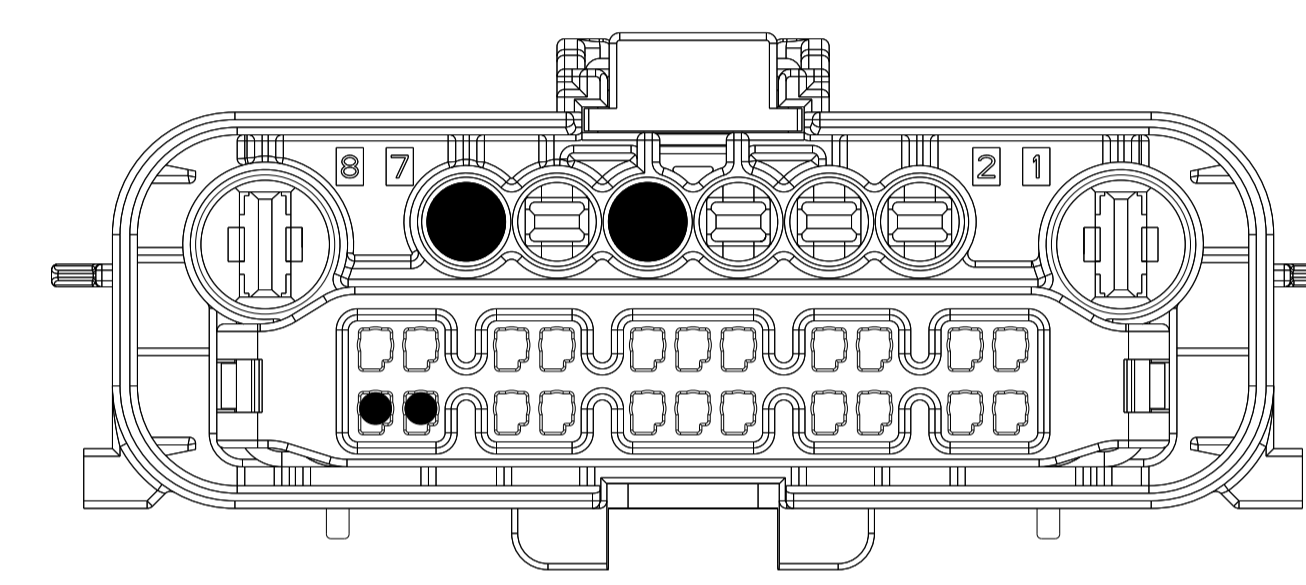

2-2301461-4  
KEY A - BLACK

CIRCUITS WITH SHADED CIRCLES ARE BLOCKED

| TOOLING STATUS | 30 | 29 | 28 | 27 | 26 | 25 | 24 | 23 | 22 | 21 | 20 | 19 | 18 | 17 | 16 | 15 | 14 | 13 | 12 | 11 | 10 | 9 | 8 | 7 | 6 | 5 | 4 | 3 | 2 | 1     | COLOR | KEY         | ASSEMBLY PART # |
|----------------|----|----|----|----|----|----|----|----|----|----|----|----|----|----|----|----|----|----|----|----|----|---|---|---|---|---|---|---|---|-------|-------|-------------|-----------------|
| TOOLED         |    |    |    |    |    |    |    |    |    |    |    |    |    |    |    |    |    |    |    |    |    |   |   | 7 | 5 |   |   |   |   |       | BLACK | A           | 2-2301461-4     |
| TOOLED         |    |    |    |    |    |    |    |    |    |    | 20 | 18 | 17 | 16 | 15 |    |    | 13 | 11 |    |    |   |   |   |   |   |   |   |   |       | BLACK | A           | 2-2301461-3     |
| TOOLED         |    |    |    |    |    |    |    |    |    |    |    |    |    |    |    |    |    |    |    |    |    |   | 8 |   | 5 | 4 |   |   | 1 | BLACK | A     | 2-2301461-2 |                 |
| TOOLED         | 30 | 29 | 28 | 27 |    |    |    |    |    |    |    |    |    | 17 | 16 | 15 | 14 | 13 | 12 | 11 | 10 |   | 8 | 7 | 6 | 5 | 4 | 3 | 2 | 1     | BLACK | A           | 2-2301461-1     |
| TOOLED         | 30 | 29 | 28 | 27 | 26 | 25 | 24 | 23 | 22 | 21 | 20 | 19 | 18 | 17 |    |    |    |    |    |    |    |   | 8 | 7 | 6 | 5 | 4 | 3 | 2 | 1     | BLACK | A           | 2-2301461-0     |
| TOOLED         |    | 29 |    | 27 | 26 | 25 | 24 | 23 | 22 | 21 | 20 | 19 | 18 |    | 16 | 15 | 14 | 13 | 12 |    |    | 9 | 8 | 7 | 6 | 5 | 4 | 3 | 2 | 1     | BLACK | A           | 1-2301461-9     |
| TOOLED         |    |    | 28 | 27 | 26 | 25 | 24 |    |    |    |    |    |    | 17 | 16 | 15 | 14 | 13 |    |    |    |   | 8 | 7 |   |   |   |   |   | 1     | BLACK | A           | 1-2301461-8     |
| TOOLED         |    | 29 |    |    |    | 24 | 23 | 22 |    |    | 19 |    |    |    | 15 |    |    |    |    |    |    |   | 7 | 6 | 5 | 4 | 3 | 2 |   |       | BLACK | A           | 1-2301461-7     |
|                | 30 | 29 | 28 | 27 | 26 | 25 | 24 | 23 | 22 | 21 | 20 | 19 | 18 | 17 | 16 | 15 | 14 | 13 | 12 | 11 | 10 | 9 | 8 | 7 | 6 | 5 | 4 | 3 | 2 | 1     |       |             |                 |

TERMINAL HOLE POSITION  
 CAVITIES WITH A NUMERIC SYMBOL INDICATES CLOSED TERMINAL LOCATION  
 BLANK CAVITIES INDICATES OPEN TERMINAL HOLE LOCATIONS

PIN OUT CHART

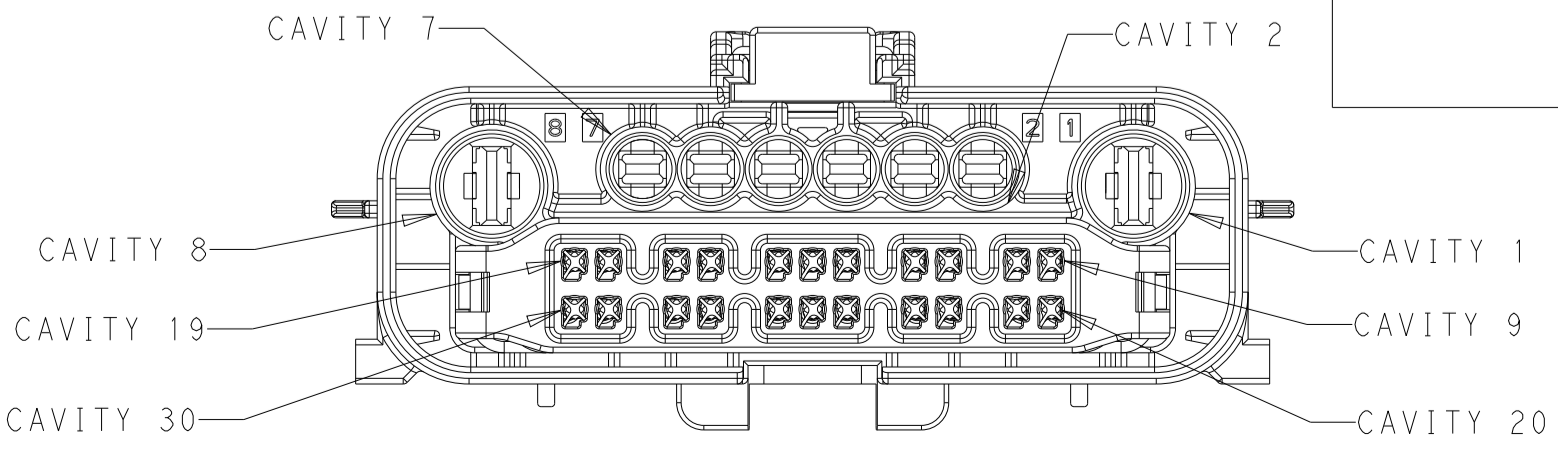

THIS DRAWING IS A CONTROLLED DOCUMENT. OWN: R. HETRICK 18APR2016  
 CHK: R. HETRICK 18APR2016  
 APVD: R. HETRICK 18APR2016

TE Connectivity

NAME: 30P SEALED HYBRID CAP ASSEMBLY

SIZE: A1 CAGE CODE: - DRAWING NO: C=2301461 RESTRICTED TO: -

SCALE: 3:2 SHEET: 4 OF 5 REV: C15

| REVISIONS |     |             |      |      |
|-----------|-----|-------------|------|------|
| P         | LTN | DESCRIPTION | DATE | APVD |
| -         | -   | SEE SHEET 1 | -    | -    |
| -         | -   | -           | -    | -    |
| -         | -   | -           | -    | -    |

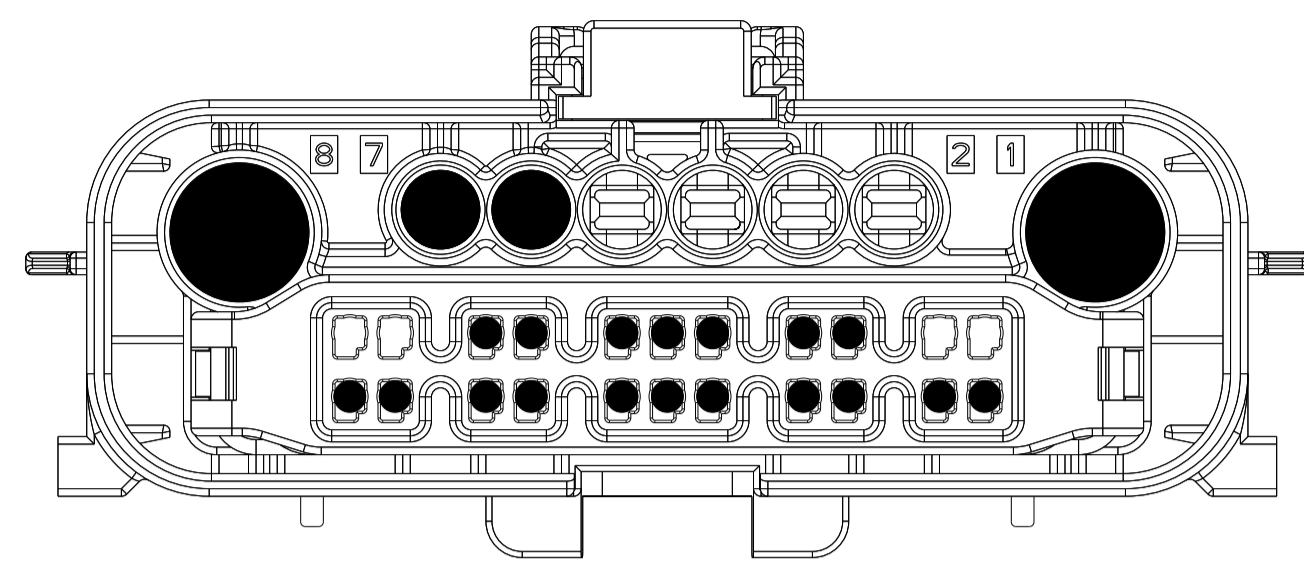

2-2301461-5  
KEY A - BLACK

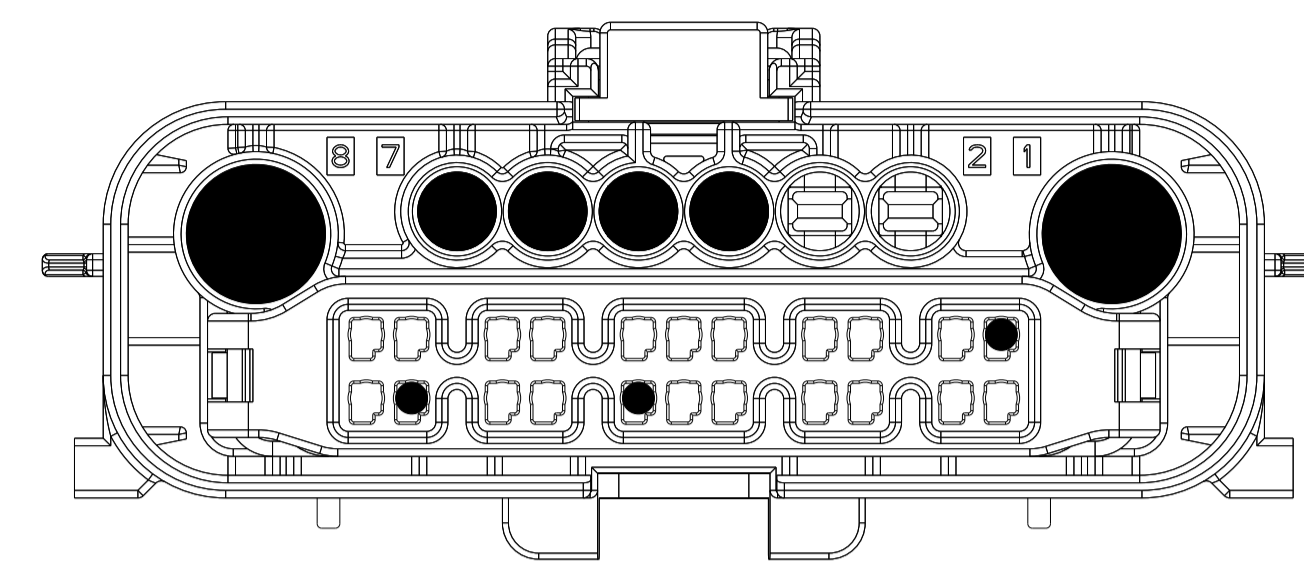

2-2301461-6  
KEY A - BLACK

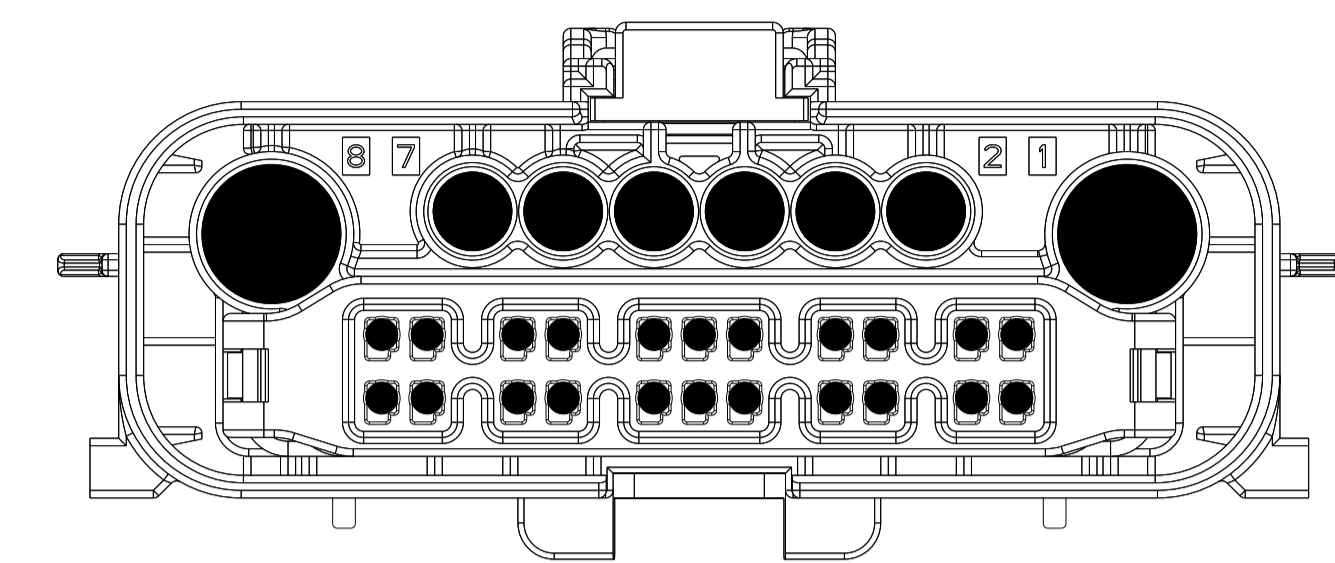

9-2301461-9  
KEY A - BLACK

CIRCUITS WITH SHADED CIRCLES ARE BLOCKED

| TOOLED   | 30 | 29 | 28 | 27 | 26 | 25 | 24 | 23 | 22 | 21 | 20 | 19 | 18 | 17 | 16 | 15 | 14    | 13  | 12              | 11 | 10 | 9 | 8 | 7 | 6 | 5 | 4 | 3 | 2 | 1 | COLOR | KEY   | ASSEMBLY PART # |             |
|--|----|----|----|----|----|----|----|----|----|----|----|----|----|----|----|----|-------|-----|-----------------|----|----|---|---|---|---|---|---|---|---|---|-------|-------|-----------------|-------------|
| TOOLED   |    | 29 |    |    | 26 |    |    |    |    |    |    |    |    |    |    |    |       |     |                 |    |    | 9 | 8 | 7 | 6 | 5 | 4 |   |   | 1 | BLACK | A     | 9-2301461-9     |             |
| TOOLED   |    |    |    |    |    |    |    |    |    |    |    |    |    |    |    |    |       |     |                 |    |    |   | 9 | 8 | 7 | 6 | 5 | 4 |   |   | 1     | BLACK | A               | 2-2301461-6 |
| TOOLED   |    |    |    |    |    |    |    |    |    |    |    |    |    |    |    |    |       |     |                 |    |    |   | 8 | 7 | 6 |   |   |   |   |   | 1     | BLACK | A               | 2-2301461-5 |
| TOOLING STATUS   | 30 | 29 | 28 | 27 | 26 | 25 | 24 | 23 | 22 | 21 | 20 | 19 | 18 | 17 | 16 | 15 | 14    | 13  | 12              | 11 | 10 | 9 | 8 | 7 | 6 | 5 | 4 | 3 | 2 | 1 |       |       |                 |             |
| TERMINAL HOLE POSITION<br>CAVITIES WITH A NUMERIC SYMBOL INDICATES CLOSED TERMINAL LOCATION<br>BLANK CAVITIES INDICATES OPEN TERMINAL HOLE LOCATIONS |    |    |    |    |    |    |    |    |    |    |    |    |    |    |    |    | COLOR | KEY | ASSEMBLY PART # |    |    |   |   |   |   |   |   |   |   |   |       |       |                 |             |

PIN OUT CHART

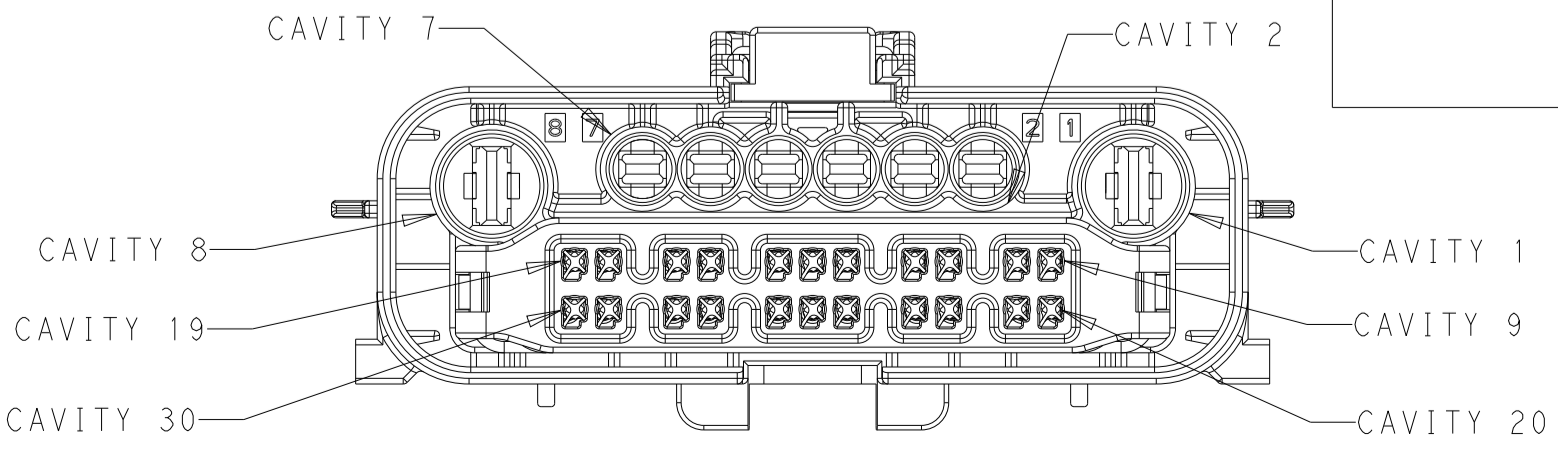

THIS DRAWING IS A CONTROLLED DOCUMENT.

|                  |   |                           |                           |                            |                                      |
|------------------|---|---------------------------|---------------------------|----------------------------|--------------------------------------|
| DIMENSIONS:      | TOLERANCES UNLESS OTHERWISE SPECIFIED:  | OWN: R. HETRICK 18APR2016 | CHK: R. HETRICK 18APR2016 | APVD: R. HETRICK 18APR2016 | NAME: 30P SEALED HYBRID CAP ASSEMBLY |
| mm               | 0 PLC ±.5<br>1 PLC ±0.5<br>2 PLC ±0.3<br>3 PLC ±.3<br>4 PLC ±.3<br>ANGLES ±3°<br>FINISH |                           |                           |                            | SIZE: A1                             |
| MATERIAL:        |   | WEIGHT:                   | CAGE CODE: -              | DRAWING NO: C=2301461      | RESTRICTED TO: -                     |
| CUSTOMER DRAWING |   | SCALE: 3:2                | SHEET: 5 OF 5             | REV: C15                   |                                      |