

# Instruction Manual for Evaluation Board of TB67H400AFTG

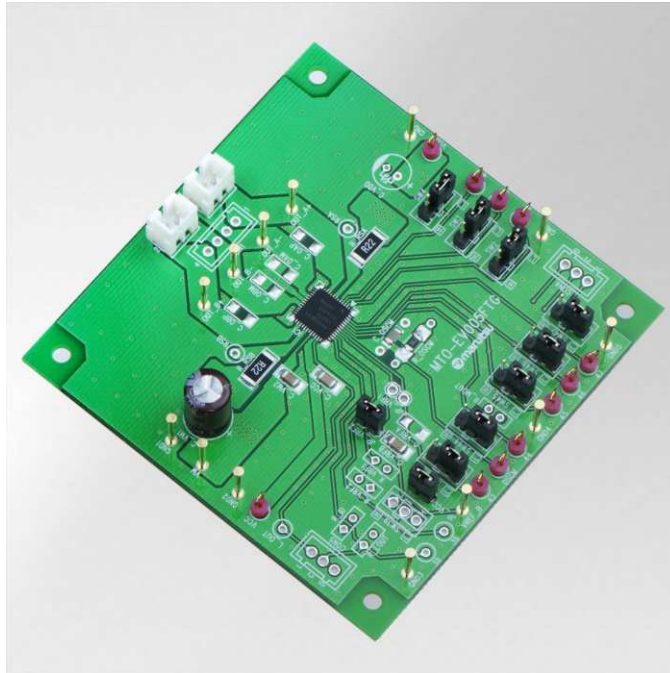

12<sup>th</sup> Sep. 2018

Rev.1.0

The TB67H400AFTG is a dual channel DC brushed Motor Driver that supports both the constant current PWM control and the direct PWM control, and is capable to control two DC brushed DC independently.

By adopting Bi-CD process, maximum Output withstand voltage of 50V and maximum Output current of 4.0A/channel as absolute maximum ratings are realized.

In addition, by using built-in parallel control function (Large mode) in output stage, one channel high current drive of 8.0A as absolute maximum rating is available.

## 【Note】

In using this device, please be careful about the thermal condition sufficiently. And for detailed operations such as control input, please refer to the datasheet and the application notes by accessing to the following URL.

<https://toshiba.semicon-storage.com/ap-en/product/linear/motordriver/detail.TB67H400AFTG.html>

Further, use of this evaluation board is strictly limited to the purpose of evaluating and learning the motor control. Please do not ship it to market.

# Basic Notes in use of this evaluation board



## Power Supply Voltage and Operating Range

In using the TB67H400AFTG, the voltage should be applied to the VM and VREF pins.

The absolute maximum rating of VM (Power supply voltage for motor) is 50V, but operating range of the power supply is 10 to 47V.

The absolute maximum rating of VREF (Reference Voltage for setting motor current) is 5V, but operating range of this voltage is 0 to 4.0V.

## Power Supply Sequence

In applying power supplies and shutting those down, no special procedures is required, because the TB67H400AFTG incorporates a error detection circuit of power-on reset (POR).

The threshold voltage of POR is designed as  $VM=8.0V\pm 1.0V$ .

However, under unstable state of VM as raising and falling, it is recommended to turn off the motor operation. Please start operation of motor by input signals after the power supplies become stable state.

## Motor Current (Output Current)

Motor current should not exceed the specified Output Current (3.0A or less).

Also, please note that the maximum current may be limited due to usage conditions (ambient temperature, heat issue, step resolution setting, etc.).

Please set to the optimum value after thermal circulation and actual evaluation under operating environment .

## Control Input

Before applying Power supplies, it is recommended that Input signals (IN1A, IN2A, IN1B, IN2B, PWMA, PWMB) are set to Low level. But even if the logic signal is inputted when VM voltage is not applied, electromotive force does not generate.

# Explanation of Each Abnormality Detection Circuit

## TSD (Thermal Shut Down)

When the junction temperature ( $T_j$ ) of this chip exceeds  $160^{\circ}\text{C}$ (typ.), a internal detection circuit starts operation and all outputs are turned off.

In the operating state of TSD, IC stays stop mode.

After TSD operation, this is canceled by turning the power supply on again or setting to standby mode once by (IN1A, IN2A, IN1B, IN2B, PWMA, PWMB=all Low) and then releasing it.

This TSD functions when the IC abnormally heats up. So that please avoid utilizing this function actively.

## ISD (Over Current Detection)

When any of current which flows in output transistors exceeds  $4.9\text{A}$ (typ.), a internal detection circuit starts operation and turns off all output transistors.

In the operating state of ISD, IC stays stop mode.

After TSD operation, this is canceled by turning the power supply on again or setting to standby mode once by (IN1A, IN2A, IN1B, IN2B, PWMA, PWMB=all Low) and then releasing it.

\* Those above values in each detection circuit are not guaranteed but reference ones.

# Connection of Evaluation Board 1 In use of Small Mode

Corresponding table of  
Silk name and Signal name

Please note that the names of silk and signal on this board are different each other as follows, because this board is designed and developed as a unfired one for H-Bridge series.

Silk name	Signal name
L_OUT	NC
38	NC
39	NC
VREFB	Vref
42	HBMODE
OSCM	OSCM
44	INA1
45	INA2
46	PWMA
47	PWMB
2	INB1
3	INB2
4	TBLKAB

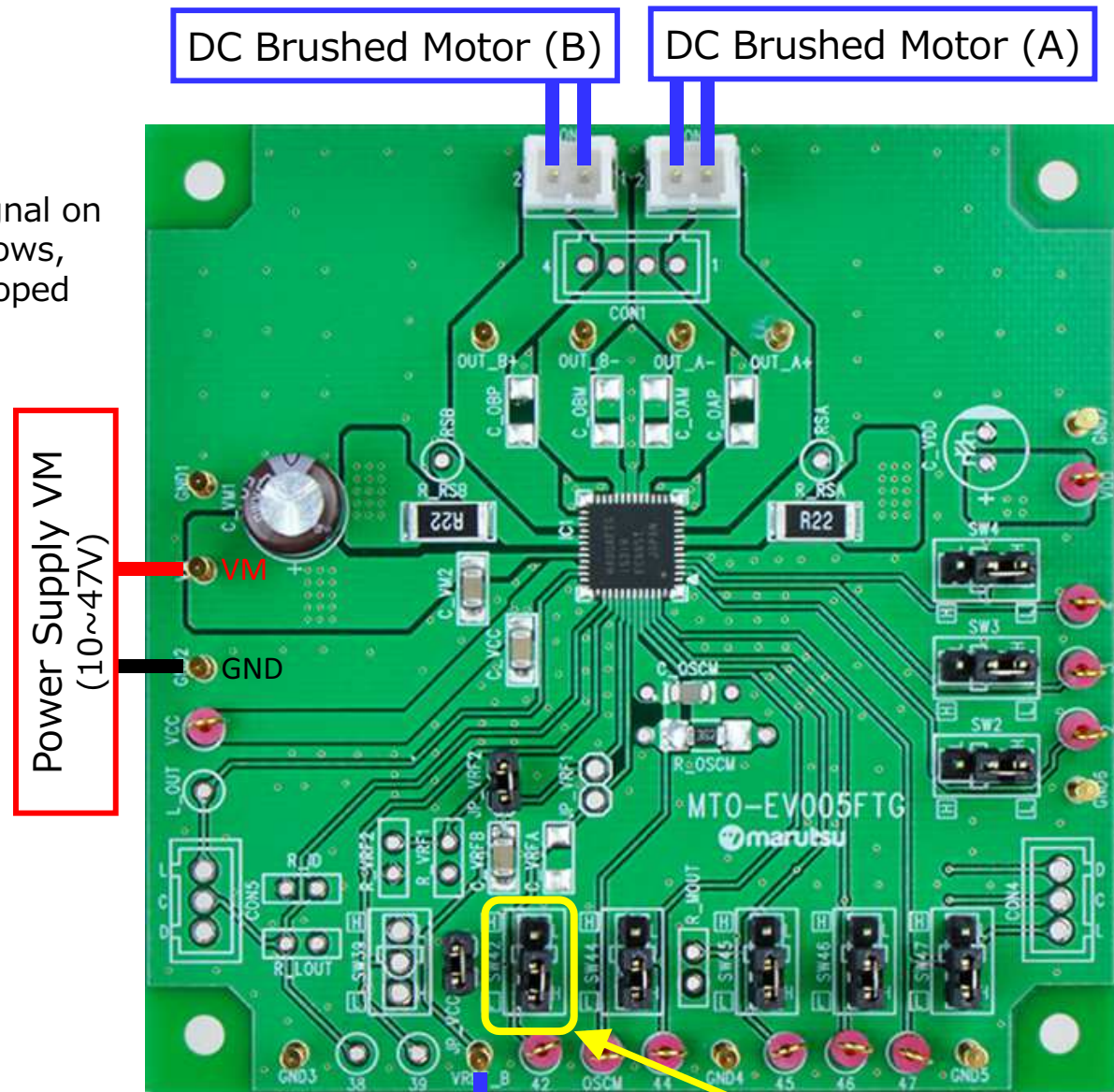

Vref (Common for A/B)

Reference Voltage for setting motor current Vref (0~4.0V)

Small mode is set by connecting this jumper of HBMODE to Low

# Connection of Evaluation Board 2 In use of Large Mode

A-ch and B-ch are connected in parallel to form one H-Bridge, and it drives one motor.

Large Mode is a parallel control function of the output part, OUTA+ and OUTA-, OUTB+ and OUTB- are tied in cascade as shown in the circuit diagram below.

In that case, the current balance of A-ch and B-ch becomes important in operation due to high current.

In use of this mode please make the following changes.

- ① Mounting the motor connector  
Please mount a connector at the two pins in the middle.
- ② Shorting of RSA terminal and RSB terminal  
By using the holes for check pin mounting, RSA terminal and RSB terminal are shorted with wiring.
- ③ Mounting of 0 Ω resistor (short resistor)  
To commonize RSS, by utilizing the rounds for C\_OAM, C\_OAP and C\_OBM, C\_OBP, OUTA+ and OUTA-, OUTB- and OUTB+ are shorted with wiring etc.
- ④ Removal of resistor R\_RSB  
The resistor R\_RSA becomes RRS in the circuit diagram below. The constant current control value is set according to the input voltage Vref.
- ⑤ Set HBMODE to "H" level  
In order to input "H" level, please set a short pin to "H" side.

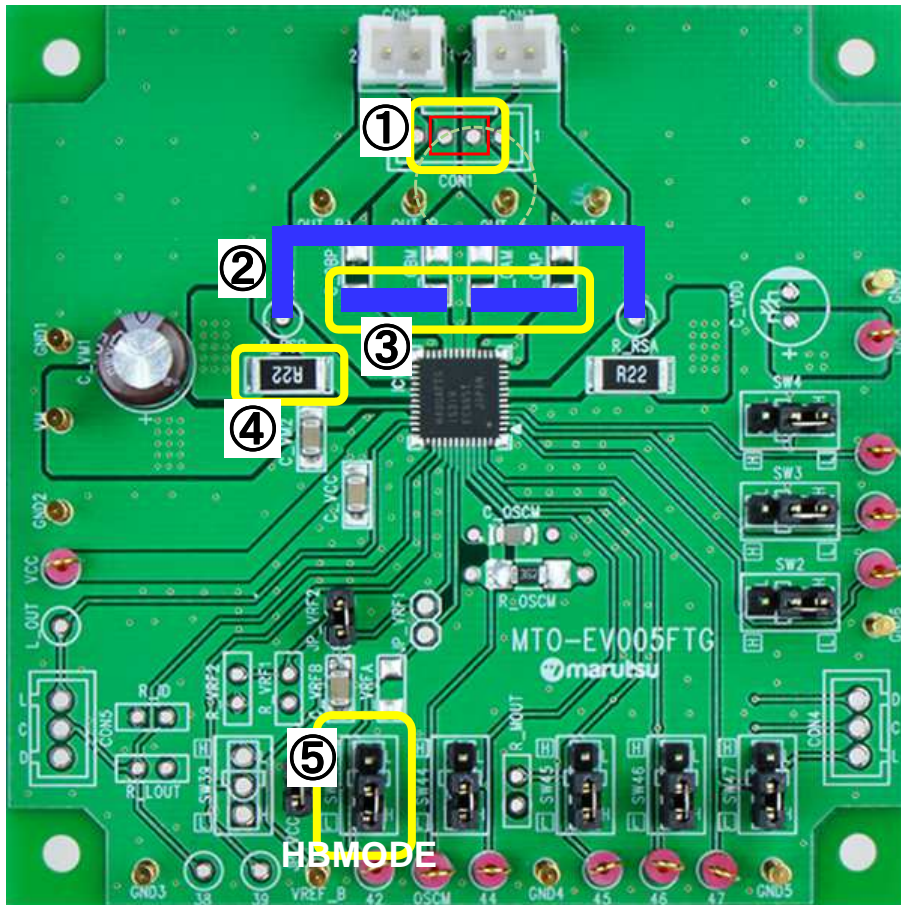

## 【Changed Function of Terminal】

In Large Mode, the functions of each terminal are changed as shown in the table on the right.

Silk name	Signal name
44	IN1
45	IN2
46	PWM
47	Non use
2	Non use
3	Non use

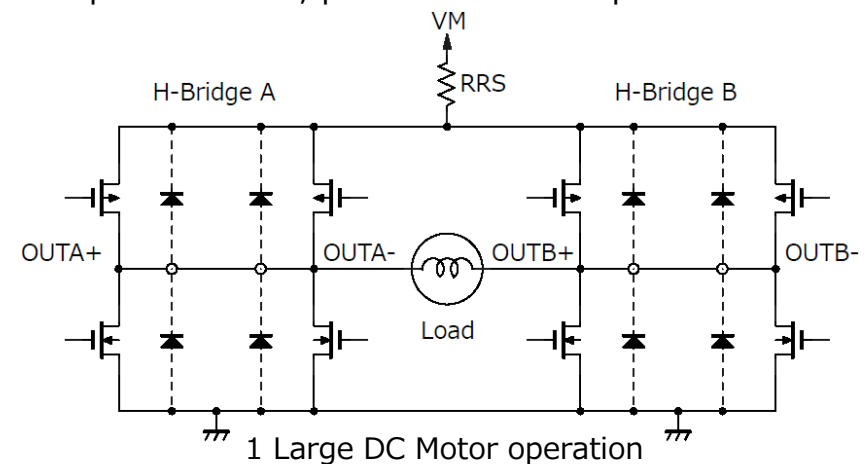

# Setting Evaluation Board :1

## Setting Motor Current

The TB67H400AFTG conducts motor operation by PWM constant current control which is based on the frequency of the OSCM oscillation circuit. The maximum current value (set Motor current value) can be determined by a sense resistor (RRS) and the reference voltage (Vref).

### Formula of setting Motor Current Value

$$I_{out(max)} = V_{ref}(\text{gain}) \times \frac{V_{ref}(V)}{R_{RS}(\Omega)}$$

Vref(gain): damping ratio of Vref is 1/5.0(typ.)

This board is set to RRS=0.22Ω

By using the jumper of JP\_VRF1, Vref of A and B channel are unified, and both can be set from the VrefA pin.

And it is also possible to generate a Vref voltage from the built-in regulator of VCC voltage by mounting resistors in R\_VRF 1 and R\_VRF2, and shorting JP\_VRF2 on this board.

However, please note that if more current than the built-in regulator's ability is drawn, VCC regulation may not be maintained. So that please be careful that total of voltage dividing resistors does not become less than 10kΩ.

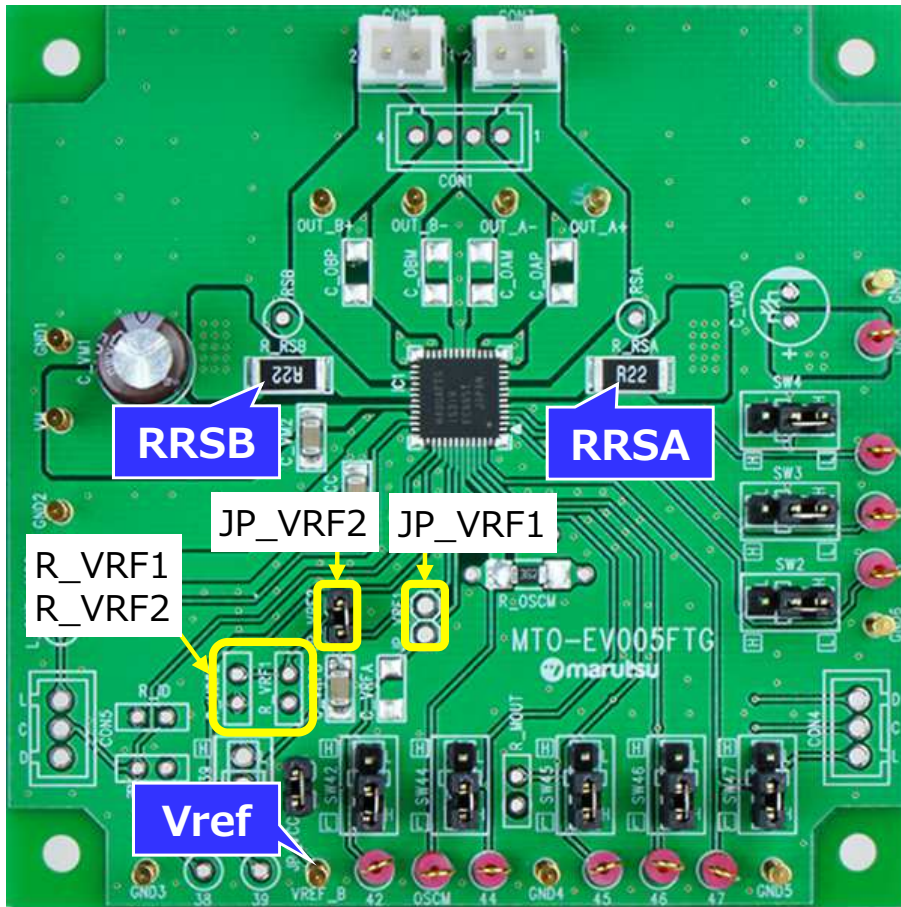

### Waveform of Motor Current

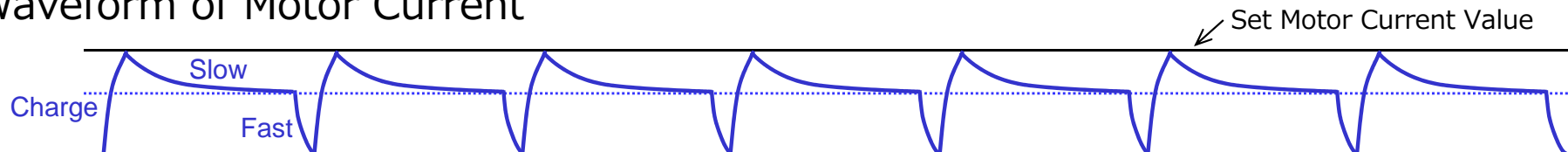

# Setting Evaluation Board :2

## Setting the Chopping Frequency for constant current PWM control

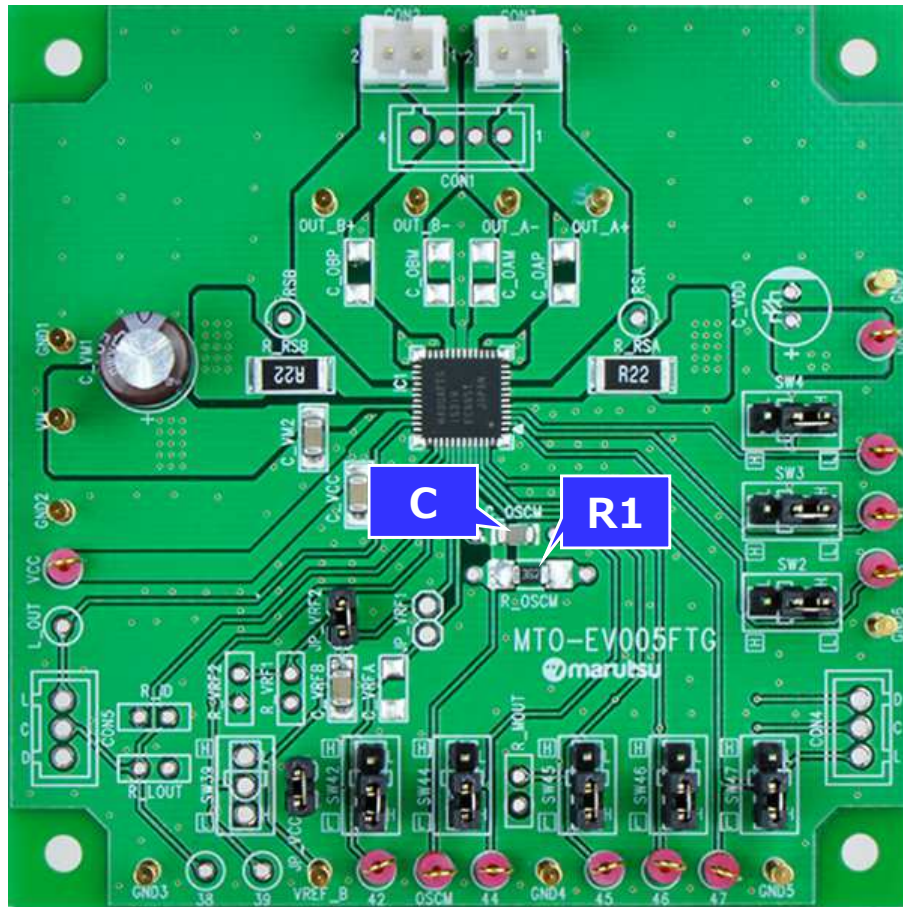

In PWM control of the TB67H400AFTG, the internal oscillation frequency ( $f_{OSCM}$ ) and the chopping frequency ( $f_{chop}$ ) can be adjusted according to the constant of the external components those are connected to the OSCM pin. In general,  $f_{chop}$  is recommended to set in the frequency range of 50kHz to 100kHz.

### Formula of Chopping Frequency

$$f_{OSCM} = 1 / [0.56 \times \{C \times (R1 + 500)\}]$$

$$f_{chop} = f_{OSCM} / 16$$

This board is set to 100kHz by mounting  $C=270\text{pF}$  and  $R1=3.6\text{k}\Omega$ .

### Waveform of Motor Current

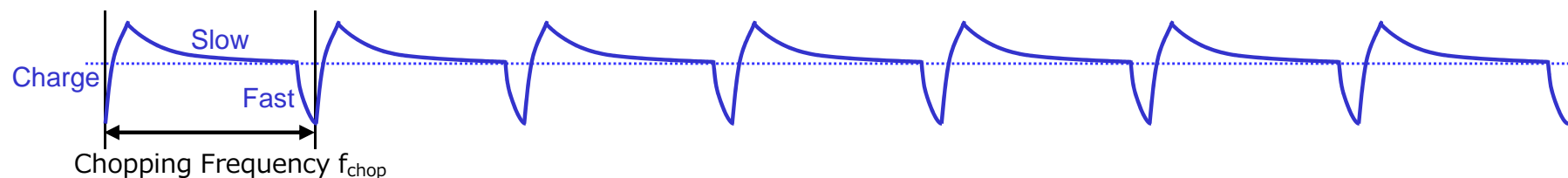



# Setting Evaluation Board :3 Setting for Motor Operation

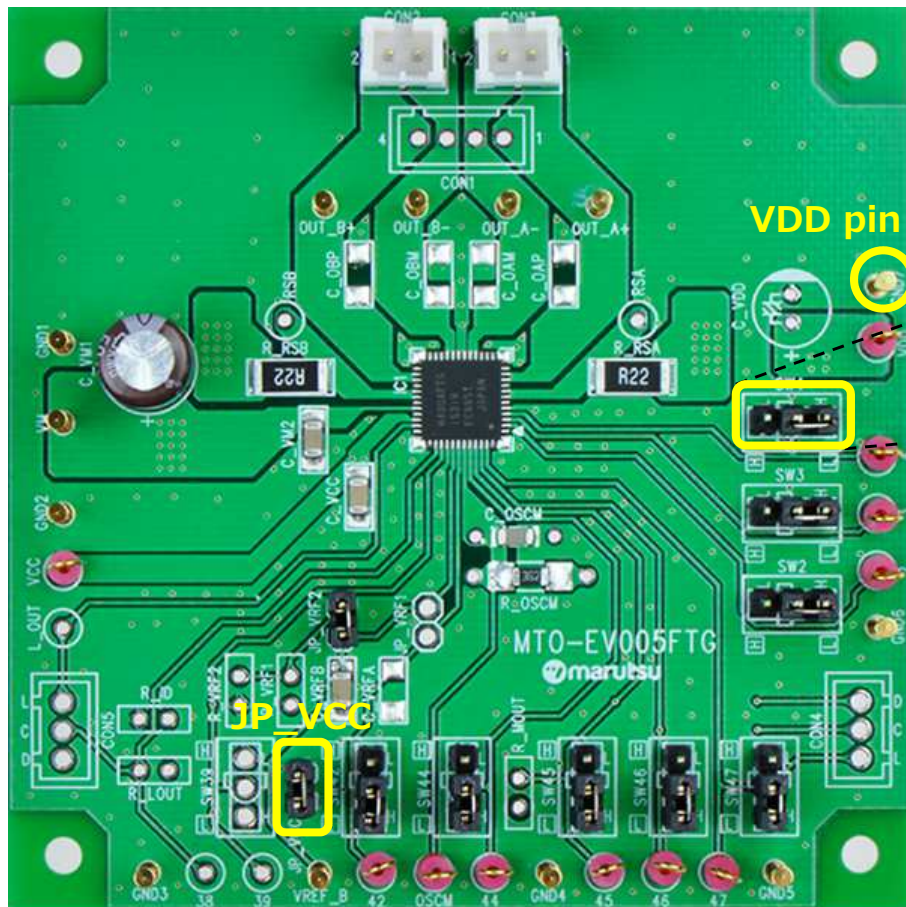

【Enlarged view of the jumper section】

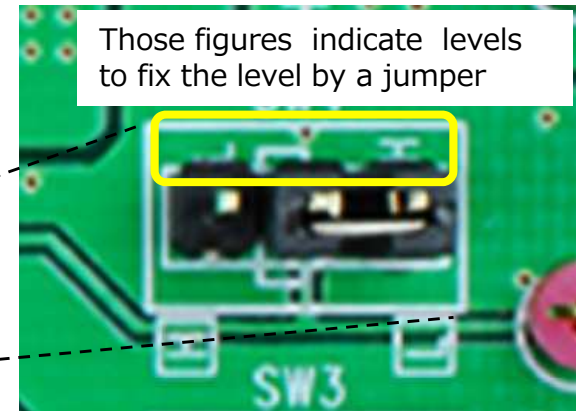

On this evaluation board, jumpers as shown in the picture above are provided for setting operation of TB67H400AFTG

When selecting functions by using jumpers, please short the JP\_VCC, or supply high level from the VDD pin.

The characters surrounded by white square frame close to the jumpers show the Level (H/L). Please change the position of jumpers in accordance with the function setting to be used.

Further when inputting signals from the outside, please remove the short pins.

# Setting Evaluation Board :4

## Setting for Motor Operation – Input/Output Function

INA1, INA2 (Small mode)

Input			Output		
PWMA	INA1	INA2	OUTA+	OUTA-	Mode
L	L	L	OFF (High Impedance)	OFF (High Impedance)	※Standby
H					STOP (OFF)
L	L	H	L	L	Short Break
H					Reverse
L	H	L	L	L	Short Break
H					Forward
L	H	H	L	L	Short Break
H					Short Break

INB1, INB2 (Small mode)

Input			Output		
PWMA	INB1	INB2	OUTB+	OUTB-	Mode
L	L	L	OFF (High Impedance)	OFF (High Impedance)	※Standby
H					STOP (OFF)
L	L	H	L	L	Short Break
H					Reverse
L	H	L	L	L	Short Break
H					Forward
L	H	H	L	L	Short Break
H					Short Break

INA1, INA2 (Large mode)

Input			Output		
PWMA	INA1	INA2	OUT+	OUT-	Mode
L	L	L	OFF (High Impedance)	OFF (High Impedance)	※Standby
H					STOP (OFF)
L	L	H	L	L	Short Break
H					Reverse
L	H	L	L	L	Short Break
H					Forward
L	H	H	L	L	Short Break
H					Short Break

In case of Large mode

Operations are controlled by the A channel terminals (INA1, INA2, PWMA). All signal input to the B channel terminals (INB1, INB2, PWMB) are invalid.

In use of Large mode, it is recommended to set all INB1, INB2 and PWMB to Low.

※ Standby mode is entered when all 6 terminals, INA1, INA2, PWMA, INB1, INB2, and PWMB are set to Low

# Circuit of Evaluation Board

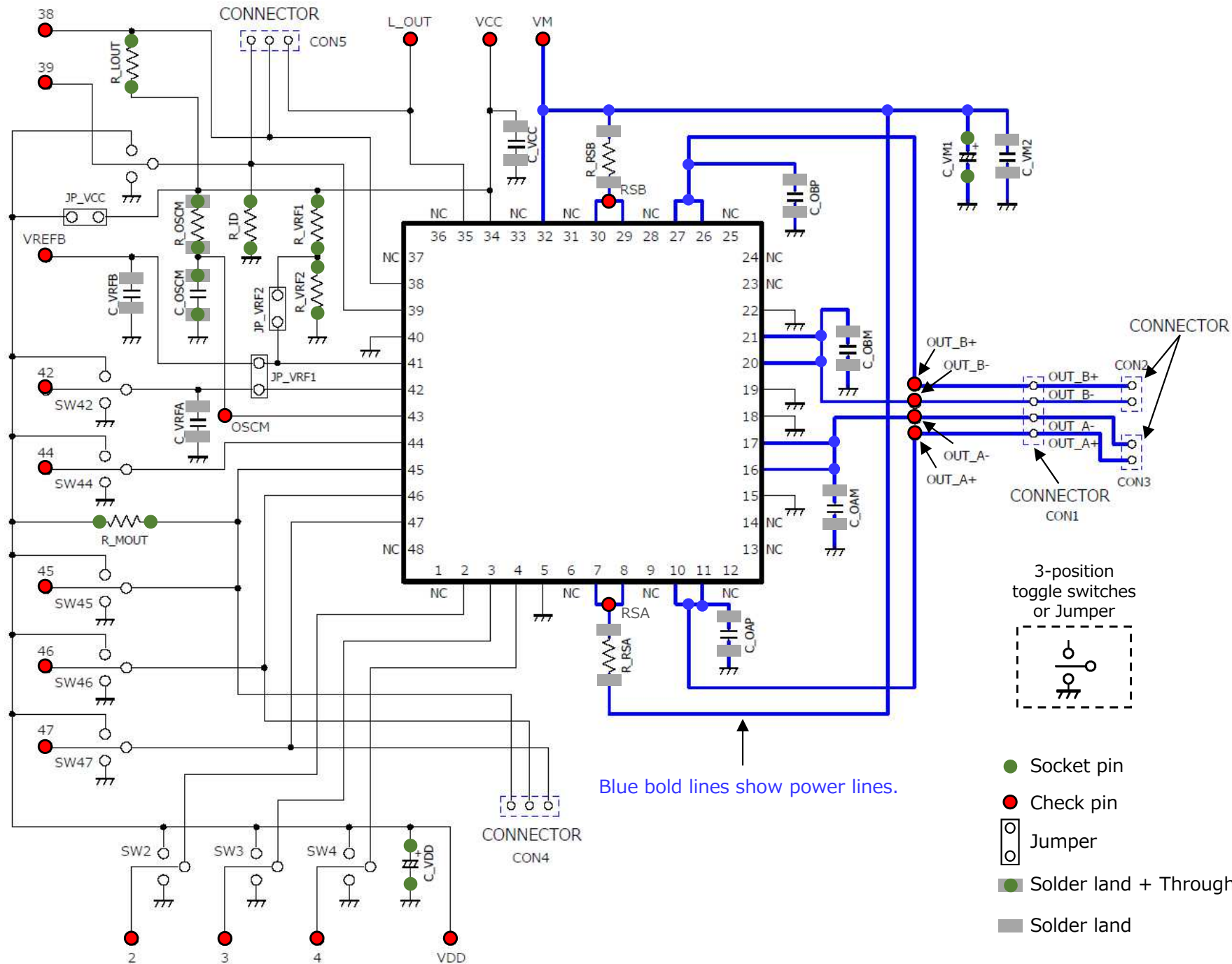

- Socket pin
- Check pin
- Jumper
- Solder land + Through hole
- Solder land