

MPS 7S/03-5/04 S TN B B

Weidmüller Interface GmbH & Co. KG

Klingenbergstraße 26

D-32758 Detmold

Germany

www.weidmueller.com

Product image

SNAP IN

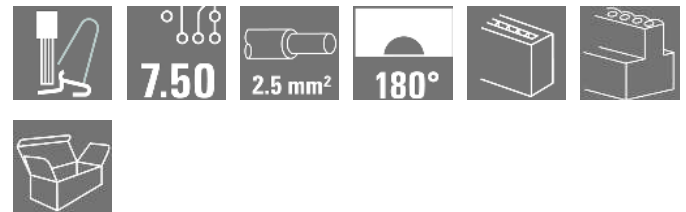

OMNIMATE® 4.0 - the next evolution step

OMNIMATE® 4.0 follows the trend of One Cable Technology (OCT). The modular concept enables the fast configuration of hybrid interfaces, which transmit data, signals and energy in a single connector. As a result, you can reduce the cabling effort in a wide variety of applications, simplify maintenance and accelerate automation processes. The unique SNAP IN connection is the backbone and speeds up the wiring process.

The fastest connection yet

- Fast, safe, and tool-free wiring due to unique SNAP IN connection
- Ready for Robot through "wire ready" delivery with open clamping point
- Optical and acoustic feedback indicates proper wiring

Create your own configuration

- Flexible configuration and ordering via the Weidmüller Configurator (WMC)
- Dispatch within three days – even for individually configured products
- Automatic offer preparation for the configured product

Simply configuration of modular hybrid connectors

- Flexible combination options for power, signal and data transmission
- Future-proof Single-Pair Ethernet technology

General ordering data

Version	PCB plug-in connector, female plug, Pitch in mm (P): 7.50 mm, Number of poles: 7, Box
Order No.	8000078351
Type	MPS 7S/03-5/04 S TN B B
GTIN (EAN)	4064675621942
Qty.	42 pc(s).
Product data	IEC: 1000 V / 34.6 A / 0.5 - 4 mm ² UL: / 18.5 A / AWG 20 - AWG 12
Packaging	Box

Creation date August 24, 2023 9:16:43 AM CEST

MPS 7S/03-5/04 S TN B B**Weidmüller Interface GmbH & Co. KG**

Klingenbergstraße 26

D-32758 Detmold

Germany

www.weidmueller.com

Technical data**Dimensions and weights**

Depth	34.95 mm	Depth (inches)	1.376 inch
Height	15.5 mm	Height (inches)	0.61 inch
Net weight	3.457 g		

Temperatures

Operating temperature, min.	-50 °C	Operating temperature, max.	125 °C
-----------------------------	--------	-----------------------------	--------

System Parameters

Product family	OMNIMATE 4.0		
Type of connection	Field connection		
Wire connection method	SNAP IN		
Pitch in mm (P)	7.5 mm		
Conductor outlet direction	180°		
Number of poles	7		
L1 in mm	15 mm		
L1 in inches	0.591 inch		
L2 in mm	15 mm		
L2 in inch	0.591 inch		
Number of rows	1		
Pin series quantity	1		
Rated cross-section	2.5 mm ²		
Touch-safe protection acc. to DIN VDE 57 106	Safe from finger touch		
Touch-safe protection acc. to DIN VDE 0470	IP 20		
Stripping length	9 mm		
Stripping length tolerance	min.	8 mm	
	max.	10 mm	
Plugging cycles	≥ 25		
Plugging force/pole, max.	9 N		
Pulling force/pole, max.	8 N		

Material data

Insulating material	PBT GF	Colour	black
Colour chart (similar)	RAL 9011	Insulating material group	I
Comparative Tracking Index (CTI)	≥ 600	UL 94 flammability rating	V-0
Contact material	CuSn	Contact surface	tinned
Storage temperature, min.	-25 °C	Storage temperature, max.	55 °C
Operating temperature, min.	-50 °C	Operating temperature, max.	125 °C

Conductors suitable for connection

Clamping range, min.	0.34 mm ²
Clamping range, max.	4 mm ²
Wire connection cross section AWG, min.	AWG 20
Wire connection cross section AWG, max.	AWG 12
Solid, min. H05(07) V-U	0.5 mm ²
Solid, max. H05(07) V-U	2.5 mm ²
Flexible, min. H05(07) V-K	0.5 mm ²
Flexible, max. H05(07) V-K	4 mm ²

Creation date August 24, 2023 9:16:43 AM CEST

MPS 7S/03-5/04 S TN B B

Weidmüller Interface GmbH & Co. KG
 Klingenbergstraße 26
 D-32758 Detmold
 Germany

www.weidmueller.com

Technical data

w. plastic collar ferrule, DIN 46228 pt 4, 0.34 mm²
 min.

w. plastic collar ferrule, DIN 46228 pt 4, 2.5 mm²
 max.

w. wire end ferrule, DIN 46228 pt 1, 0.34 mm²
 min.

w. wire end ferrule, DIN 46228 pt 1, 2.5 mm²
 max.

Outer diameter of insulation, max. 4 mm

Clampable conductor	Cross-section for conductor connection	nominal	0.34 mm ²
	wire end ferrule	Stripping length	nominal 10 mm
		Recommended wire-end ferrule	H0.34/12 TK
	Cross-section for conductor connection	nominal	0.5 mm ²
	wire end ferrule	Stripping length	nominal 12 mm
		Recommended wire-end ferrule	H0.5/16 OR
		Stripping length	nominal 10 mm
		Recommended wire-end ferrule	H0.5/10
	Cross-section for conductor connection	nominal	0.75 mm ²
	wire end ferrule	Stripping length	nominal 12 mm
		Recommended wire-end ferrule	H0.75/16 W
		Stripping length	nominal 10 mm
		Recommended wire-end ferrule	H0.75/10
	Cross-section for conductor connection	nominal	1 mm ²
	wire end ferrule	Stripping length	nominal 12 mm
		Recommended wire-end ferrule	H1.0/16 GE
		Stripping length	nominal 10 mm
		Recommended wire-end ferrule	H1.0/10
	Cross-section for conductor connection	nominal	1.5 mm ²
	wire end ferrule	Stripping length	nominal 12 mm
	Recommended wire-end ferrule	H1.5/16 R	
	Stripping length	nominal 10 mm	
	Recommended wire-end ferrule	H1.5/10	
Cross-section for conductor connection	nominal	2.5 mm ²	
wire end ferrule	Stripping length	nominal 10 mm	
	Recommended wire-end ferrule	H2.5/15D BL	
	Stripping length	nominal 10 mm	
	Recommended wire-end ferrule	H2.5/10	

Reference text The outside diameter of the plastic collar should not be larger than the pitch (P)

MPS 7S/03-5/04 S TN B B

Weidmüller Interface GmbH & Co. KG

Klingenbergstraße 26

D-32758 Detmold

Germany

www.weidmueller.com

Technical data

Rated data acc. to IEC

tested acc. to standard	IEC 60664-1, IEC 61984	Rated current, min. number of poles (Tu=20°C)	34.6 A
Rated current, max. number of poles (Tu=20°C)	29.1 A	Rated current, min. number of poles (Tu=40°C)	30.7 A
Rated current, max. number of poles (Tu=40°C)	25.9 A	Rated voltage for surge voltage class / pollution degree II/2	1,000 V
Rated voltage for surge voltage class / pollution degree III/2	1,000 V	Rated impulse voltage for surge voltage class/ pollution degree II/2	6 kV
Rated impulse voltage for surge voltage class/ pollution degree III/2	8 kV		

Rated data acc. to UL 1059

Institute (cURus)



Certificate No. (cURus)

Rated voltage (Use group F / UL 1059)	1,000 V	Rated current (Use group B / UL 1059)	18.5 A
Rated current (Use group C / UL 1059)	18.5 A	Rated current (Use group D / UL 1059)	10 A
Rated current (Use group F / UL 1059)	18.5 A	Wire cross-section, AWG, min.	AWG 20
Wire cross-section, AWG, max.	AWG 12	Reference to approval values	Specifications are maximum values, details - see approval certificate.

Technical data - hybrid (power)

Number of poles (Power)	3	Number of rows (Power)	1
Pitch in mm (Power)	7.5 mm	Pitch in inches (Power)	0.295 inch
Contact material (Power)	CuSn	Contact surface (Power)	tinned
Clamping range, min. (Power)	0.5 mm ²	Clamping range, max. (Power)	4 mm ²
w. wire end ferrule, DIN 46228 pt 1, min. (Power)	0.5 mm ²	w. wire end ferrule, DIN 46228 pt 1, max. (Power)	2.5 mm ²
Wire cross-section, AWG, min. (Power)	AWG 20	Wire cross-section, AWG, max. (Power)	AWG 12
w. plastic collar ferrule, DIN 46228 pt 4, min. (Power)	2.5 mm ²	w. plastic collar ferrule, DIN 46228 pt 4, max. (Power)	0.5 mm ²
Flexible, min. H05(07) V-K (Power)	0.5 mm ²	Flexible, max. H05(07) V-K (Power)	4 mm ²
Solid, min. H05(07) V-U (Power)	0.5 mm ²	Solid, max. H05(07) V-U (Power)	2.5 mm ²
Outside diameter of the insulation, max. (Power)	4 mm	Stripping length (Power)	9 mm
Rated current (Use group B / UL 1059) (Power)	18.5 A	Rated current (Use group C / UL 1059) (Power)	18.5 A
Rated current (Use group D / UL 1059) (Power)	10 A	Rated current, min. number of poles (Tu=20°C) (Power)	34.6 A
Rated current, max. number of poles (Tu=20°C) (Power)	29.1 A	Rated current, min. number of poles (Tu=40°C) (Power)	30.7 A
Rated current, max. number of poles (Tu=40°C) (Power)	25.9 A	Rated impulse voltage for surge voltage class/ pollution degree II/2 (Power)	4 kV
Rated impulse voltage for surge voltage class/ pollution degree III/2 (Power)	4 kV	Rated voltage (Use group B / UL 1059) (Power)	600 V
Rated voltage (Use group C / UL 1059) (Power)	600 V	Rated voltage (Use group D / UL 1059) (Power)	600 V
Rated voltage for surge voltage class / pollution degree II/2 (Power)	1,000 V	Rated voltage for surge voltage class / pollution degree III/2 (Power)	1,000 V
Rated voltage for surge voltage class / pollution degree III/3 (Power)	630 V	Clearance distance, min. (Power)	9.96 mm

Creation date August 24, 2023 9:16:43 AM CEST

Catalogue status 18.08.2023 / We reserve the right to make technical changes.

4

MPS 7S/03-5/04 S TN B B

Weidmüller Interface GmbH & Co. KG

Klingenbergstraße 26

D-32758 Detmold

Germany

www.weidmueller.com

Technical data

Technical data - hybrid (signal)

Number of poles (Signal)	4	Pitch in mm (Signal)	5 mm
Pitch in inches (Signal)	0.197 inch	Contact material (Signal)	CuSn
Contact surface (Signal)	tinned	Clamping range, min. (Signal)	0.5 mm ²
Clamping range, max. (Signal)	4 mm ²	Wire cross-section, AWG, min. (Signal)	AWG 20
Wire cross-section, AWG, max. (Signal)	AWG 12	w. plastic collar ferrule, DIN 46228 pt 4, min. (Signal)	0.5 mm ²
w. plastic collar ferrule, DIN 46228 pt 4, max. (Signal)	2.5 mm ²	w. wire end ferrule, DIN 46228 pt 1, min. (Signal)	0.5 mm ²
w. wire end ferrule, DIN 46228 pt 1, max. (Signal)	2.5 mm ²	Flexible, min. H05(07) V-K (Signal)	0.5 mm ²
Flexible, max. H05(07) V-K (Signal)	4 mm ²	Solid, min. H05(07) V-U (Signal)	0.5 mm ²
Solid, max. H05(07) V-U (Signal)	2.5 mm ²	Outside diameter of the insulation, max. (Signal)	4 mm
Stripping length (Signal)	9 mm	Rated current (Use group B / UL 1059) (Signal)	18.5 A
Rated current (Use group C / UL 1059) (Signal)	18.5 A	Rated current (Use group D / UL 1059) (Signal)	10 A
Rated current, min. number of poles (Tu=20°C) (Signal)	26.8 A	Rated current, max. number of poles (Tu=20°C) (Signal)	19.7 A
Rated current, min. number of poles (Tu=40°C) (Signal)	23.1 A	Rated current, max. number of poles (Tu=40°C) (Signal)	16.9 A
Rated impulse voltage for surge voltage class/ pollution degree II/2 (Signal)	4 kV	Rated impulse voltage for surge voltage class/ pollution degree III/2 (Signal)	4 kV
Rated impulse voltage for surge voltage class/ pollution degree III/3 (Signal)	4 kV	Rated voltage (Use group B / UL 1059) (Signal)	600 V
Rated voltage (Use group C / UL 1059) (Signal)	600 V	Rated voltage (Use group D / UL 1059) (Signal)	600 V
Rated voltage for surge voltage class / pollution degree II/2 (Signal)	400 V	Rated voltage for surge voltage class / pollution degree III/2 (Signal)	320 V
Rated voltage for surge voltage class / pollution degree III/3 (Signal)	250 V	Clearance distance, min. (Signal)	7.5 mm
Creepage distance, min. (Signal)	7.5 mm		

Classifications

ETIM 6.0	EC002638	ETIM 7.0	EC002638
ETIM 8.0	EC002638	ECLASS 9.0	27-44-03-09
ECLASS 9.1	27-44-03-09	ECLASS 10.0	27-44-03-09
ECLASS 11.0	27-46-02-02	ECLASS 12.0	27-46-03-02

Important note

IPC conformity	Conformity: The products are developed, manufactured and delivered according international recognized standards and norms and comply with the assured properties in the data sheet resp. fulfill decorative properties in accordance with IPC-A-610 "Class 2". Further claims on the products can be evaluated on request.
Notes	<ul style="list-style-type: none"> Rated current related to rated cross-section & min. No. of poles. P on drawing = pitch Rated data refer only to the component itself. Clearance and creepage distances to other components are to be designed in accordance with the relevant application standards. Wire end ferrule without plastic collar to DIN 46228/1 Long term storage of the product with average temperature of 50 °C and average humidity 70%, 36 months

Creation date August 24, 2023 9:16:43 AM CEST

Catalogue status 18.08.2023 / We reserve the right to make technical changes.

Data sheet**MPS 7S/03-5/04 S TN B B****Weidmüller Interface GmbH & Co. KG**
Klingenbergstraße 26
D-32758 Detmold
Germany

www.weidmueller.com

Technical data**Approvals**

Approvals



UL File Number Search	UL Website
Certificate No. (cURus)	E60693

Downloads

Approval/Certificate/Document of Conformity	Declaration of the Manufacturer
Engineering Data	CAD data – STEP
User Documentation	Assembly instructions MPS 5 EN DE
Catalogues	Catalogues in PDF-format

MPS 7S/03-5/04 S TN B B

Weidmüller Interface GmbH & Co. KG
 Klingenbergstraße 26
 D-32758 Detmold
 Germany

www.weidmueller.com

Drawings

Product image

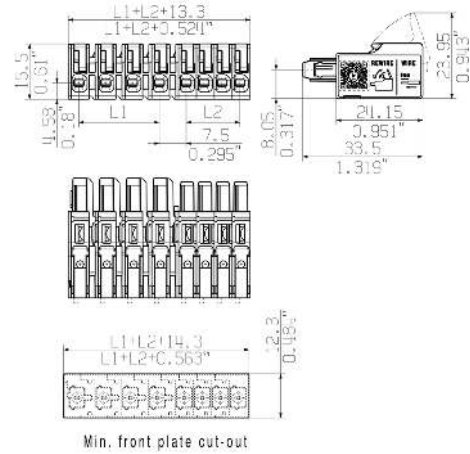

Product benefits



Fastest connection technology SNAP IN

Product benefits



Acoustic and visual feedback



Allgemeingültige Kundenzeichnung, aktueller Stand nur auf Anfrage
 General customer drawing, topical version only if required

Shown: MPS 7S/04-5/04 S

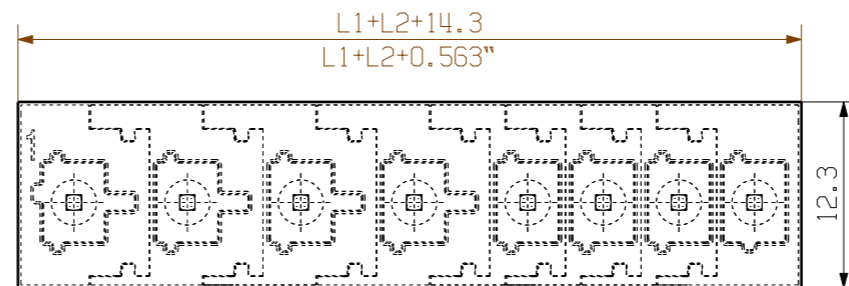
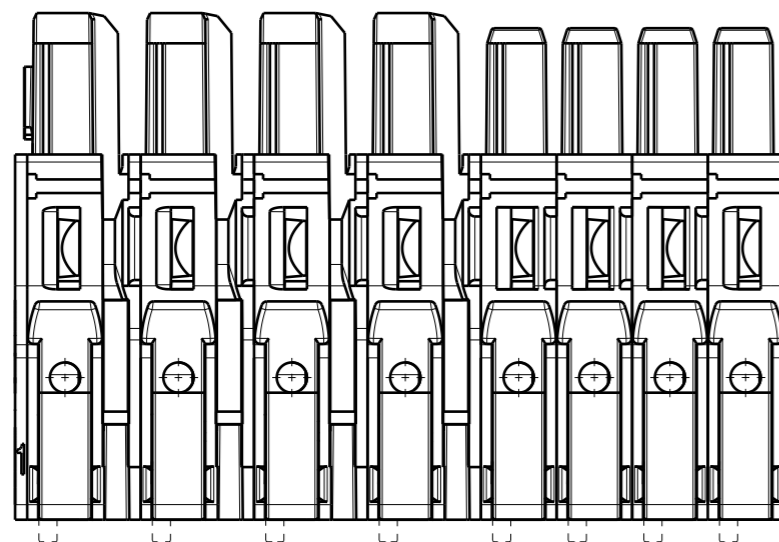
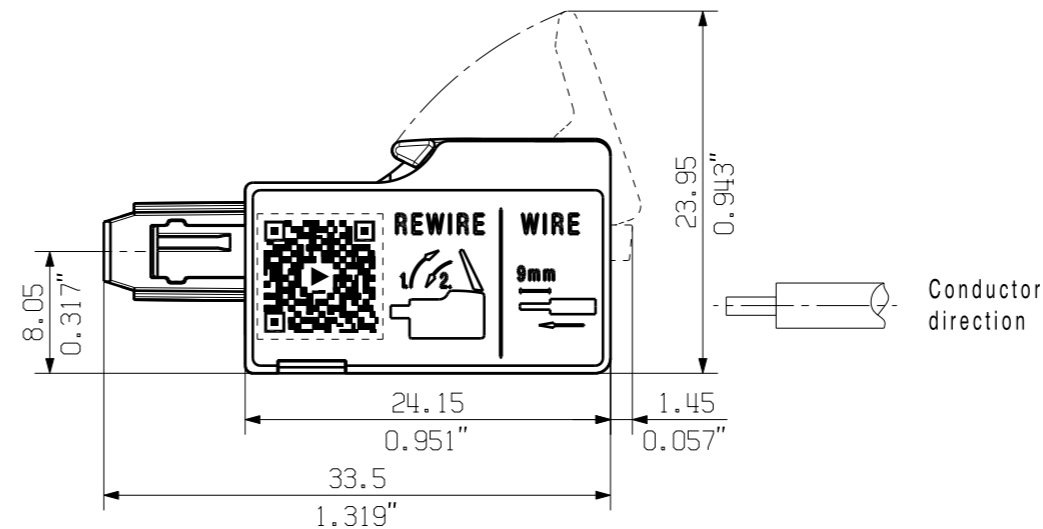
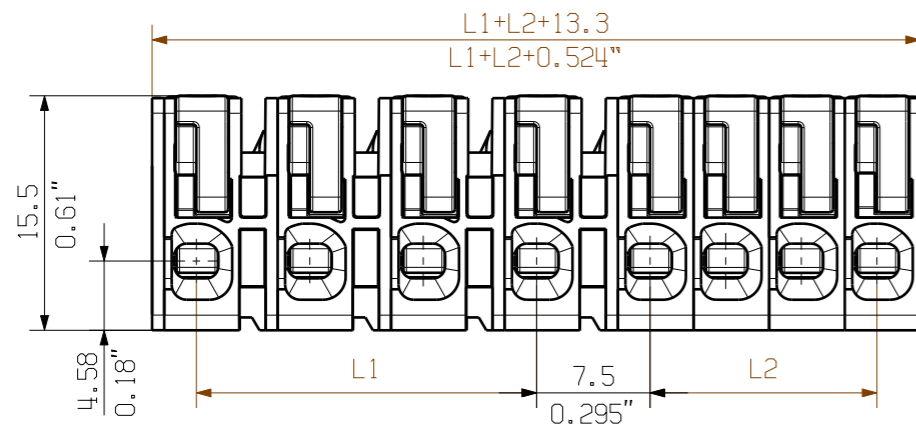

Min. front plate cut-out

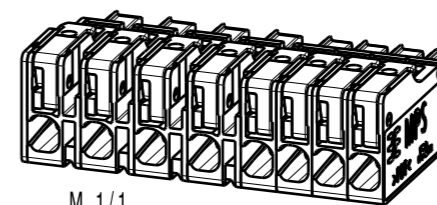

Further dim. & info. see data sheet

MPS 7S/01-5/09	1	.	.	9	40.00	1.575
MPS 7S/02-5/08	2	7.50	0.295	8	35.00	1.378
MPS 7S/01-5/08	1	.	.	8	35.00	1.378
MPS 7S/02-5/07	2	7.50	0.295	7	30.00	1.181
MPS 7S/01-5/07	1	.	.	7	30.00	1.181
MPS 7S/03-5/06	3	15.00	0.591	6	25.00	0.984
MPS 7S/02-5/06	2	7.50	0.295	6	25.00	0.984
MPS 7S/01-5/06	1	.	.	6	25.00	0.787
MPS 7S/04-5/05	4	22.50	0.886	5	20.00	0.787
MPS 7S/03-5/05	3	15.00	0.591	5	20.00	0.787
MPS 7S/02-5/05	2	7.50	0.295	5	20.00	0.787
MPS 7S/01-5/05	1	.	.	5	20.00	0.787
MPS 7S/04-5/04	4	22.50	0.886	4	15.00	0.591
MPS 7S/03-5/04	3	15.00	0.591	4	15.00	0.591
MPS 7S/02-5/04	2	7.50	0.295	4	15.00	0.591
MPS 7S/01-5/04	1	.	.	4	15.00	0.591
MPS 7S/05-5/03	5	30.00	1.181	3	10.00	0.394
MPS 7S/04-5/03	4	22.50	0.886	3	10.00	0.394
MPS 7S/03-5/03	3	15.00	0.591	3	10.00	0.394
MPS 7S/02-5/03	2	7.50	0.295	3	10.00	0.394
MPS 7S/01-5/03	1	.	.	3	10.00	0.394
MPS 7S/06-5/02	6	37.50	1.476	2	5.00	0.197
MPS 7S/05-5/02	5	30.00	1.181	2	5.00	0.197
MPS 7S/04-5/02	4	22.50	0.886	2	5.00	0.197
MPS 7S/03-5/02	3	15.00	0.591	2	5.00	0.197
MPS 7S/02-5/02	2	7.50	0.295	2	5.00	0.197
MPS 7S/01-5/02	1	.	.	2	5.00	0.197
Name	n Poles P=7.5	L1 [mm]	L1 [inch]	n Poles P=5	L2 [mm]	L2 [inch]

For the mounting of PCBs, it should be noted that the rated data given in the catalogue relates only to the connection elements. The necessary creepage and clearance paths must be observed in connection with the respective applicant in accordance to VDE 0110. The current-carrying capacity and pitch tolerance is to be determined according to DIN IEC 326 part 3 very fine.

Weidmüller connectors are tested to the DIN VDE 0627 standard, and are valid for its field of application. Provided that the connectors are used to the intended purpose, all requirements with respect to the occurring of electrical, mechanical, thermic and corrosive stress will be satisfied.

	First Issue Date	Max. nos.	Prim PLM Part No.:		Prim ERP Part No.:	
	19.04.2021	Modification				
	Scale: 2/1	Size: A3	74516 Drawing no. Issue no. 0			
	Drawings Assembly		Sheet 3 of 4 sheets MPS 7S/...-5/... S			
Date: 19.04.2021 Name: Tauber-Reglin, Responsible:		Date: 06.05.2021 Name: Sapina, Svetos Approved:		Product file:		